

CP660

SERVICE MANUAL

REVISION 0

Canon

FEB.1999

FY8-13FJ-000

IMPORTANT

THE INFORMATION CONTAINED HEREIN IS PUBLISHED BY CANON INC., JAPAN. SPECIFICATIONS AND OTHER INFORMATION CONTAINED HEREIN MAY VARY SLIGHTLY FROM ACTUAL MACHINE VALUES OR THOSE FOUND IN ADVERTISING AND OTHER PRINTED MATTER.

ANY QUESTIONS REGARDING INFORMATION CONTAINED HEREIN SHOULD BE DIRECTED TO THE COPIER SERVICE DEPARTMENT OF THE COMPANY.

COPYRIGHT © 1999 CANON INC.

***Printed in Japan
Imprimé au Japon***

Use of this manual should be strictly supervised to avoid disclosure of confidential information.

Prepared by

OFFICE IMAGING PRODUCTS TECHNICAL SUPPORT DEPARTMENT 3
OFFICE IMAGING PRODUCTS TECHNICAL SUPPORT DIVISION

CANON INC.

7-5-1, Hakusan, Toride-shi, Ibaraki 302-8501 Japan

INTRODUCTION

This Service Manual contains basic data and figures on the color printer needed to service the machine in the field.

This machine consists of the following system units:

1. Reader unit
2. Editor
3. Original holder
4. Printer unit
5. Duplexing unit
6. R cassette
7. PS/PCL board*

* Remains disabled when the printer unit is used in a copier mode.

For the reader unit, duplexing unit, R cassette, and PS/PCL board, refer to their respective Service Manuals. This manual covers the printer unit, duplexing unit, and R cassette, and consists of the following chapters:

Chapter 1 General Description introduces the machine's features and specifications, shows how to operate it, and explains how copies are made.

Chapter 2 Basic Operation provides outlines of the machine's various mechanical workings.

Chapter 3 Laser Exposure System discusses the principles of operation used for the mechanical/electrical operations of the machine's laser system. It also explains the timing at which the various units involved are operated, and shows how they may be disassembled/assembled and adjusted.

Chapter 4 Image Formation System discusses the principles of how images are formed. It also explains the timing at which the various units involved in image formation are operated, and shows how they may be disassembled/assembled and adjusted.

Chapter 5 Pick-Up/Feeding System discusses the principles of how the printer unit picks up and moves paper inside it. It also explains the timing at which the various units involved are operated, and shows how they may be disassembled/assembled and adjusted.

Chapter 6 Fixing System discusses the principles of how the printer unit fuses toner images to paper. It also explains the timing at which the various units involved are operated, and shows how they may be disassembled/assembled and adjusted.

Chapter 7 Externals/Auxiliary Mechanisms shows the machine's external parts, and explains the principles used for the machine's various control mechanisms in view of the functions of electrical and mechanical units and in relation to their timing of operation. It also shows how these units may be disassembled/assembled and adjusted.

Chapter 8 Installation introduces requirements for the site of installation, and shows how the printer unit may be installed using step-by-step instructions.

Chapter 9 Maintenance and Servicing provides tables of periodically replaced parts and consumables/durables and scheduled servicing charts.

Chapter 10 Troubleshooting provides tables of maintenance/inspection, standards/adjustments, and problem identification (image fault/malfunction).

Appendix contains a general timing chart and general circuit diagrams.

The following rules apply throughout this Service Manual:

1. Each chapter contains sections explaining the purpose of specific functions and the relationship between electrical and mechanical systems with reference to the timing of operation.

In the diagrams,  represents the path of mechanical drive-where a signal name accompanies the symbol →, the arrow indicates the direction of the electric signal.

In the digital circuits, '1' is used to indicate that the voltage level of a given signal is "High," while '0' is used to indicate "Low." (The voltage value, however, differs from circuit to circuit.) In addition, the asterisk (*) as in "DRMD*" indicates that the DRMD signal goes on when '0'.

The expression "turn on the power" means flipping on the power switch, closing the front door, and closing the delivery unit door, which results in supplying the machine with power.

2. In practically all cases, the internal mechanisms of a microprocessor cannot be checked in the field. Therefore, the operations of the microprocessors used in the machines are not discussed: they are explained in terms of from sensors to the input of the DC controller PCB and from the output of the DC controller PCB to the loads.

The descriptions in this Service Manual are subject to change without notice for product improvement or other purposes, and major changes will be communicated in the form of Service Information bulletins.

All service persons are expected to have a good understanding of the contents of this Service Manual and all relevant Service Information bulletins and be able to identify and isolate faults in the machine.

Reference:

Reader Unit Service Manual:

FY8-13FH-000

PS/PCL Board Service Manual:

FY8-13FK-000

System Configuration

This printer unit is designed to accommodate the following accessories:

- Upper 500 Sheet Cassette CS-82 A4R/A5R/B5R/LTRR*1
- Duplex Unit-A1 *1
- 1000-Sheet Paper Deck-D1 *2,3
- 2x500-Sheet Paper Deck-C1 *2,3
- 2000-Sheet Paper Deck-N1 *2,3
- ACC Controller-A1 *2,3
- ACC Interface Board-B1 *3
- ACC Interface Unit-B1 *3
(ACC controller-A1, ACC Interface Board-B1 and Plate)
- Sorter-H1 (requires the Attachment Kit for STR-H1 if the printer unit is mounted to a Rack-A1) *2, *3
- Network Color PS/PCL Board-A1 *2
- Token Ring Board TB83

*1: Covered in this Service Manual

*2: Covered in a separate Service Manual.

*3:

If the printer unit is installed as a copier,

- Requires the ACC Interface Unit-B1,
- Requires the ACC Controller-A1.

If the printer unit is installed as a copier and a printer,

- Requires the ACC Controller-A1 and the ACC Interface Board-B1.

CONTENTS

CHAPTER 1 GENERAL DESCRIPTION

I. FEATURES	1-1	VIII. IMAGE FORMATION	1-20
II. SPECIFICATIONS.....	1-2	A. Outline.....	1-20
A. Printer Unit.....	1-2	B. Latent Static Image Formation Block	1-22
III. SAFETY OF LASER LIGHT.....	1-6	C. Development Block	1-25
IV. NAMES OF PARTS.....	1-7	D. Transfer Block	1-27
A. External View	1-7	E. ITD (intermediate transfer drum) Cleaning Block	1-31
B. Cross Section.....	1-11	F. Photosensitive Drum Cleaning.....	1-33
V. USING THE CONTROL PANEL.....	1-13	G. Fixing Block.....	1-34
VI. NOTES TO THE USER	1-15		
VII. NOTES TO THE SERVICE PERSON	1-16		
A. Storing the Drum Cartridge and the Toner Cartridges	1-16		
B. Points to Note When Handling the Drum Cartridge and the Toner Cartridges	1-18		

CHAPTER 2 BASIC OPERATION

I. BASIC OPERATIONS	2-1	D. Basic Sequence of Operations (used as a printer).....	2-14
A. Functional Construction	2-1	E. Controlling the Main Motor.....	2-19
B. Electrical Circuitry	2-2		
C. Inputs to and Outputs of the Major PCBs.....	2-3		

CHAPTER 3 LASER EXPOSURE SYSTEM

I. OUTLINE.....	3-1	III. LASER SCANNER MOTOR.....	3-9
II. LASER CONTROL CIRCUIT	3-3	A. Controlling the Laser Scanner Motor.....	3-9
A. Outline.....	3-3	IV. FAULT IN THE LASER SCANNER	3-11
B. Image Signal Processing	3-5	V. DISASSEMBLY/ASSEMBLY	3-12
C. Controlling the Laser Intensity	3-6	A. Printer Unit External Covers	3-13
D. Horizontal Sync Control	3-7	B. Door Switch Actuator	3-22
E. Controlling the Laser Diode Emission	3-8	C. Laser/Scanner Assembly	3-25

CHAPTER 4 IMAGE FORMATION SYSTEM

I.	OUTLINE.....	4-1	V.	IMAGE STABILIZATION CORRECTION CONTROL.....	4-21
	A. Construction.....	4-1		A. Environmental Changes Correction Control	4-21
	B. Operations.....	4-2		B. Image Density Correction Control (maximum density control).....	4-21
II.	FORMING LATENT STATIC IMAGES.....	4-5		C. Image Gradation Correction Control (requires a PS/PCL Board).....	4-22
	A. Outline.....	4-5		D. Detecting the Density.....	4-23
	B. Drum Cartridge Memory.....	4-6	VI.	HIGH-VOLTAGE POWER SUPPLY CIRCUIT.....	4-24
	C. Checking the Life of the Photosensitive Drum	4-8		A. Outline.....	4-24
	D. Monitoring the Waste Toner Case.....	4-9		B. High-Voltage PCB 1	4-26
III.	DEVELOPMENT	4-10		C. High-Voltage PCB 2.....	4-30
	A. Outline.....	4-10		D. Separation Static Eliminating Bias PCB.....	4-33
	B. Controlling the Developing Rotary	4-12	VII.	OTHER CONTROL MECHANISMS.....	4-34
	C. Locking the Developing Rotary	4-14		A. Developing Rotary Motor Control	4-34
	D. Detecting the Absence of the Toner Cartridges	4-14		B. Controlling the Cartridge Motor	4-36
	E. Detecting the Level of Color Toner...4-16			C. Controlling the Drum Motor.....	4-37
	F. Checking the Presence/Absence of a Color Toner Cartridge.....	4-17	VIII.	DISASSEMBLY/ASSEMBLY	4-38
	G. Checking the Level of Black Toner and the Presence/Absence of the Black Toner Cartridge	4-17		A. Drive System.....	4-39
IV.	TRANSFER.....	4-18		B. Charging, Developing, and Cleaning.....	4-45
	A. Outline.....	4-18		C. PCBs.....	4-53
	B. Locking the Secondary Transfer Belt.....	4-19			
	C. Controlling the ITD Cleaning Roller.....	4-20			

CHAPTER 5 PICK-UP/FEEDING SYSTEM

I.	OUTLINE.....	5-1	A.	Detecting Jams in the Printer Unit...5-29	
	A. Outline.....	5-1	B.	Detecting Jams in the Duplexing Unit.....	5-32
II.	PICK-UP ASSEMBLY.....	5-3	VI.	DISASSEMBLY/ASSEMBLY	5-34
	A. Pick-Up from the Cassette	5-3		A. Pick-Up Assembly	5-35
	B. Pick-Up from the Multifooter Tray....5-16			B. Delivery Assembly	5-39
	C. Controlling the Pick-Up Motor.....	5-19		C. Feeding Assembly.....	5-40
III.	FEEDING/DELIVERY ASSEMBLY	5-21		D. Registration Roller Assembly.....	5-40
	A. Outline.....	5-21		E. Multifooter Pick-Up Assembly	5-42
IV.	DUPLEXING UNIT	5-22		F. Multifooter Tray Pick-Up Roller.....	5-44
	A. Outline.....	5-22		G. Multifooter Tray Separation Pad	5-45
	B. Reversing Operation	5-25		H. Cassette Pick-UP, Feeding, and Separation Rollers	5-45
	C. Horizontal Registration Adjustment	5-26		I. PCBs.....	5-46
	D. Re-Pickup.....	5-28			
V.	DETECTING JAMS.....	5-29			

CHAPTER 6 FIXING SYSTEM

- I. OUTLINE.....6-1
- II. FIXING CONTROL CIRCUIT6-2
 - A. Controlling the Fixing Temperature6-2
 - B. Preventing Rush Current6-3
 - C. Protecting the Fixing Assembly6-4
- III. DISASSEMBLY/ASSEMBLY6-9
 - A. Fixing Assembly6-10
 - D. Detecting a Fault in the Fixing Assembly.....6-4

CHAPTER 7 EXTERNALS/AUXILIARY MECHANISMS

- I. CONTROL PANEL7-1
 - A. Outline.....7-1
 - B. Operations.....7-1
- II. FANS7-2
- III. POWER SUPPLY7-4
 - A. Power Supply7-4
 - B. Remote Switch.....7-6
 - C. Protective Mechanisms7-7
 - D. Power Save Mode7-8
- IV. DISASSEMBLY/ASSEMBLY7-9
 - A. Fans7-10
 - B. Power Supply Assembly7-13

CHAPTER 8 INSTALLATION

- I. SELECTING THE SITE.....8-1
- II. UNPACKING AND INSTALLATION.....8-3
 - A. Unpacking the Printer Unit.....8-3
 - B. Installing the Printer Unit.....8-4
 - C. Making Settings and Checking Images and Operations8-11
- III. RELOCATING THE MACHINE.....8-16
- IV. INSTALLING THE DUPLEXING UNIT ...8-17
- V. INSTALLING THE VERTICAL FEED CASSETTE (A4R, LTRR, B5R, A5R)8-20
- D. Selecting the Type of Message for the Printer Unit.....8-14

CHAPTER 9 MAINTENANCE AND SERVICING

- I. PERIODICALLY REPLACED PARTS.....9-1
- II. CONSUMABLES AND DURABLES9-1
- III. BASIC SERVICING CHART9-2

CHAPTER 10 TROUBLESHOOTING

I.	STANDARDS AND ADJUSTMENTS	10-1	B.	Thermistors, Lamps, and Heaters .	10-72
A.	Electrical System	10-1	C.	Clutches and Solenoids	10-74
II.	TROUBLESHOOTING IMAGE		D.	Fans and Motors	10-75
FAULTS	10-10		E.	PCBs	10-76
A.	Making Initial Checks	10-10	F.	Duplexing Unit	10-78
B.	Guide to Test Prints for the Printer		G.	Variable Resistors (VR), Light-Emitting	
Unit	10-12		Diodes, and Check Pins PCB	10-79	
C.	Troubleshooting Image Faults	10-14	VI.	SERVICE MODE	10-83
III.	TROUBLESHOOTING		A.	Entering the Service Mode	10-83
MALFUNCTIONS	10-28		B.	Menu Structure and Key	
A.	Error Codes	10-29	Assignment	10-83	
B.	Faults Not Identified by Error		C.	Main Menu	10-85
Codes	10-45		VII.	TEST PAGE PRINT MODE	10-93
IV.	TROUBLESHOOTING FEEDING		A.	Generating the Test Page	10-93
PROBLEMS	10-58		B.	Test Pattern	10-93
A.	Paper Jams	10-58	VIII.	SELF DIAGNOSIS	10-99
B.	Faulty Feeding	10-66	A.	Printer unit	10-99
V.	ARRANGEMENT AND FUNCTIONS OF				
ELECTRICAL PARTS	10-69				
A.	Sensors	10-70			

APPENDIX

A.	GENERAL TIMING CHART	A-1	D.	SPECIAL TOOLS	A-17
B.	SIGNALS AND ABBREVIATIONS	A-7	E.	SOLVENTS AND OILS	A-18
C.	GENERAL CIRCUIT DIAGRAM	A-15			

CHAPTER 1

GENERAL DESCRIPTION

This chapter provides specifications of the machine, instructions on how to operate the machine, and an outline of reproduction process.

I. FEATURES	1-1	VIII. IMAGE FORMATION	1-20
II. SPECIFICATIONS.....	1-2	A. Outline.....	1-20
A. Printer Unit.....	1-2	B. Latent Static Image Formation Block	1-22
III. SAFETY OF LASER LIGHT.....	1-6	C. Development Block	1-25
IV. NAMES OF PARTS.....	1-7	D. Transfer Block	1-27
A. External View	1-7	E. ITD (intermediate transfer drum) Cleaning Block	1-31
B. Cross Section.....	1-11	F. Photosensitive Drum Cleaning.....	1-33
V. USING THE CONTROL PANEL.....	1-13	G. Fixing Block.....	1-34
VI. NOTES TO THE USER	1-15		
VII. NOTES TO THE SERVICE PERSON	1-16		
A. Storing the Drum Cartridge and the Toner Cartridges	1-16		
B. Points to Note When Handling the Drum Cartridge and the Toner Cartridges	1-18		

I. FEATURES

1. Oil-Free Fixing Assembly

The fixing assembly is free of oil, allowing replacement without soiling hands. Further, since the fixing assembly is fixed in place without a screw, it may be removed by simply shifting the releasing lever.

2. Quick Replacement of Toner Cartridges

The Y, M, and C toner cartridges are designed as a 3-color rotary development construction so that they, including the black toner cartridge, may be replaced by the user without effort.

The black toner cartridge is a large-capacity cartridge—suitable for business uses, which require large volumes of black-and-white printing work.

3. Auto Duplexing Mechanism

The installation of a duplexing unit (accessory) will enable making double-sided prints (through-path configuration).

4. Reader Unit

The installation of the reader unit (accessory in some areas) will generate sharp prints at a resolution of 600 dpi x 600 lpi.

II. SPECIFICATIONS

A. Printer Unit

1. Type

Body	Desk-top page printer (console when installed to a paper deck)
Photosensitive medium	OPC drum (62-mm dia.)

2. System

Printing	Laser beam indirect photostatic reproduction (using an intermediate transfer drum)
Laser	Semiconductor laser
Scanning system	Scanning by 6-facet mirror
Charging	Roller charging
Exposure	Laser beam
Contrast adjustment	Auto
Development	Toner projection
Toner	Non-magnetic, single-component dry toner (Y, M, C) Magnetic, single-component dry toner (Bk)
Toner supply	By replacement of Y, M, C, and Bk toner cartridges
Pick-up	Special front cassette (2 holders), multifeeder
Transfer	Primary transfer: rubber blade Intermediate transfer drum: cleaning roller
Fixing	Heat roller (top: 595 W; bottom: 595 W (100/120 V)) (top: 550 W; bottom: 550 W (220/240 V))

3. Functions

Wait time		5 min or less	
First print time		See Table 1-201.	
Printing speed		See Table 1-202.	
Cassette		Universal cassette: about 500 sheets of 80 g/m ² R cassette (accessory): about 500 sheets of 80 g/m ²	
Multifeeder tray		about 10 mm in height (about 100 sheets of 80 g/m ²)	
Duplexing unit		Through-path (accessory)	
Delivery tray		Face-down: about 300 sheets (80 g/m ² paper), w/ limit sensor Face-up: about 100 sheets (80 g/m ² paper)	
Print size	Cassette 1	Universal cassette: LGL, B4, LTR, A4 Special cassette (accessory): LTRR, A4R, B5R, A5R	
	Cassette 2	Universal cassette: 11×17, A3, LGL, B4, LTR, A4	
	Multifeeder	Envelope, A3 (11×17) to A5 (if B5 and A5, horizontal only); 12×18.5	
Print paper	Cassette	Plain paper (60 to 105 g/m ²), colored paper, recycled paper	
	Multifeeder	Plain paper (60 to 105 g/m ²), transparency (special), thick paper (106 to 135 g/m ²), label sheet (special), envelope, colored paper, recycled paper	
	Double-sided printing	Duplexing unit (if installed) : A3 to B5R plain paper (60 to 105 g/m ²)	
Image margin		Single-sided	Double-sided
		Leading edge: 5.0 ±2.0 mm Trailing edge: 5.0 ±2.0 mm Left/right: 5.0 ±2.0 mm	Leading edge: 5.0 ±2.0 mm Trailing edge: 5.0 ±2.0 mm Left/right: 5.0 ±2.0 mm
Non-image width		Single-sided	Double-sided
		Leading edge: 5.0 ±2.0 mm Trailing edge: 5.0 ±2.0 mm Left/right: 5.0 ±2.0 mm	Leading edge: 5.0 ±2.0 mm Trailing edge: 5.0 ±2.0 mm Left/right: 5.0 ±2.0 mm
Resolution	Main scanning direction	600 dpi (dots per inch)	
	Sub scanning direction	600 lpi (lines per inch)	

4. Others

Operating environment	See p. 8-1.	
Power supply (rated voltage $\pm 10\%$)	Power supply	Serial No.
	120V (USA)	NLQ xxxxx
	120V (TWN)	NLX xxxxx
	230V (KOR)	PLC xxxxx
	230V (Others)	PLF xxxxx
	230V (CA)	
	230V (UK)	ULL xxxxx
	230V (FRN)	
	230V (GER)	
	230V (AMS)	
	230V (ITA)	
	Weight (printer unit only)	<p>91.6 kg (including drum cartridge weighing about 2.3 kg; black toner cartridge, about 1.5 kg; each color toner cartridge, about 1.2 kg)</p> <p>The duplexing unit weighs about 3.5 kg.</p>

(unit: sec or less)*

		4-color	Mono-color (YMCK)
Plain paper	A4/LTR	34	18
Thick paper	A4/LTR	50	35
Transparency	A4/LTR	57	41

Table 1-201 First Print Time

*A4, Direct, cassette 1, face-up delivery, no pre-scanning if face-down delivery, add 3 sec for plain paper, 6 sec for thick paper, and 7 sec for transparency.

(copies/min)

	Source	Size	4-color	Mono-color (YMCK)
Plain paper	Cassette Multifeeder	A3/B4/A4R/B5/A5R/ 11×17/LGL/LTRR	3	12
		A4/LTR	6	24
Thick paper	Multifeeder	A3/11×17	1.2	1.7
		A4/LTR	2.4	3.4
Transparency	Multifeeder	A4/LTR	2.1	2.8

Table 1-202 Printing Speed

The above specifications are subject to change for product improvement.

III. SAFETY OF LASER LIGHT

Radiation of laser light can be hazardous to human beings. To ensure safety, the machine's laser scanning system is sealed inside a protective housing and external covers, preventing leakage of laser light to the outside so that the user cannot be exposed to the machine's laser light as long as the printer unit is used normally.

The printer unit is certified as a Class I product under 1040.10 of Title 21 of the Code of Federal Regulations (USA) and a Class 1 laser product under IEC825.

Figure 1-301 shows the label attached to products certified to comply with the foregoing standards (120-V model).

Warning:

Do not insert a screwdriver or other tools with a high reflectance into the laser path when servicing areas around the laser scanning system.

Be sure to remove watches, rings, and the like before starting to service the machine.

The eye, if exposed to laser light, can suffer permanent damage.

The machine's laser light is a visible light. However, the following label is attached to covers that may reflect laser light. Pay special attention whenever servicing areas behind such covers.



Figure 1-301

This label is attached to those covers of the machine's laser scanning system which are used to protect against laser light.

IV. NAMES OF PARTS

A. External View

- Front View

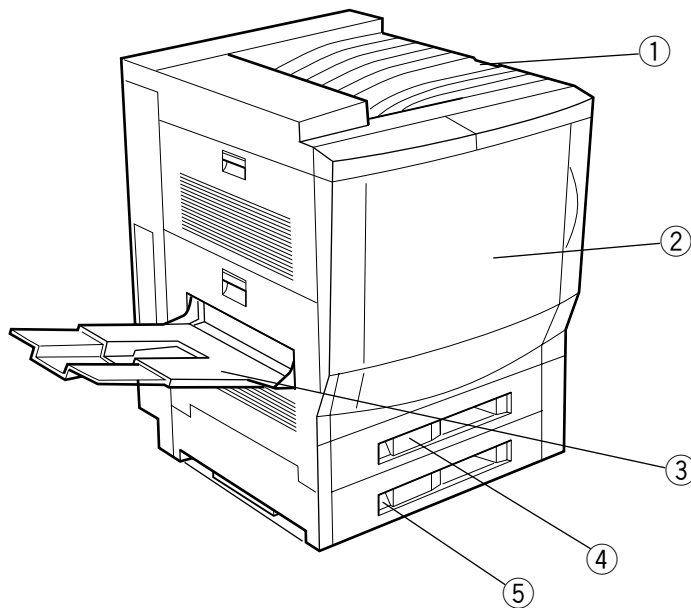

- ① Face-down tray
- ② Front cover
- ③ Face-up tray

- ④ Cassette 1
- ⑤ Cassette 2

Figure 1-401

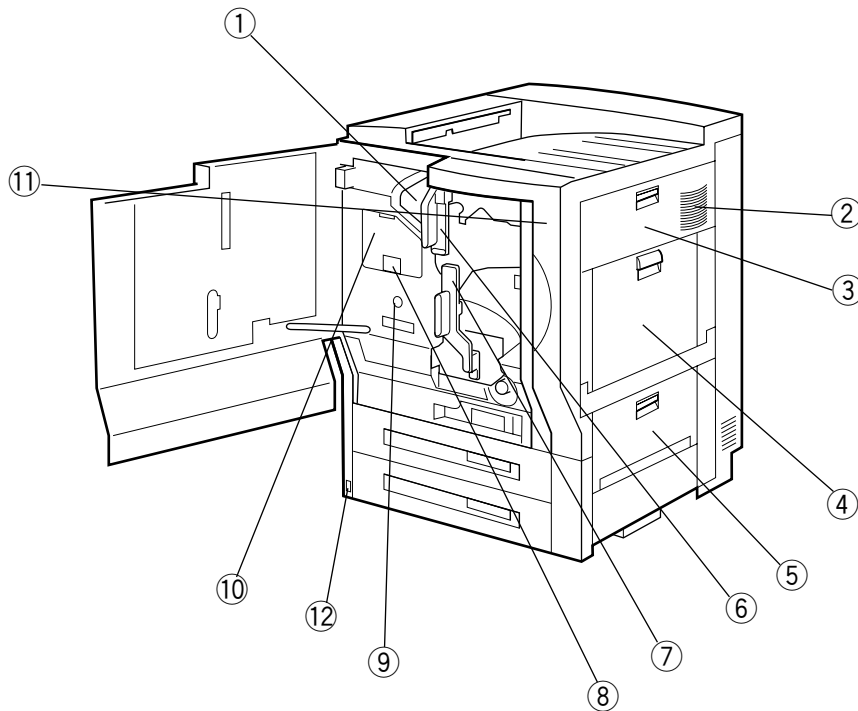

- | | |
|------------------------------|---|
| ① Black toner cartridge slot | ⑦ Bottom releasing lever |
| ② Exhaust vent | ⑧ Toner cartridge color check window |
| ③ Right cover | ⑨ Color cartridge replacement turret button |
| ④ Multifeeder | ⑩ Color cartridge cover |
| ⑤ Pick-up cassette cover | ⑪ Front right cover |
| ⑥ Top releasing lever | ⑫ Printer unit power switch |

Figure 1-402

• Back

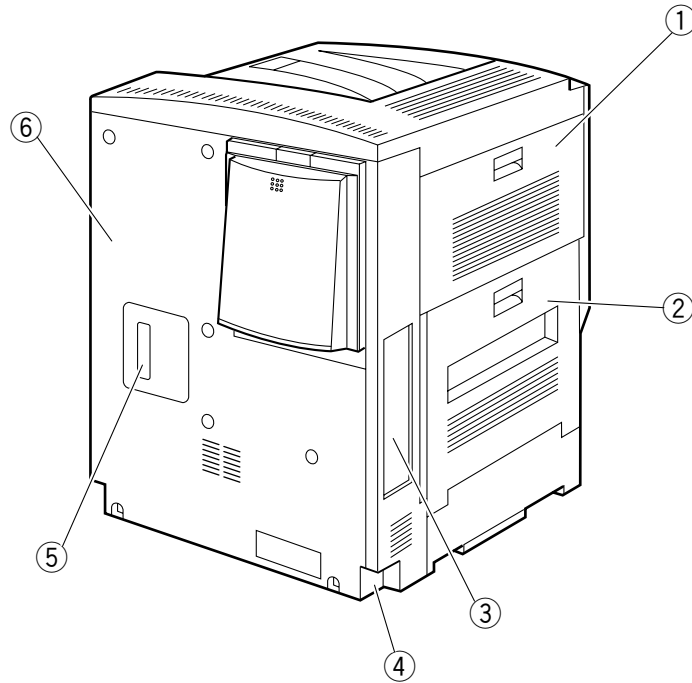

- | | |
|--------------------------|---|
| ① Upper left cover | ④ Power supply cord connector (printer unit) |
| ② Delivery cover | ⑤ Interface cable (for connection to the reader unit) |
| ③ Video controller cover | |
| | ⑥ Rear cover |

Figure 1-403

• Duplexing Unit

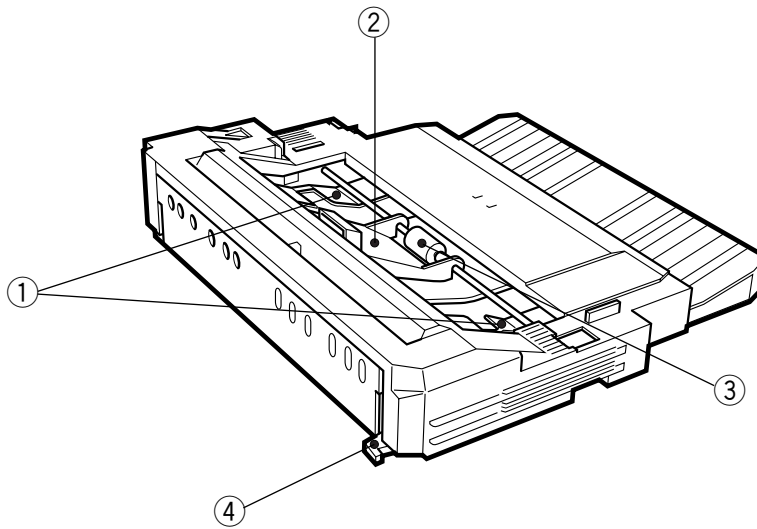

- ① Horizontal registration guide
- ② Pick-up guide plate
- ③ Duplexing feeding roller 1
- ④ Duplexing releasing lever

Figure 1-404

B. Cross Section

• Printer Unit

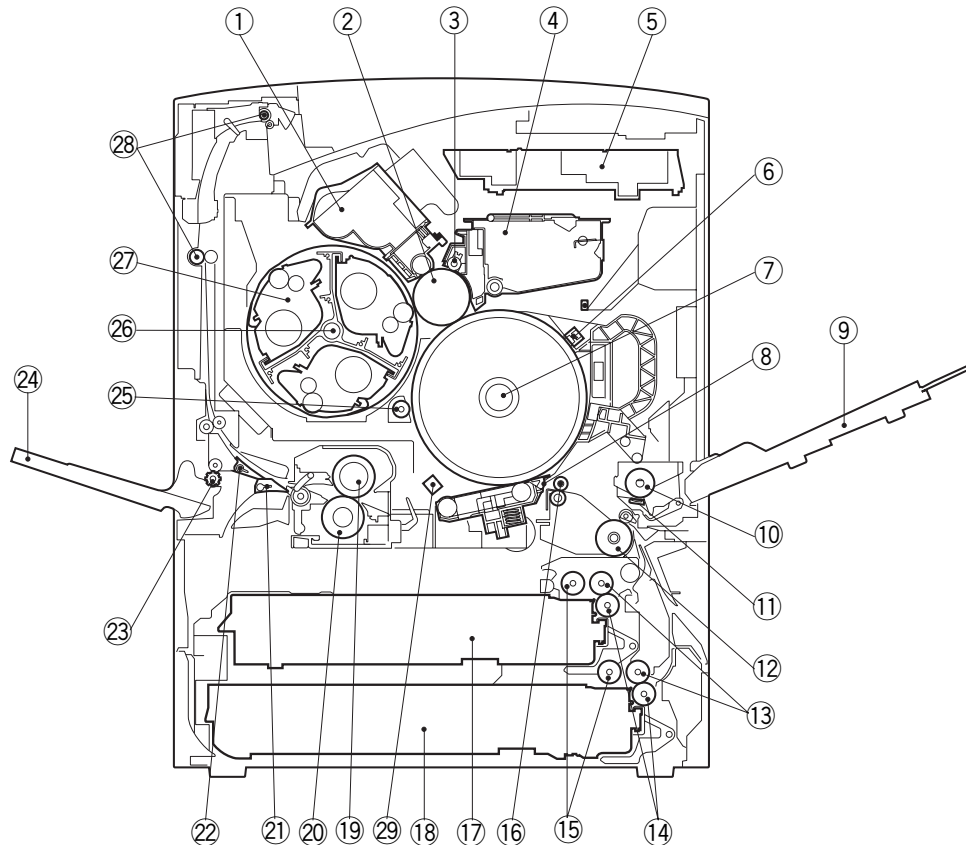

- | | |
|--|--|
| ① Black toner cartridge | ⑩ Multifeder pickup roller |
| ② Photosensitive drum | ⑪ Separation pad |
| ③ Primary charging roller | ⑫ Feeding roller 2 |
| ④ Photosensitive drum cartridge | ⑬ Feeding roller 1 |
| ⑤ Laser/scanner assembly | ⑭ Separation roller |
| ⑥ Secondary pre-transfer charging assembly | ⑮ Pick-up roller |
| ⑦ Intermediate transfer drum | ⑯ Upper fixing roller |
| ⑧ Secondary transfer belt | ⑰ Lower fixing roller |
| ⑨ Multifeder tray | ⑱ Duplexing flapper |
| ⑩ Multifeder pickup roller | ⑲ Upper fixing roller |
| ⑪ Separation pad | ⑳ Lower fixing roller |
| ⑫ Feeding roller 2 | ㉑ Color developing rotary |
| ⑬ Feeding roller 1 | ㉒ Color toner cartridge |
| ⑭ Separation roller | ㉓ Delivery roller |
| ⑮ Pick-up roller | ㉔ Separation static eliminator |
| | ㉕ Intermediate transfer drum (ITD) cleaning roller |
| | ㉖ Face-up tray |
| | ㉗ Face-up delivery roller |
| | ㉘ Face-up flapper |
| | ㉙ Cassette 1 |
| | ㉚ Cassette 2 |
| | ㉛ Registration roller |

Figure 1-405

• Duplexing Unit

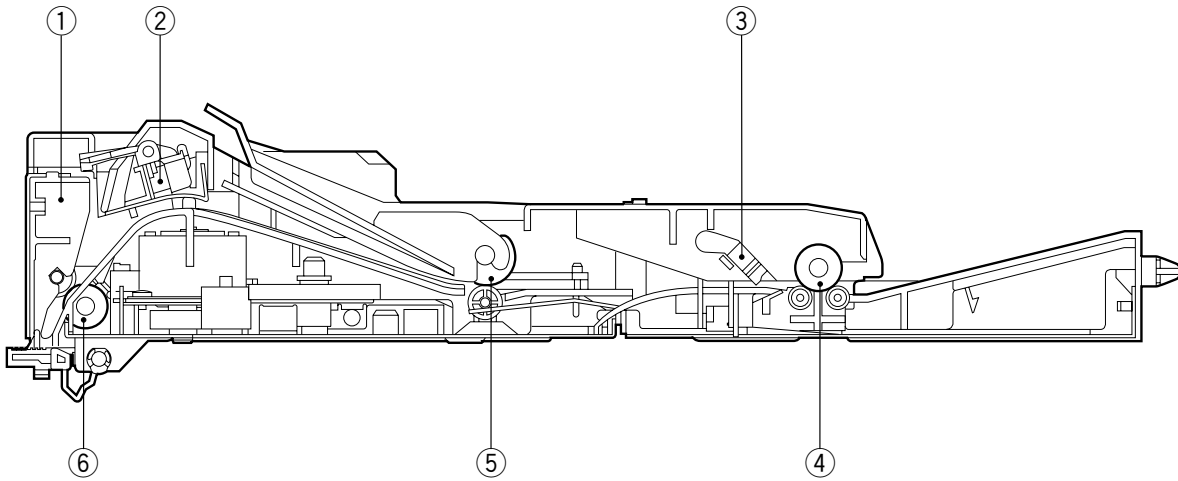

- ① Reversing roller releasing plate
- ② Reversal paper sensor
- ③ Re-pick up sensor lever
- ④ Duplexing feeding roller 2
- ⑤ Duplexing feeding roller 1
- ⑥ Reversing roller

Figure 1-406

V. USING THE CONTROL PANEL

The control panel on the top of the printer enables you to set options and view the status of the printer and print jobs.

For details, see the PS/PCL Board Service Manual.

Caution:

This control panel is available only when the printer unit is used as a printer after equipping it with a printer board, and is not available if the printer unit is used as a copier.

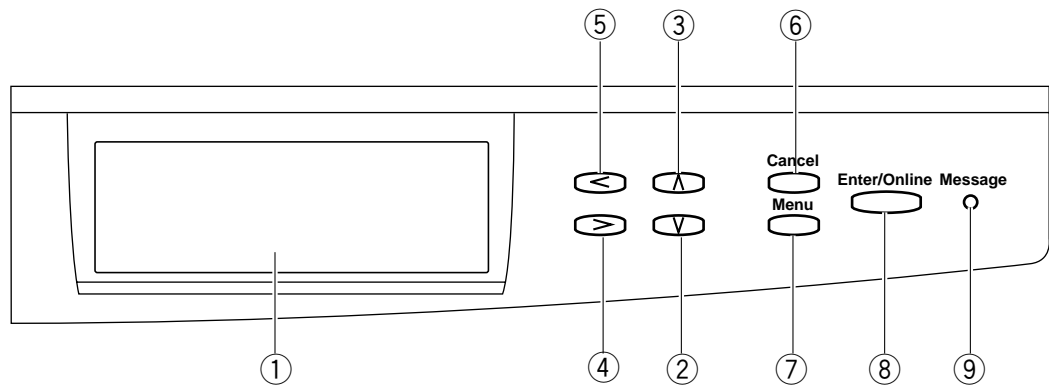

	Name	Operation/function	Remarks
①	Display window	The LCD window on the control panel displays status messages and a graphical representation of the printer.	
②	Down arrow button	In a fixed-length list, takes you to the next item in the list. When entering numbers or text, increments to the previous number or character. Hold down the button to increment rapidly.	
③	Up arrow button	In a fixed-length list, takes you to the previous item in the list. When entering numbers or text, increments to the previous number or character. Hold down the button to increment rapidly.	
④	Right arrow button	When entering numbers or text, advances the cursor.	
⑤	Left arrow button	When entering number or text, backspaces and deletes.	
⑥	Cancel button	In setup menus, exits menus entirely, returning to ready. While printing, cancels printing or processing the current job.	
⑦	Menu button/LED	Accepts an option and advances to the next choice. When the printer is in ready mode, takes the printer offline.	On when the printer is online (ready to accept and process new jobs), blinking when receiving, processing or printing data, and off when the printer is offline or the power is off.
⑧	Enter/Online button/LED	From ready or power saver mode, enters the setup menus. In setup menus, advances from one menu to the next. From a setup menu option, returns to the previous setup menu.	
⑨	Message LED	On when the printer requires a service call. Blinking when the printer requires operator intervention (e.g., load paper).	

VI. NOTES TO THE USER

If the printer unit is expected to remain out of use for a long time (e.g., holidays), be sure to shift up the fixing assembly releasing lever as shown to unlock the upper and lower rollers of the fixing assembly.

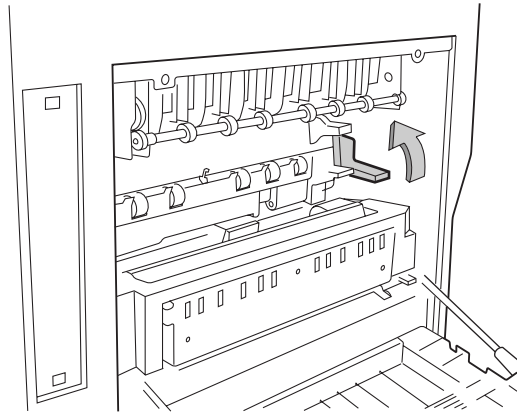

Figure 1-601 Fixing Assembly Releasing Lever

VII. NOTES TO THE SERVICE PERSON

A. Storing the Drum Cartridge and the Toner Cartridges

Regardless of whether they have been opened or not, the cartridges (Y, M, and C toner cartridges, black toner cartridge, and drum cartridge) remain subject to the influences of the environment, and their characteristics change over time. (This is also true regardless of how many copies/prints they have processed.)

The speed of change, however, is dependent on the conditions of the site and maintenance and, therefore, it is important to take full care when storing or handling them. (Be sure to instruct the user to be careful when storing and handling the toner cartridges.)

1. Before Opening the Package

When storing the cartridges (Y, M, and C toner cartridges, black toner cartridge, and drum cartridge) in a storeroom or a workshop, be sure that the place complies with the conditions in Table 1-601; in addition,

- 1) Avoid direct sunshine;
- 2) Avoid an area subject to appreciable vibration; and
- 3) Avoid subjecting them to impact by hitting or dropping.

Temperature	Normal (9/10 or more of entire storage period)		0 to 35°C
	Severe (1/10 or less of entire storage period)	High	35 to 40°C
		Low	-20 to 0°C
Changes in temperature (within 3-min period)			40°C → 15°C -20°C → 25°C
Humidity	Normal (9/10 or more of entire storage period)		35 to 85%
	Severe (1/10 or less of entire storage period)	High	85 to 95%
		Low	85 to 95%
Atmospheric temperature			613 to 1013 hPa (608 to 760 mmHg)
Entire storage period			1 yr

Table 1-701

Note: The term “entire storage period” means a period of one year from the date of manufacture indicated on the cartridge package.

2. After Opening the Package

The photosensitive drum is an organic photoconductor (OPC), and would deteriorate if subjected to strong light. The toner cartridges, on the other hand, contains toner, requiring care by the user for storing and handling after they have been opened.

3. Storage Environment (after opening)

- 1) Keep it in a protective bag.
- 2) Avoid direct sunshine. Avoid bright areas (e.g., near windows). Do not leave them inside a car for a long time, as the inside can become extremely hot.
- 3) Avoid high-temperature, high-humidity, low-temperature, or low-humidity areas and areas in which temperature or humidity change rapidly.
- 4) Avoid areas subject to corrosive gas (e.g., insecticide) or briny air.
- 5) Make sure the cartridges are kept between 0° and 35°C.
- 6) Do not place the cartridges near a CRT screen, disk drive, or floppy disks.
- 7) Keep the cartridges out of reach of children.

4. Service Life

The service life of a cartridge is 2.5 years from the date of manufacture, indicated by means of an abbreviation on the cartridges.

For the user, a “service life,” obtained by adding 2.5 years to the date of manufacture, is indicated on the package and the cartridge itself.

Prints made using a cartridge older than its service life may have low image quality, making it important to use up each cartridge before the end of its service life.

B. Points to Note When Handling the Drum Cartridge and the Toner Cartridges

- 1) When setting a new toner cartridge (Y/M/C toner cartridge, black toner cartridge) in the printer unit or if white spots occur on output prints because of uneven toner inside a cartridge, hold the cartridge horizontal and rotate it slowly up and down (about 45°) five to six times to even out the toner. (Instruct the user to observe this. In addition, inform the user that handling a toner cartridge other than the foregoing method can cause leakage of toner from the developing cylinder.)

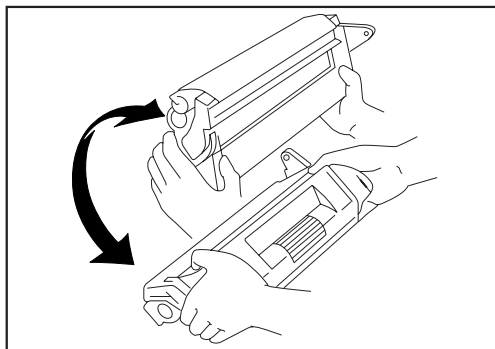

Black toner cartridge

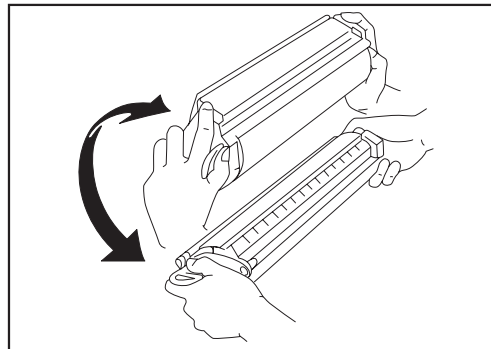

Y/M/C toner cartridge

Figure 1-701

- 2) Remove all cartridges if the printer unit must be moved.
In the case of the drum cartridge, put the special protective cover (MF4-0106-000) after taking it out of the printer unit, and put it in a protective bag or wrap it in a thick cloth to prevent exposure to light.
- 3) Do not place the black toner cartridge near a CRT screen, disk drive, or floppy disks. The magnetic field it generates can damage the data.
- 4) Do not expose the drum cartridge to direct sunshine or strong light. Doing so could affect print images.
- 5) Do not touch the surface of the photosensitive drum of the drum cartridge.
- 6) Do not place the cartridge on its side or turned over. Be sure that the label side faces up.
- 7) Do not disassemble the cartridges.

- 8) Do not touch the two waste toner detecting windows of the drum cartridges.

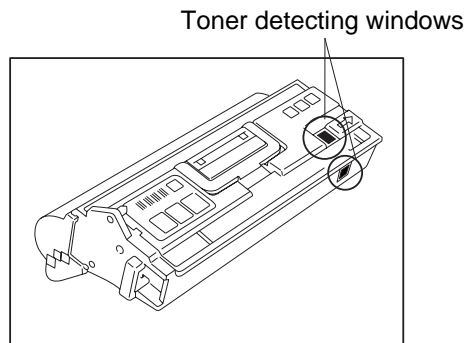

Figure 1-702

- 9) Do not touch the protection shutter of the toner cartridge.

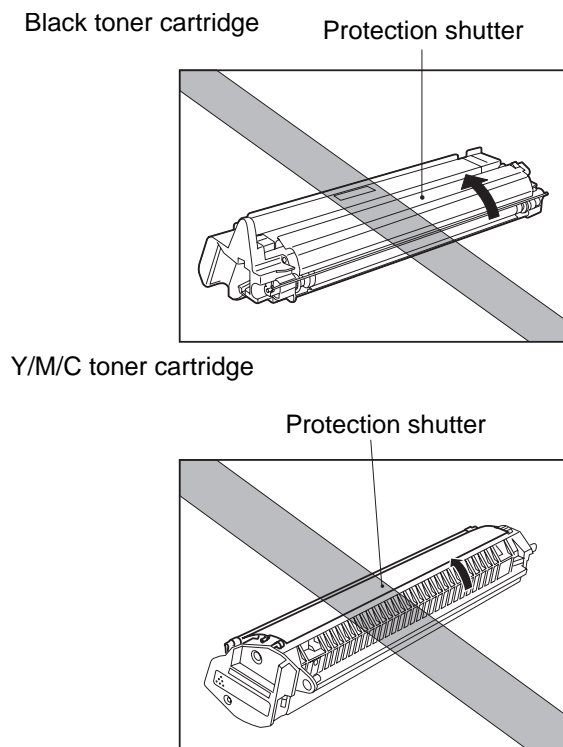

Figure 1-703

VIII. IMAGE FORMATION

A. Outline

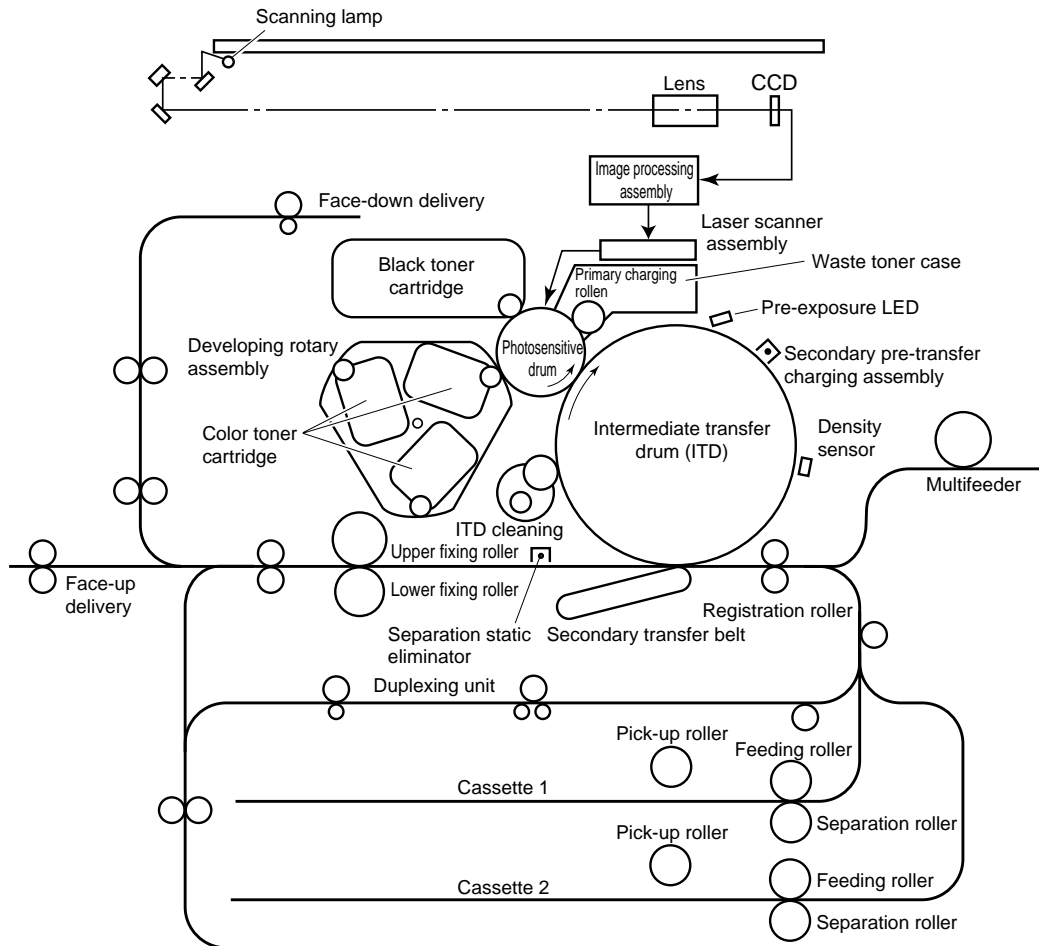

Figure 1-801

The machine's photosensitive medium is a seamless drum, and is constructed as shown in Figure 1-701. The photosensitive drum consists of a photoconducting layer (organic photosensitive conductor, OPC) on the outside and an aluminum base (conductor) on the inside.

The printer unit forms images as follows:

A color original is exposed to light, and the light reflected by the original is separated into three primary colors for detection by a CCD. Using the data from the CCD, a laser beam is directed to the photosensitive drum to develop a specific color (complementary of the filter in question), and the resulting image is transferred to the intermediate transfer drum (primary transfer). This series of processes is repeated for each color (Y, M, C, and Bk) in sequence.

The toner image on the intermediate transfer drum is then transferred to paper (secondary transfer), and fused to generate a color print.

The machine's image formation processes can be grouped into the following six blocks (12 steps):

- | | |
|--|---|
| <p>1. Latent Static Image Formation Block
 Step 1: pre-exposure
 Step 2: primary charging
 Step 3: laser beam exposure</p> | <p>4. ITD (intermediate transfer drum) cleaning block
 Step 9: ITD cleaning roller charging
 Step 10: ITD cleaning</p> |
| <p>2. Development Block
 Step 4: development</p> | <p>5. Photosensitive Drum Cleaning Block
 Step 11: drum cleaning</p> |
| <p>3. Transfer Block
 Step 5: primary transfer
 Step 6: secondary pre-transfer charging
 Step 7: secondary transfer
 Step 8: separation</p> | <p>6. Fixing Block
 Step 12: fixing</p> |

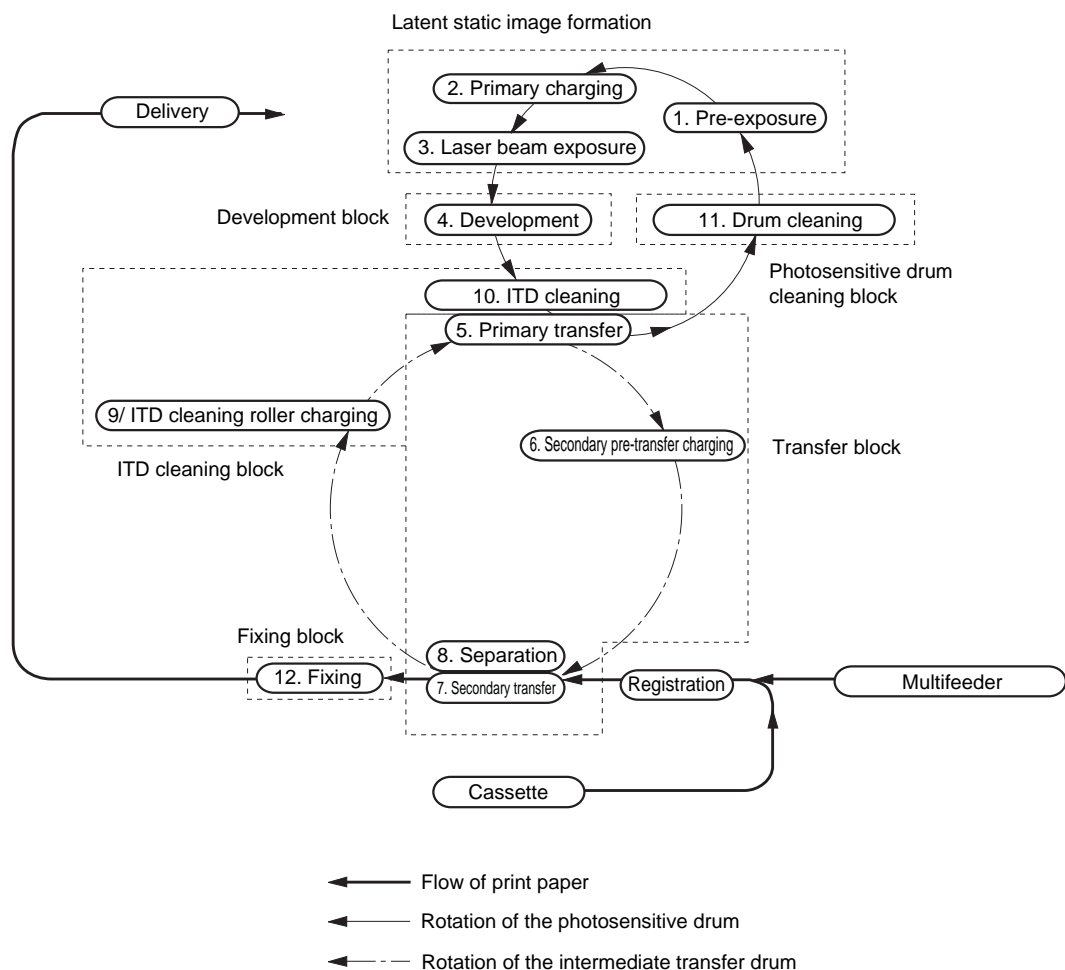

Figure 1-802

B. Latent Static Image Formation Block

This block consists of three steps, performed to generate a latent static image on the photosensitive drum.

At the end of the last step in this block, the dark areas of the drum which have not been exposed to the laser beam retain negative charges, while the light areas of the drum which have been exposed to the laser beam are rid of negative charges.

The image on the drum formed by negative charges is not visible to the human eye, and therefore is called "latent static image."

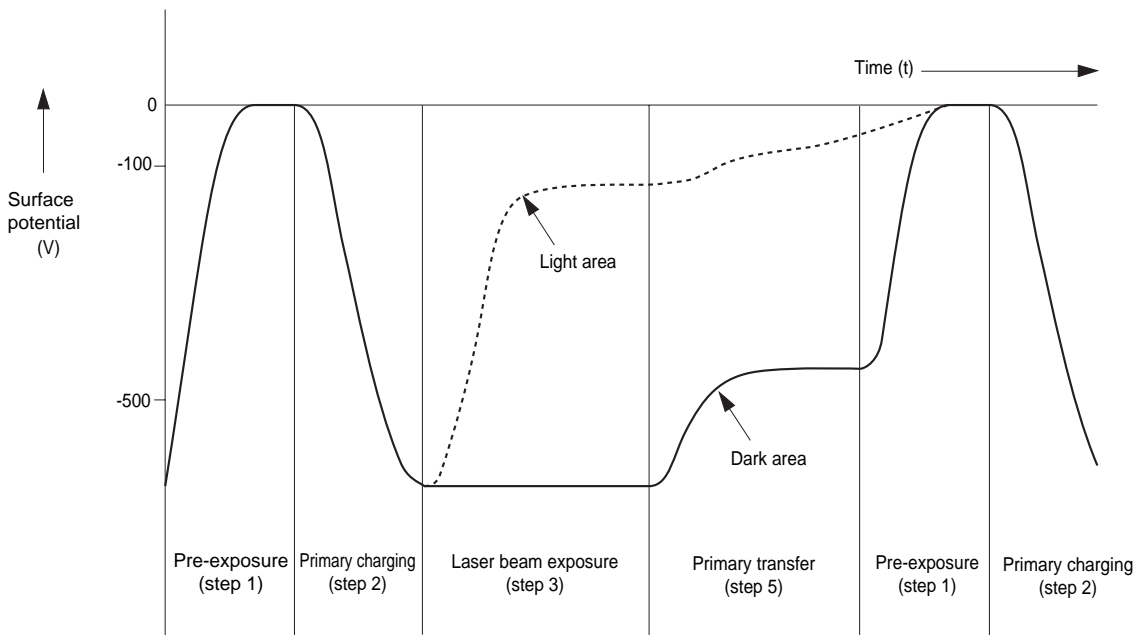
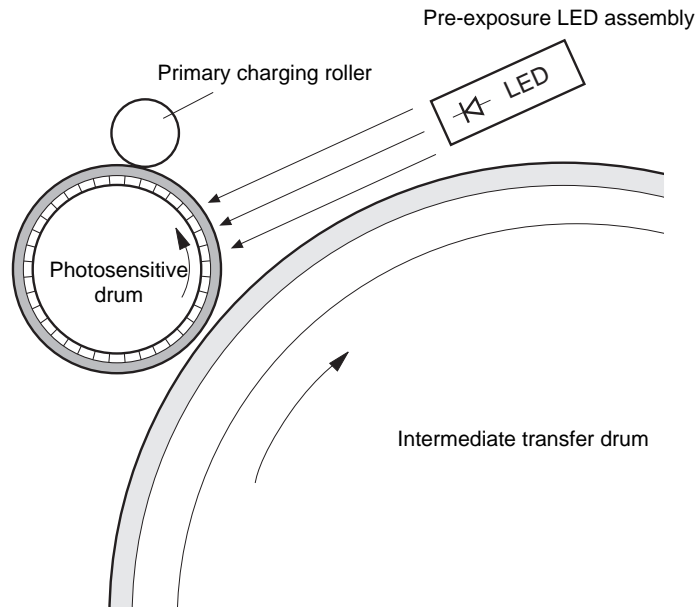

Figure 1-803

Step 1 (pre-exposure)

In preparation for primary charging, the light from the pre-exposure LED assembly is directed to the surface of the photosensitive drum to remove the residual charges from the surface, thereby preventing uneven density.

**Figure 1-804**

Step 2 (primary charging)

In preparation for laser beam exposure, the surface of the photosensitive drum is charged to a uniform negative potential. The machine's primary charging consists in directly charging the photosensitive drum.

The primary charging roller is given a AC bias, in addition to the DC bias, to ensure that the potential on the surface of the photosensitive drum will be uniform.

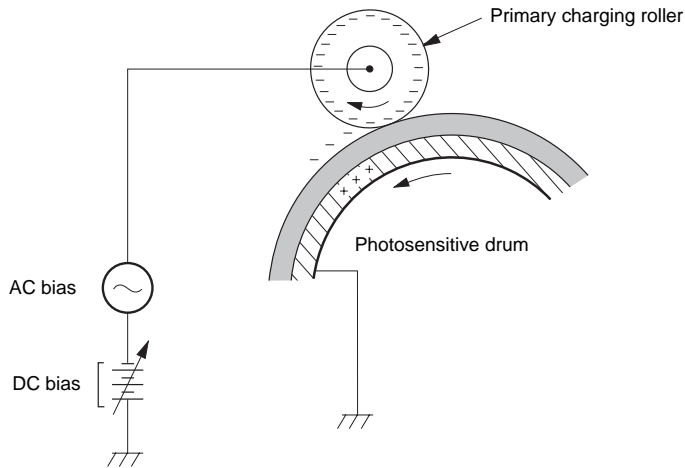

Figure 1-805

Step 3 (laser beam exposure)

When a laser beam is directed to the photosensitive drum, the charges in its light area become neutralized, turning the area into a latent static image.

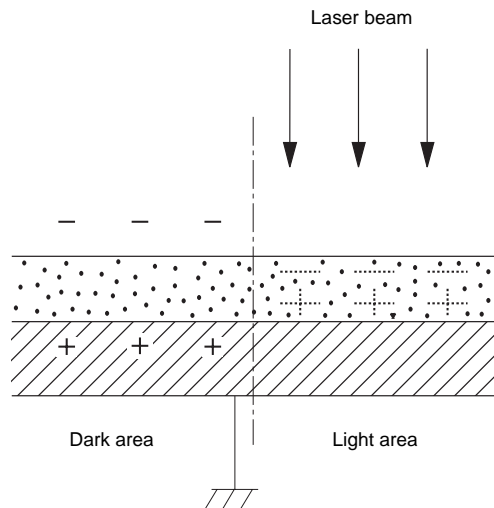

Figure 1-806

C. Development Block

In this block, toner is deposited on the latent static image on the surface of the photosensitive drum, thereby turning it into a visible image. The machine's black toner is a magnetic, single-component toner, and its color toner is non-magnetic, single-component toner; the printer unit uses the toner projection method of development.

Step 4 (development)

As previously mentioned, the machine's black toner is a magnetic, signal-component toner consisting of magnetite and resin. Its color toner, on other hand, is a non-magnetic single-component toner composed of resin. These toners have insulating characteristics, and are negatively charged by friction against the surface of a rotating cylinder and the surface of a blade.

The color toner may be yellow, magenta, or cyan, and is in a specific toner cartridge. The color toner cartridge is housed in a developing rotary, and the rotation of the rotary positions each cartridge against the photosensitive drum.

The black toner cartridge is mounted outside the developing rotary, and is positioned against the photosensitive drum at all times.

When an area of the photosensitive drum exposed to a laser beam approaches a toner layer (charged to negative potential), the difference in potential between the surface of the drum and the developing cylinder (higher on the drum side) causes the toner to jump and adhere the surface of the drum. This is called "jumping development," and turns the latent static image on the surface of the photosensitive drum into a visible image.

The developing cylinder is given an AC bias to facilitate movement of toner to the surface of the photosensitive drum and to improve contact on output images. The DC bias applied to the developing cylinder is varied in reference to the result of image density correction control (p. 4-21) executed on the DC controller PCB.

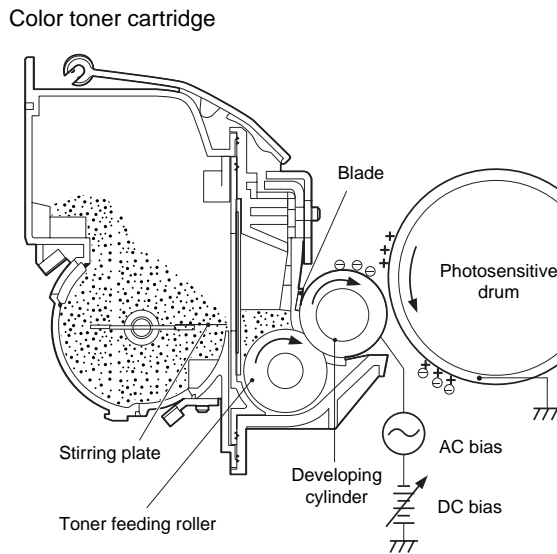
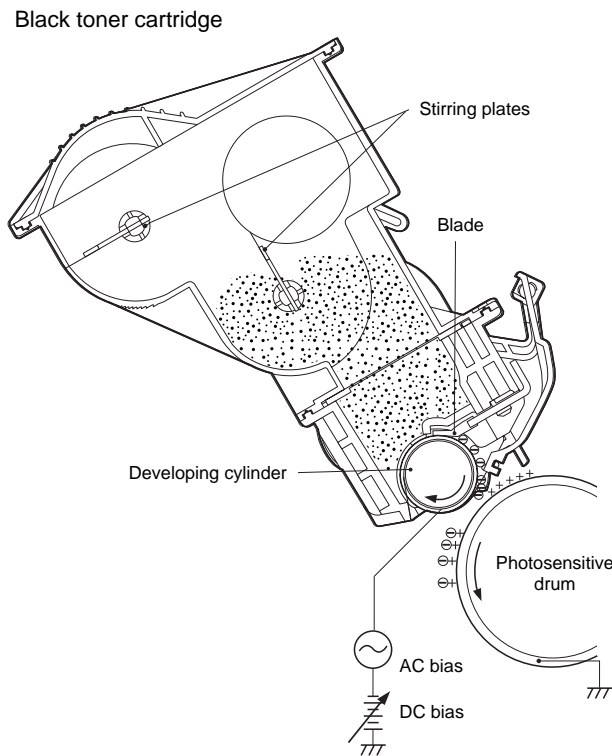

Figure 1-807

Caution:

Although the light area on the surface of the photosensitive drum is expressed as having positive potential, it in practice is charged to a negative potential. (When the potential of the cylinder is used as the reference, the potential of the photosensitive drum is higher than that of the cylinder.)

D. Transfer Block

In this block, the toner image on the surface of the photosensitive drum is transferred to paper by way of the intermediate transfer drum.

Step 5 (primary transfer)

The intermediate transfer drum is charged to positive potential from its inside to move the toner from the surface of the photosensitive drum to the intermediate transfer drum. This process is repeated for each color (Y, M, C, Bk) in sequence.

A DC bias (positive) is applied to the intermediate transfer drum during printing operation.

In the case of printing in full color, four layers of toner (four colors) are deposited on the intermediate transfer drum ready for primary transfer, requiring strengthening toner transfer for the second and subsequent colors, as toner with negative potential will increase on the intermediate transfer drum. To this end, the DC bias (positive) is increased for the second and the subsequent colors when printing in full color.

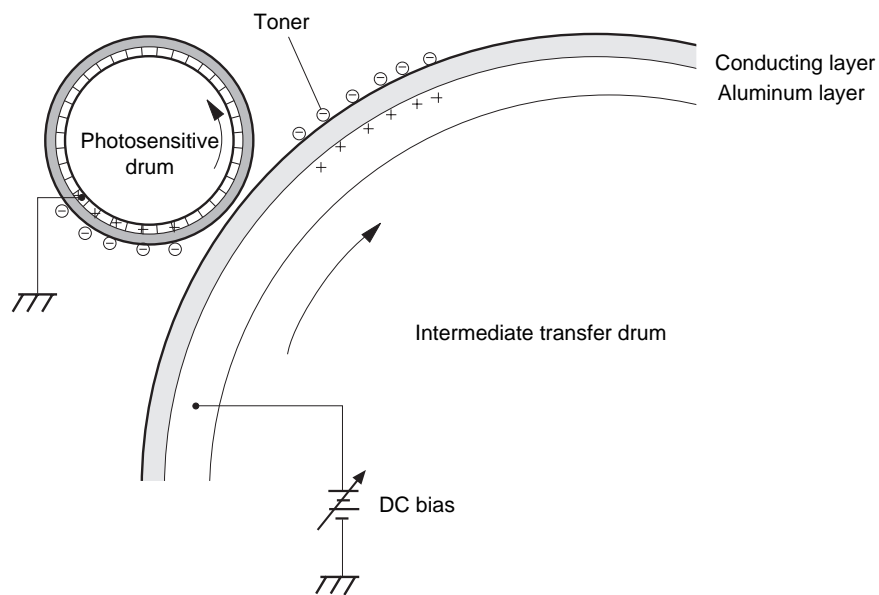

Figure 1-808

Step 6 (secondary pre-transfer charging)

A combination of an AC bias and a DC bias is applied to the secondary pre-transfer charging assembly so that each color toner on the intermediate transfer drum will receive an appropriate bias, thereby ensuring good secondary transfer.

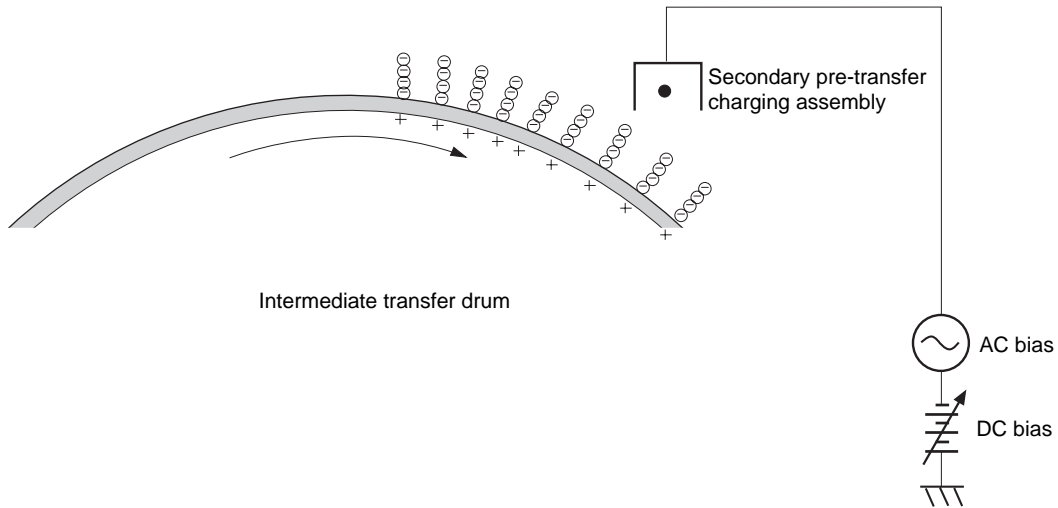

Figure 1-809

Step 7 (secondary transfer)

In this step, the toner on the intermediate transfer drum is transferred to paper, which is forced against the intermediate transfer drum by the secondary transfer belt assembly pushed up by the secondary transfer belt cam.

In this step, continuous application of a positive bias on the secondary transfer belt causes the surface of the belt to take on a negative potential, possibly leading to separation faults if left unattended. To prevent faults, a negative DC bias is applied at the end of secondary transfer for removing charges from the belt.

During multiple initial rotation, a negative DC bias is applied to prevent soiling the back of paper; i.e., the toner adhering to the surface of the secondary transfer belt is returned to the intermediate transfer drum.

To prevent excessive increases of charges on the transfer belt caused by continuous application of positive DC bias on the secondary transfer belt, a negative DC bias is applied to the separation charging assembly to remove charges from the belt at the end of secondary transfer.

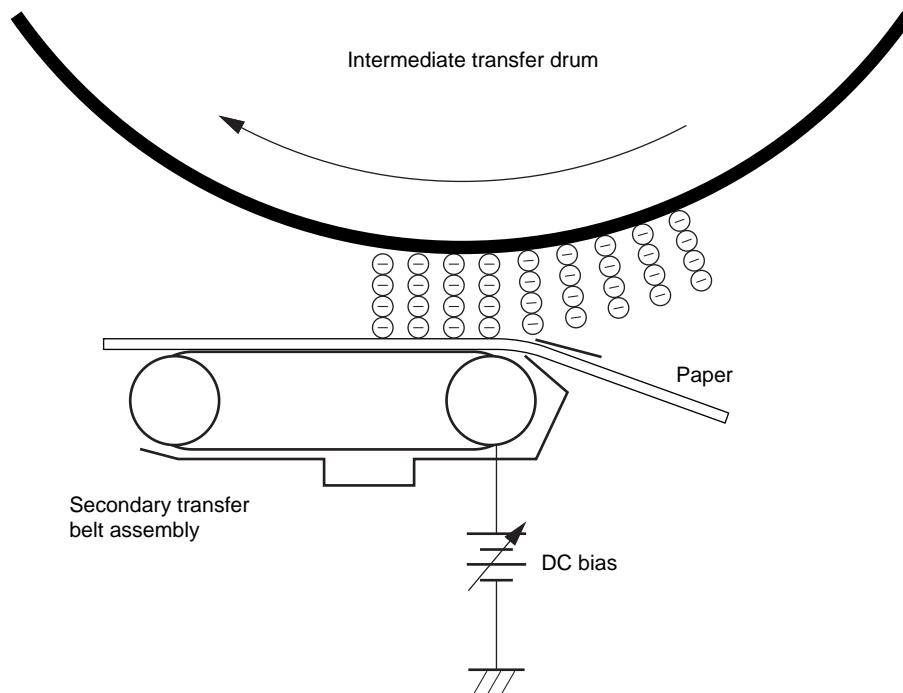

Figure 1-810

Step 8 (separation)

Paper is attracted to the secondary transfer belt to separate it from the intermediate transfer drum.

To suit the type of paper and the selected environmental parameters, an AC bias is applied to the separation static eliminator to prevent stray images (toner) caused by charges used to separate paper from the secondary transfer belt.

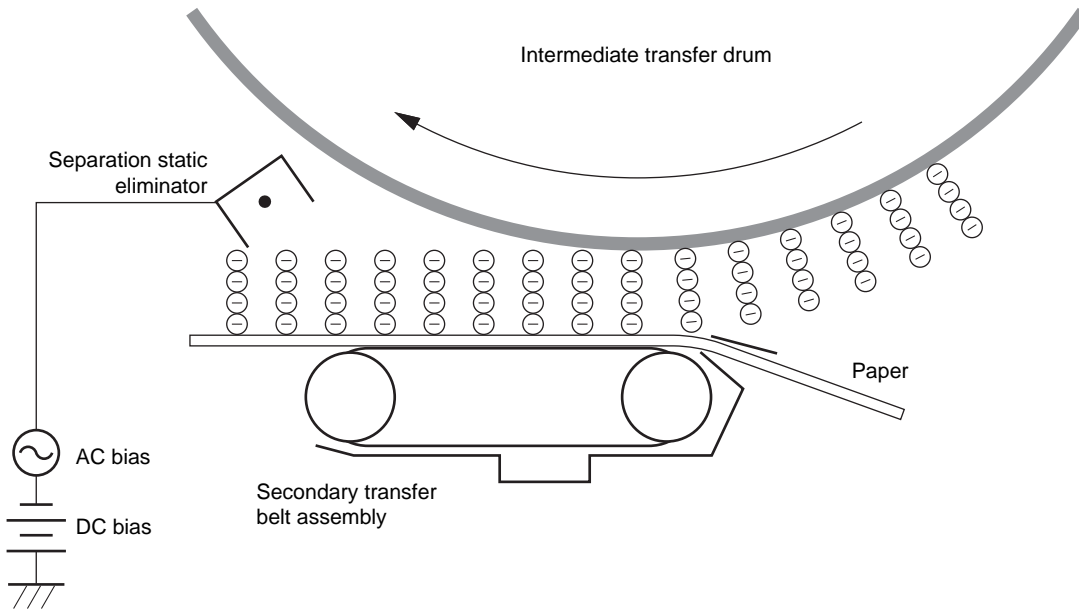

Figure 1-811

E. ITD (intermediate transfer drum) Cleaning Block

This block consists of two steps, cleaning the intermediate transfer drum by returning the residual toner from the intermediate transfer drum to the photosensitive drum.

Note:

In the secondary transfer block, the toner on the intermediate transfer drum is transferred to paper, leaving a minute amount of toner behind. At the end of image stabilization correction control or after a jam, further, the intermediate transfer drum remains coated with toner. All such toner is referred to as "residual toner."

Step 9 (ITD cleaning roller charging)

In this step, a bias is applied to the ITD cleaning roller as needed to charge the residual toner on the intermediate transfer drum to a uniform potential.

Normally, the ITD cleaning roller is held away from the intermediate transfer drum. It is brought into contact with the intermediate transfer drum by means of the ITED cleaning roller cam for ITD cleaning roller charging; at this time, a positive bias is applied to the ITD cleaning roller to charge the toner on the intermediate transfer drum to a uniform potential.

At the end of charging, the bias is turned off and, at the same time, the cleaning roller cam is driven to move the ITD cleaning roller away from the intermediate transfer drum.

At the end of printing, a negative bias is applied to remove the residual toner adhering to the ITD cleaning roller.

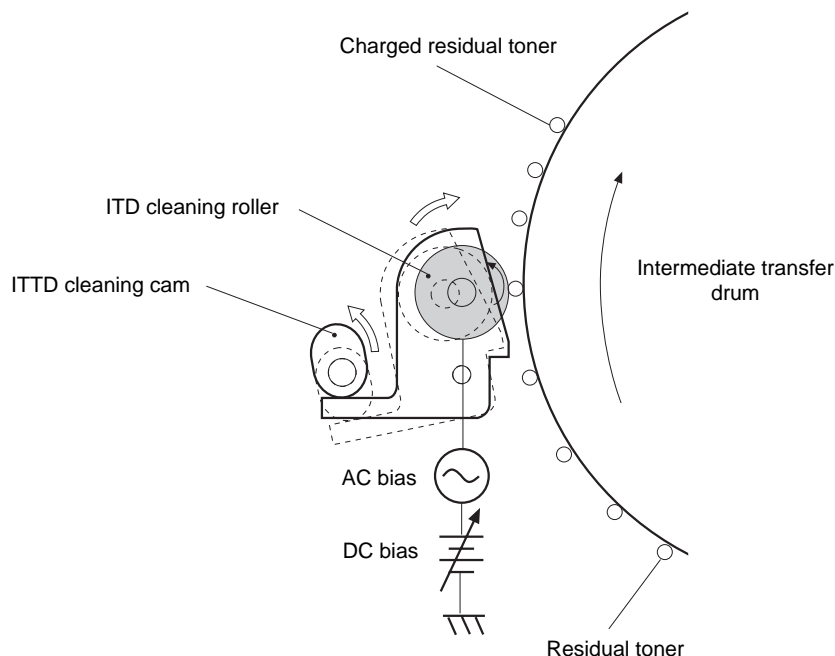
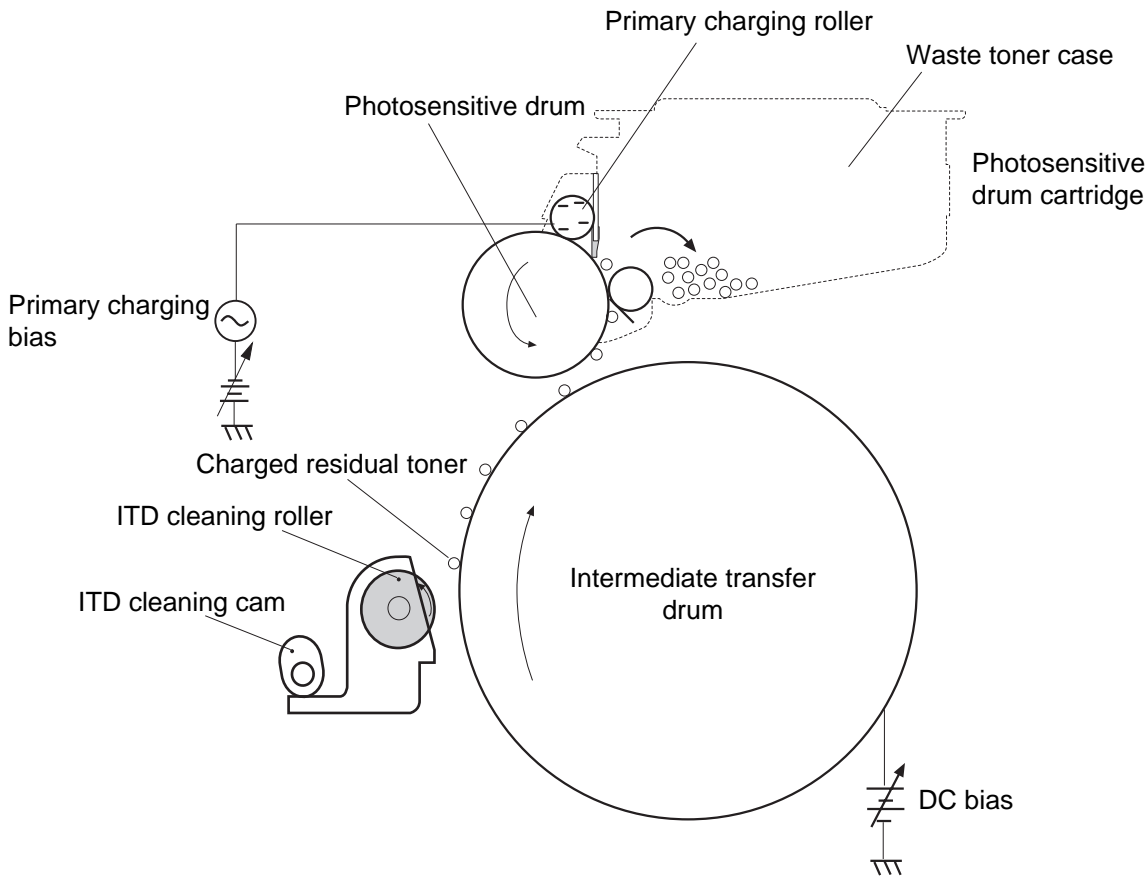

Figure 1-812

Step 10 (intermediate transfer drum cleaning)

In this step, different biases are applied to the intermediate transfer drum and the photosensitive drum to return the residual toner (charged to a uniform potential by the cleaning roller) existing on the intermediate transfer drum back to the photosensitive drum. The resulting difference in potential between the photosensitive drum and the intermediate transfer drum causes the residual toner to move from the intermediate transfer drum to the transfer drum.



Intermediate transfer drum potential > Photosensitive drum potential

Figure 1-813

F. Photosensitive Drum Cleaning

In the primary transfer step, not all toner on the photosensitive drum is transferred to the intermediate transfer drum, but some remains on the drum. The same is true of the secondary transfer step, in which not all toner on the intermediate transfer drum is transferred to paper—residual toner remains on the intermediate transfer drum after ITD cleaning.

In the photosensitive drum cleaning block, the surface of the photosensitive drum is cleaned in preparation for the next printing run, thus ensuring continuous reproduction of sharp images.

Step 11 (photosensitive drum cleaning)

In this step, the residual toner on the drum surface is scraped off by a cleaning blade in preparation for the next printing run. The scraped toner is collected by a scoop-up sheet, and is sent to the waste toner case by the waste toner feeding roller 1, waste toner feedscrew, and waste toner feeding roller 2.

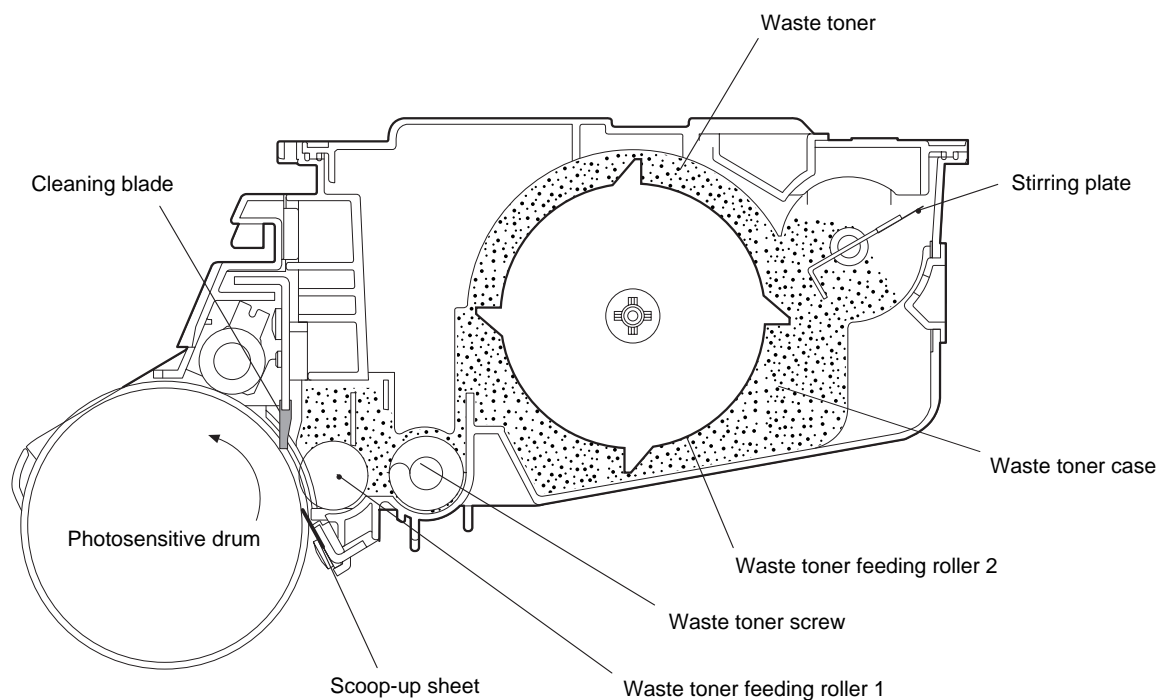

Figure 1-814

G. Fixing Block

The toner image transferred to paper in the transfer block merely “sits” on the paper by the work of static electricity, and would collapse if subject to the slightest impact.

In this block, the four color toners are fused into the fibers of the paper so that they will turn into a permanent image.

Step 12 (fixing)

The surface of the upper and lower rollers is coated with Teflon tubing material with good separation characteristics.

A negative DC bias is applied to the upper fixing roller to prevent toner on the paper from sticking to the rollers.

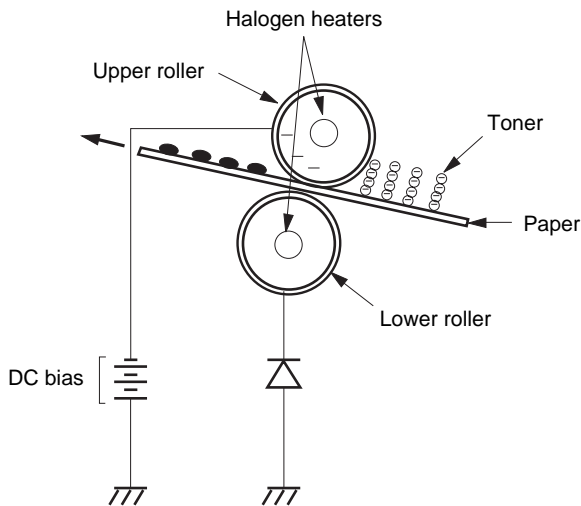

Figure 1-815

CHAPTER 2

BASIC OPERATION

This chapter provides descriptions on basic operations, functions of each operation, relationships between electrical and mechanical systems, and timing at which each associated part is turned on.

I. BASIC OPERATIONS	2-1	D. Basic Sequence of Operations (used as a printer).....	2-14
A. Functional Construction	2-1	E. Controlling the Main Motor.....	2-19
B. Electrical Circuitry	2-2		
C. Inputs to and Outputs of the Major PCBs	2-3		

I. BASIC OPERATIONS

A. Functional Construction

The printer unit consists of four functional blocks: pick-up/feeding system, laser exposure system, image formation system, and control system.

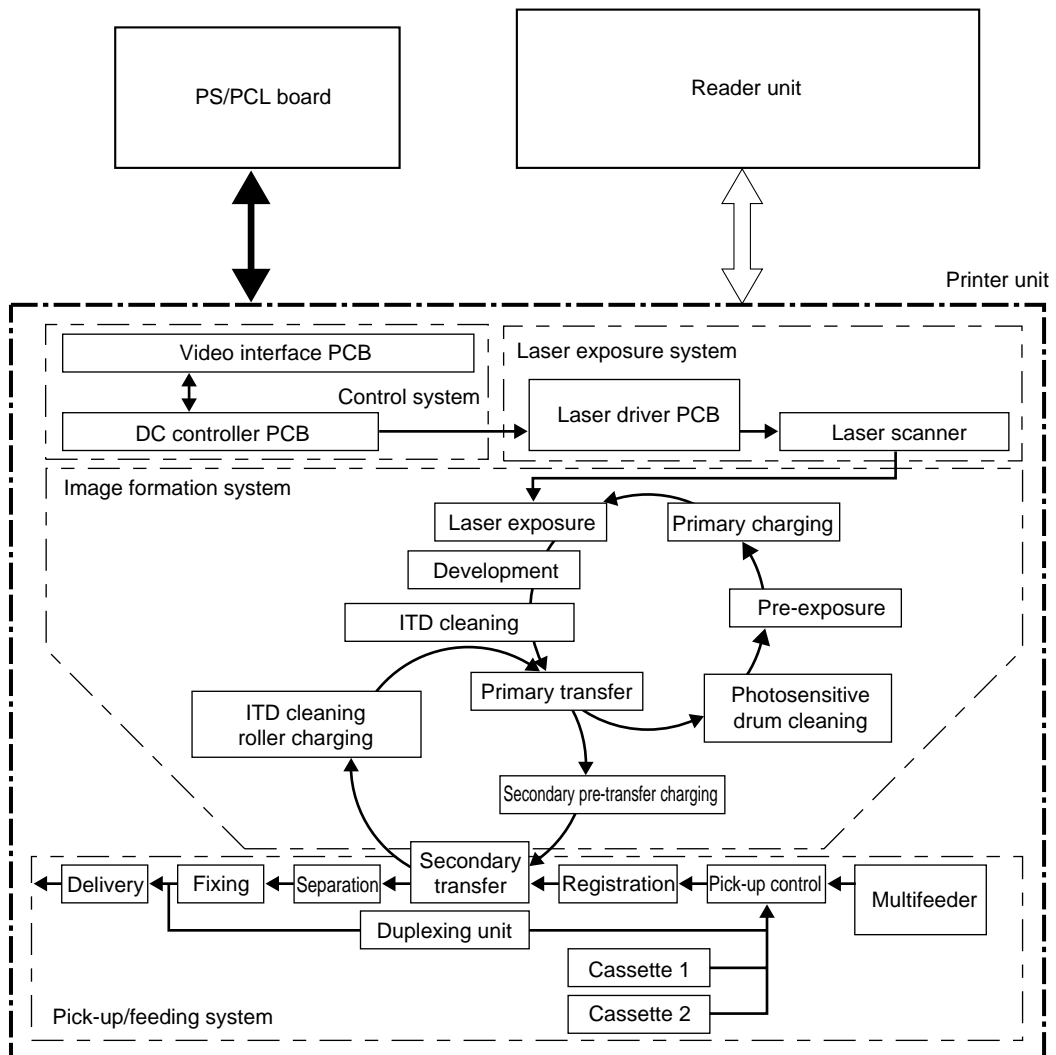
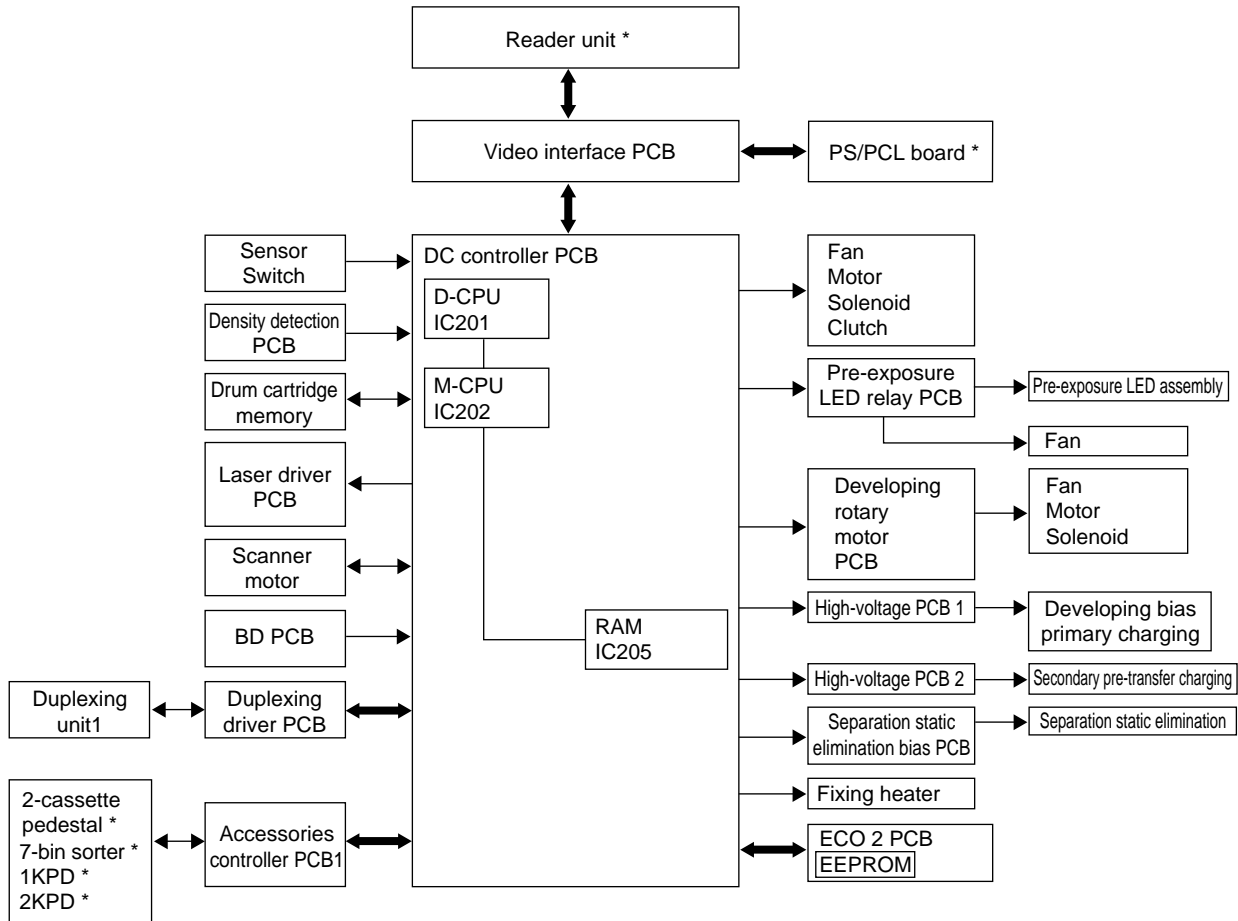

Figure 2-101

B. Electrical Circuitry

The machine's electrical mechanisms are controlled by the two CPUs (Reference) on the DC controller PCB.



* Available as an accessory in some areas.

Figure 2-102

Reference:

The two CPUs on the DC controller PCB have the following functions:

1. D-CPU (IC201)
 - System control for the printer unit.
 - Video interface control (communication with the printer board PS/PCL).
2. M-CPU(IC202)
 - Drive control for various loads (motor, solenoid).
 - Control of the fixing heater.
 - Control of the duplexing unit (accessory).

C. Inputs to and Outputs of the Major PCBs

1. Inputs to and Outputs from the DC Controller (1/10)

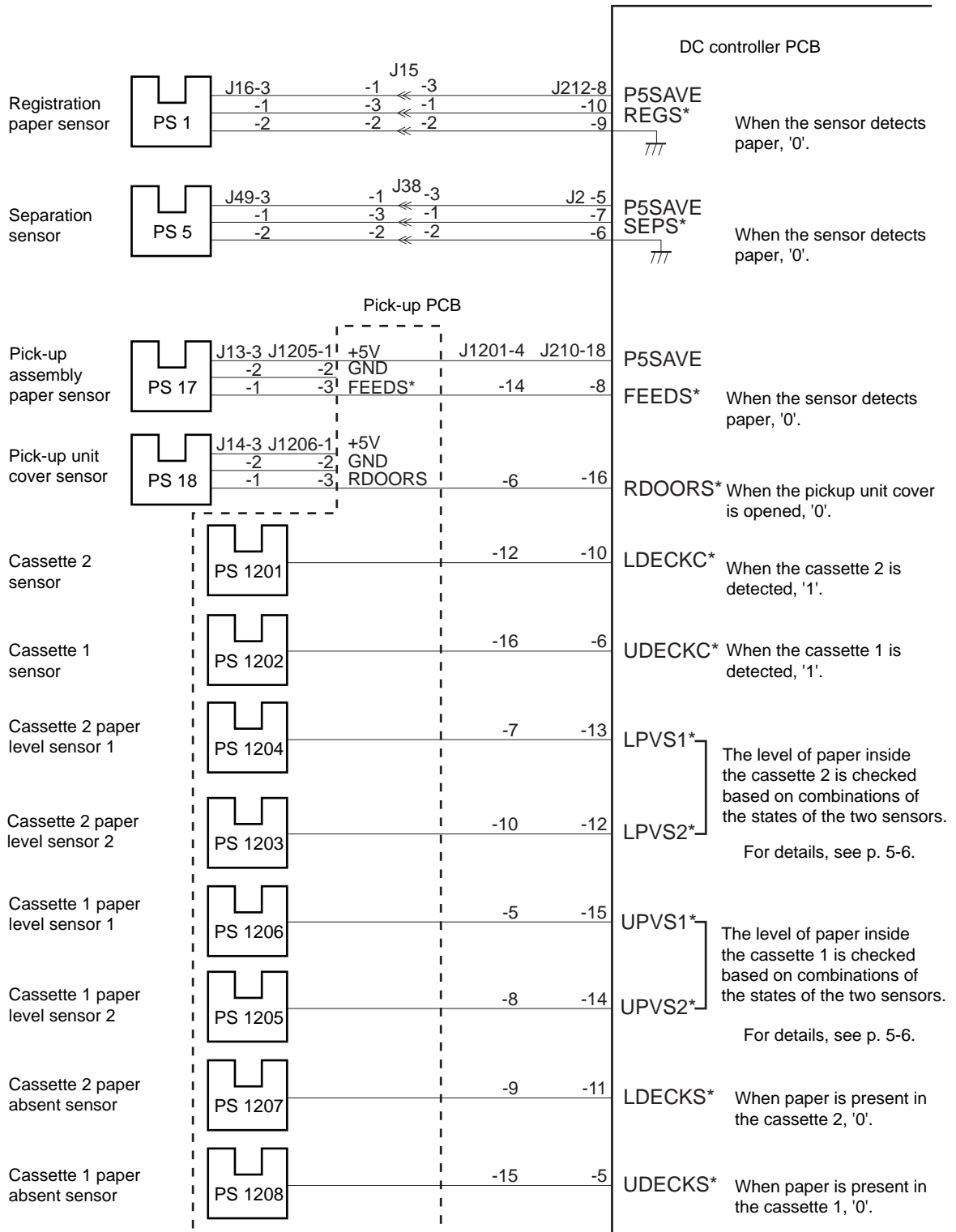

Figure 2-103

Inputs to and Outputs from the DC Controller PCB (2/10)

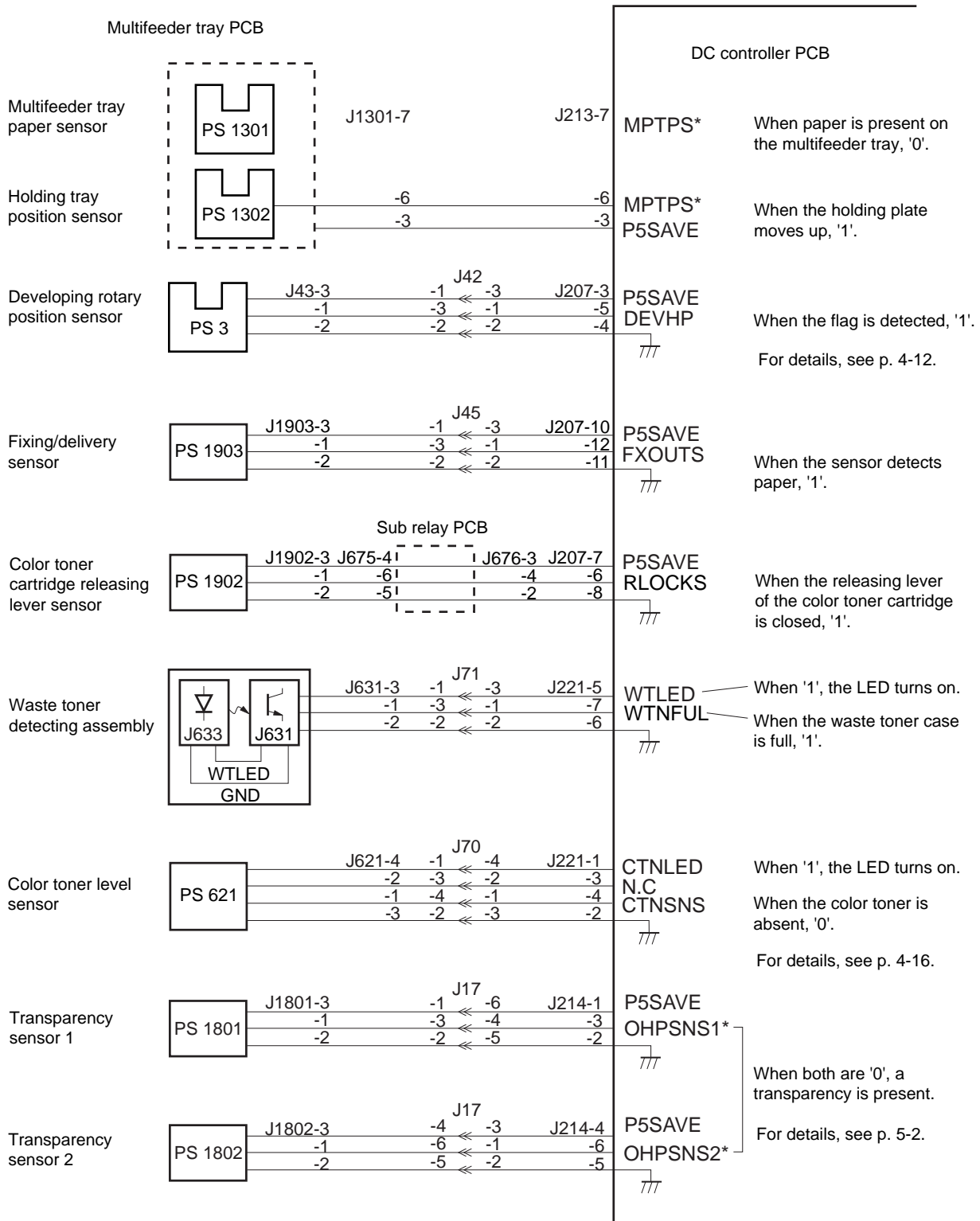

Figure 2-104

Inputs to and Outputs from the DC Controller PCB (3/10)

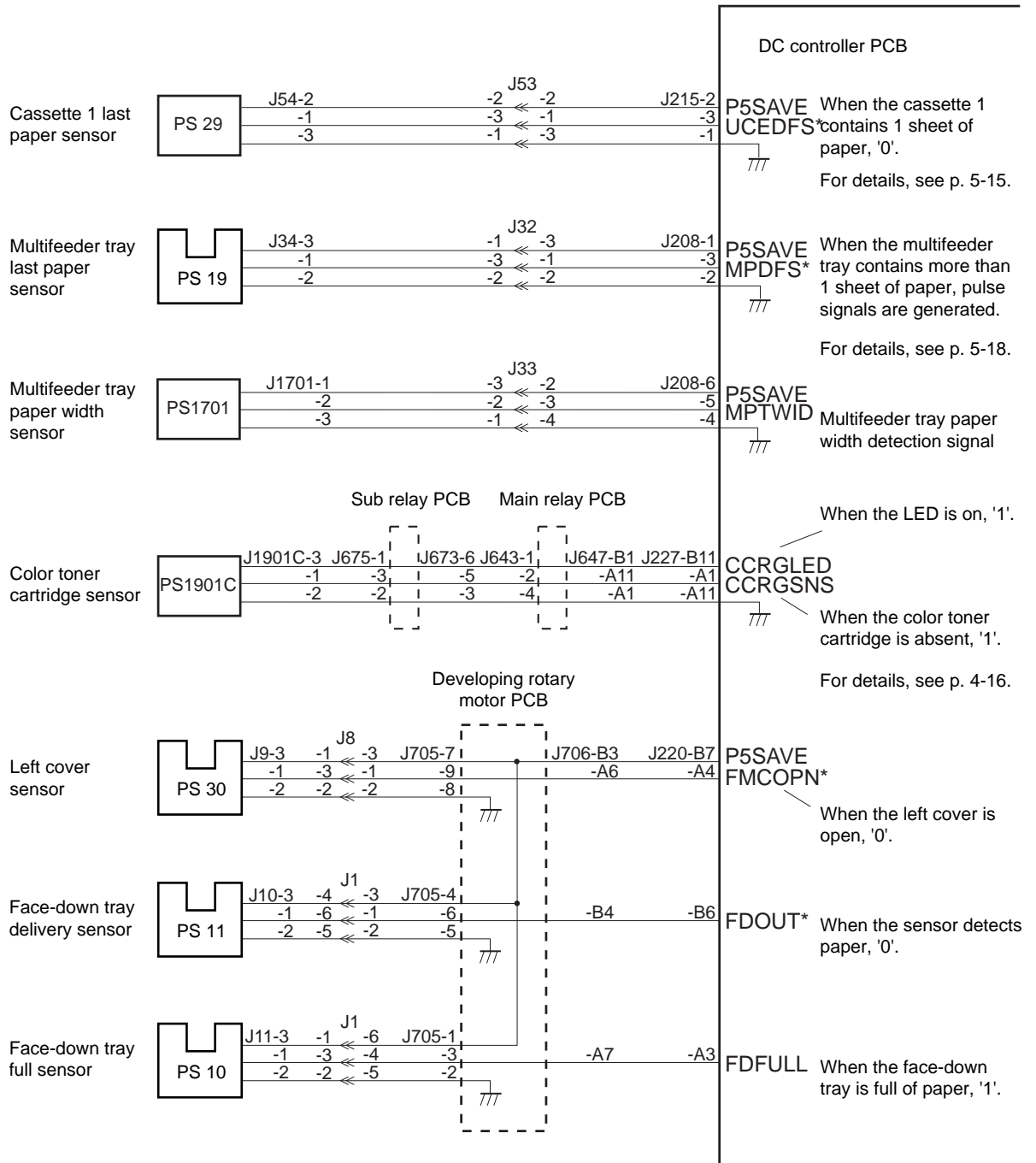

Figure 2-105

Inputs to and Outputs from the DC Controller PBC (4/10)

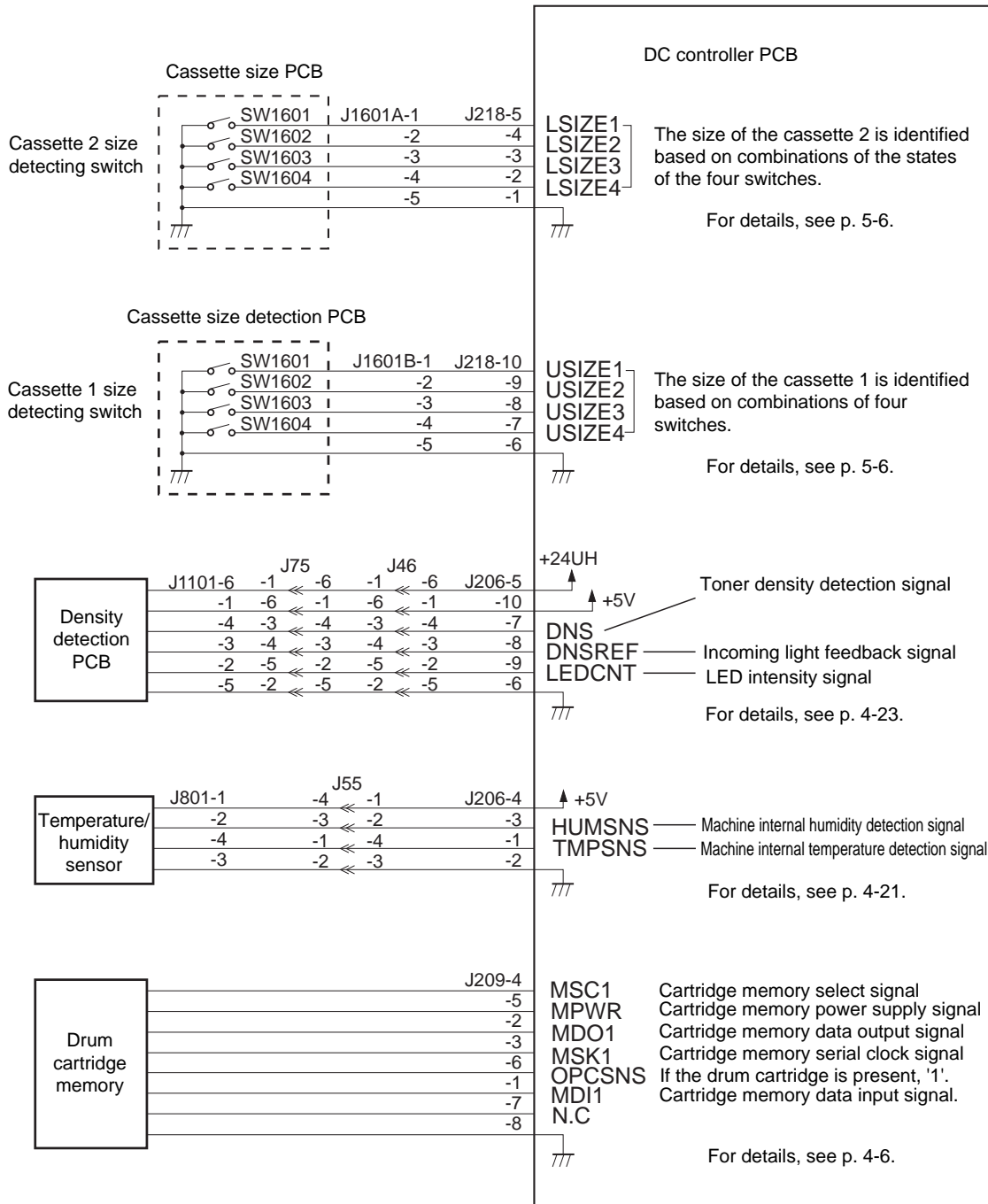

Figure 2-106

Inputs to and Outputs from the DC Controller PCB (5/10)

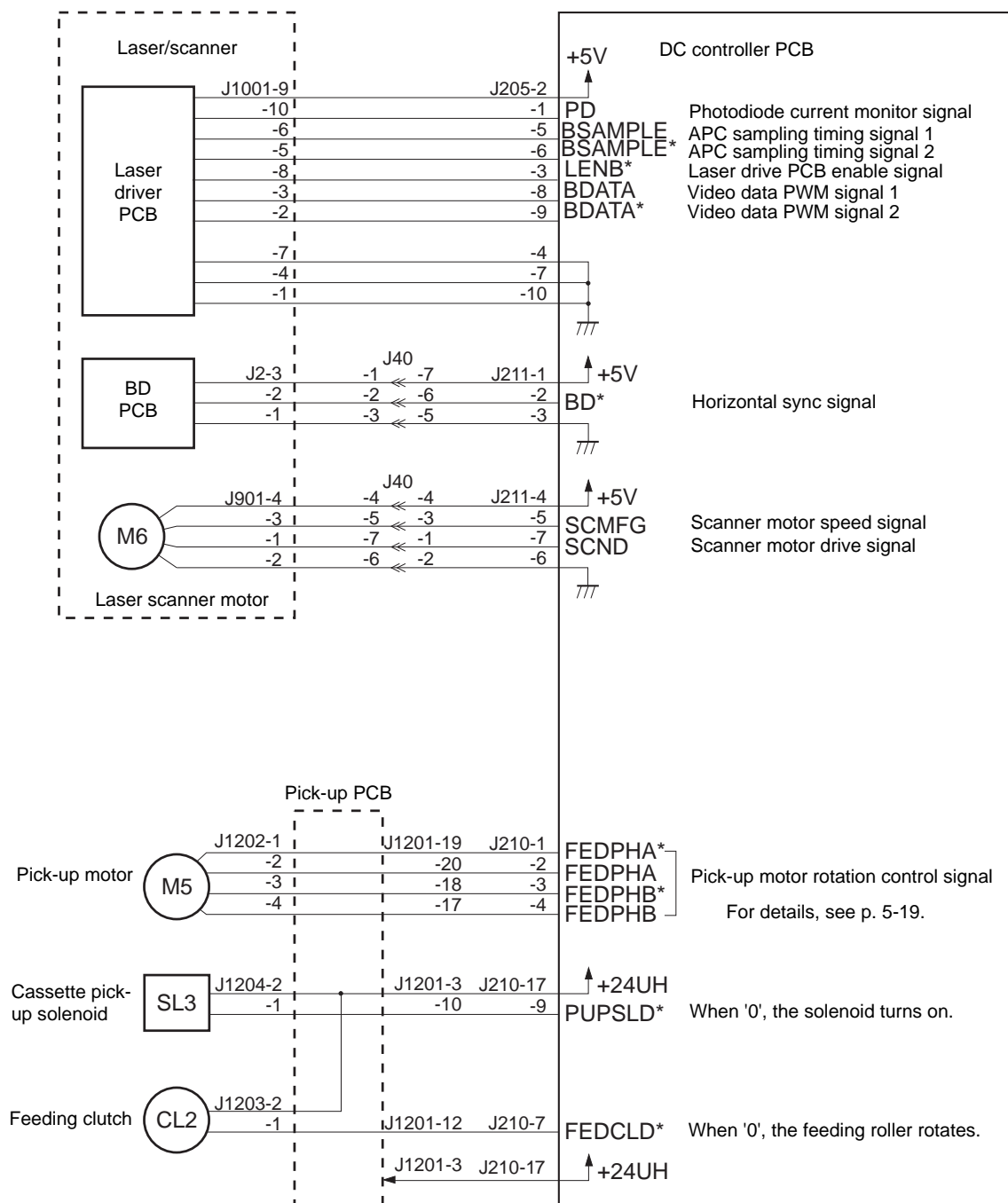

Figure 2-107

Inputs to and Outputs from the DC Controller PCB (6/10)

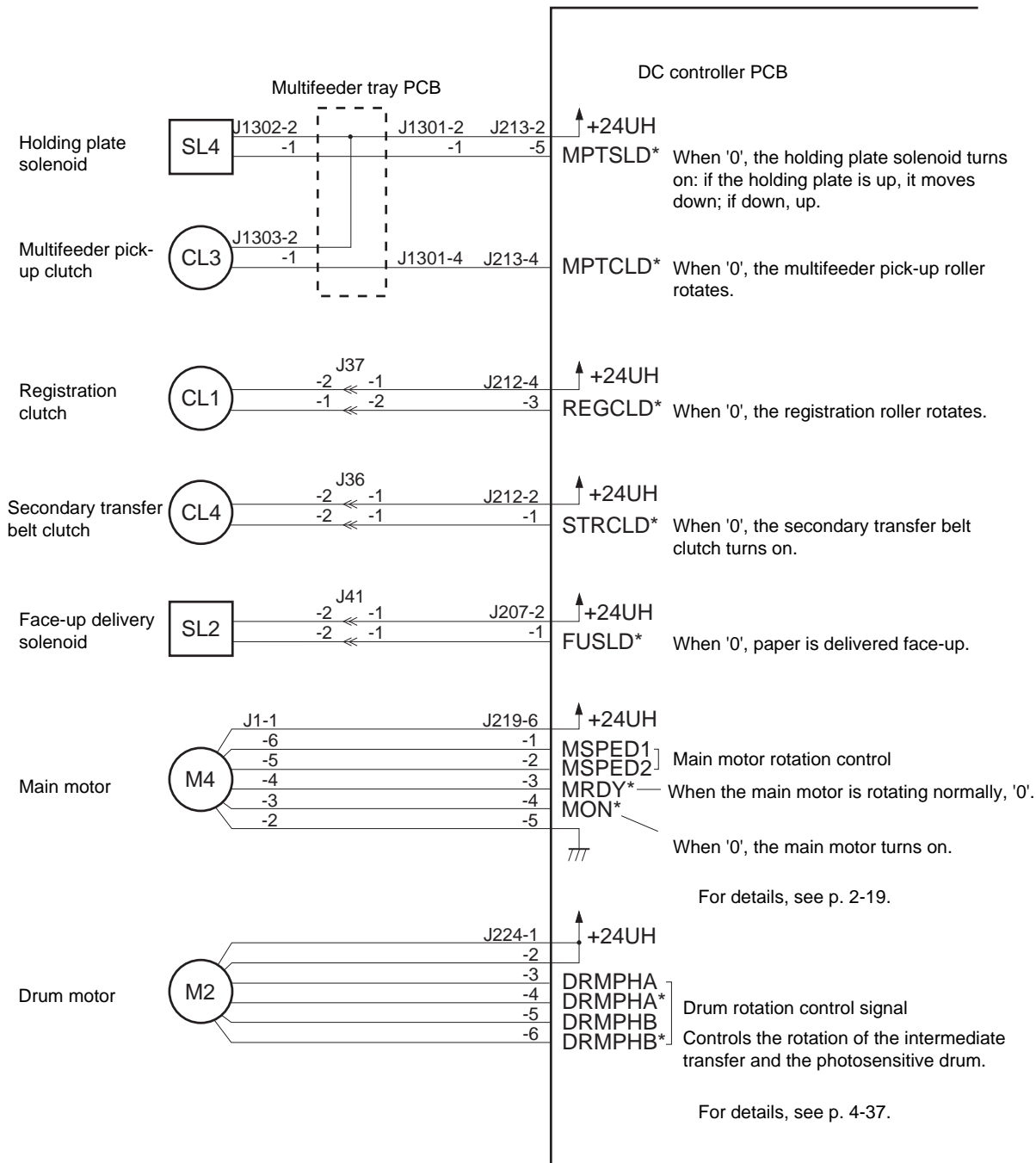

Figure 2-108

Inputs to and Outputs from the DC Controller PCB (7/10)

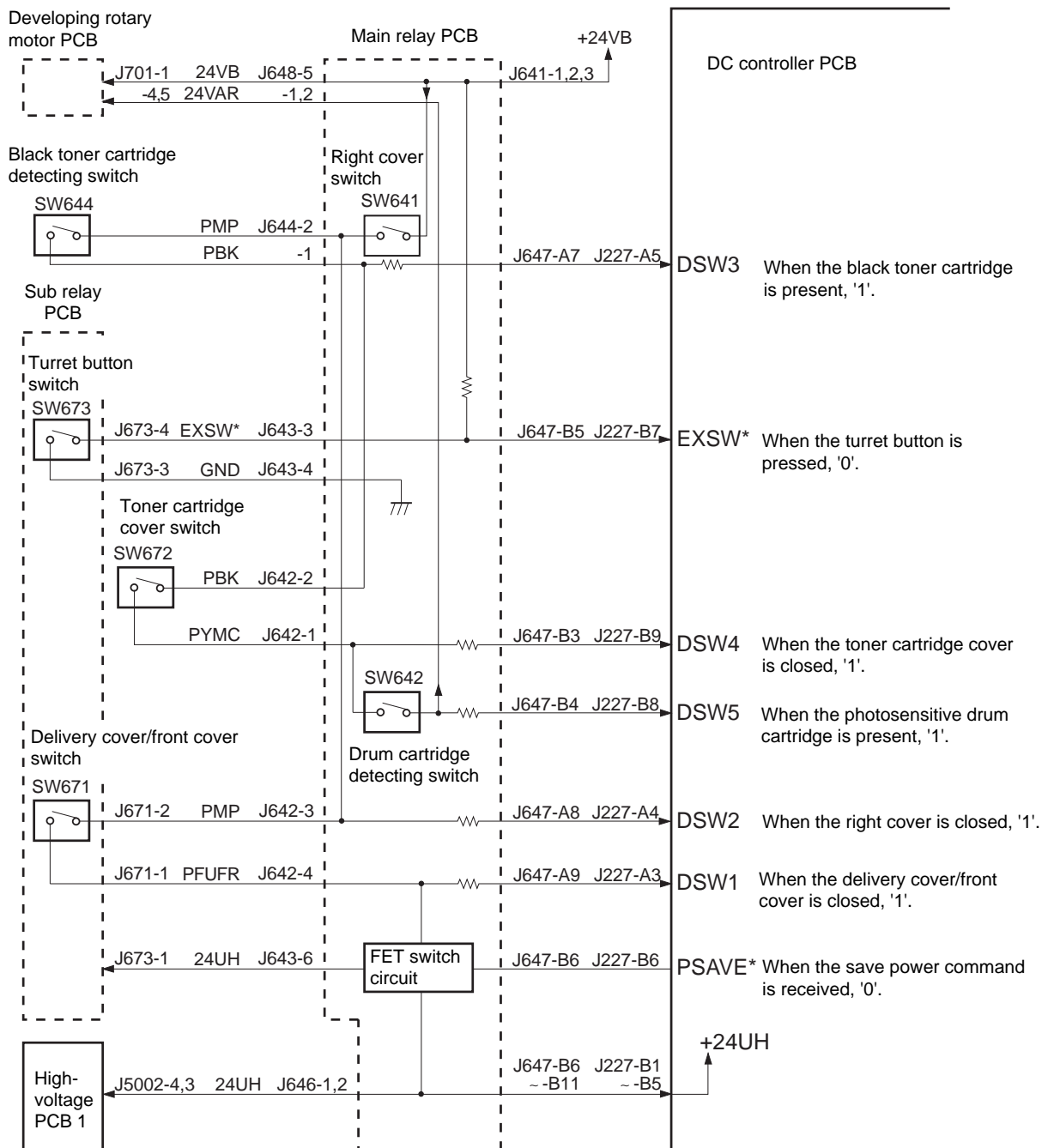

Figure 2-109

Inputs to and Outputs from the DC Controller PCB (8/10)

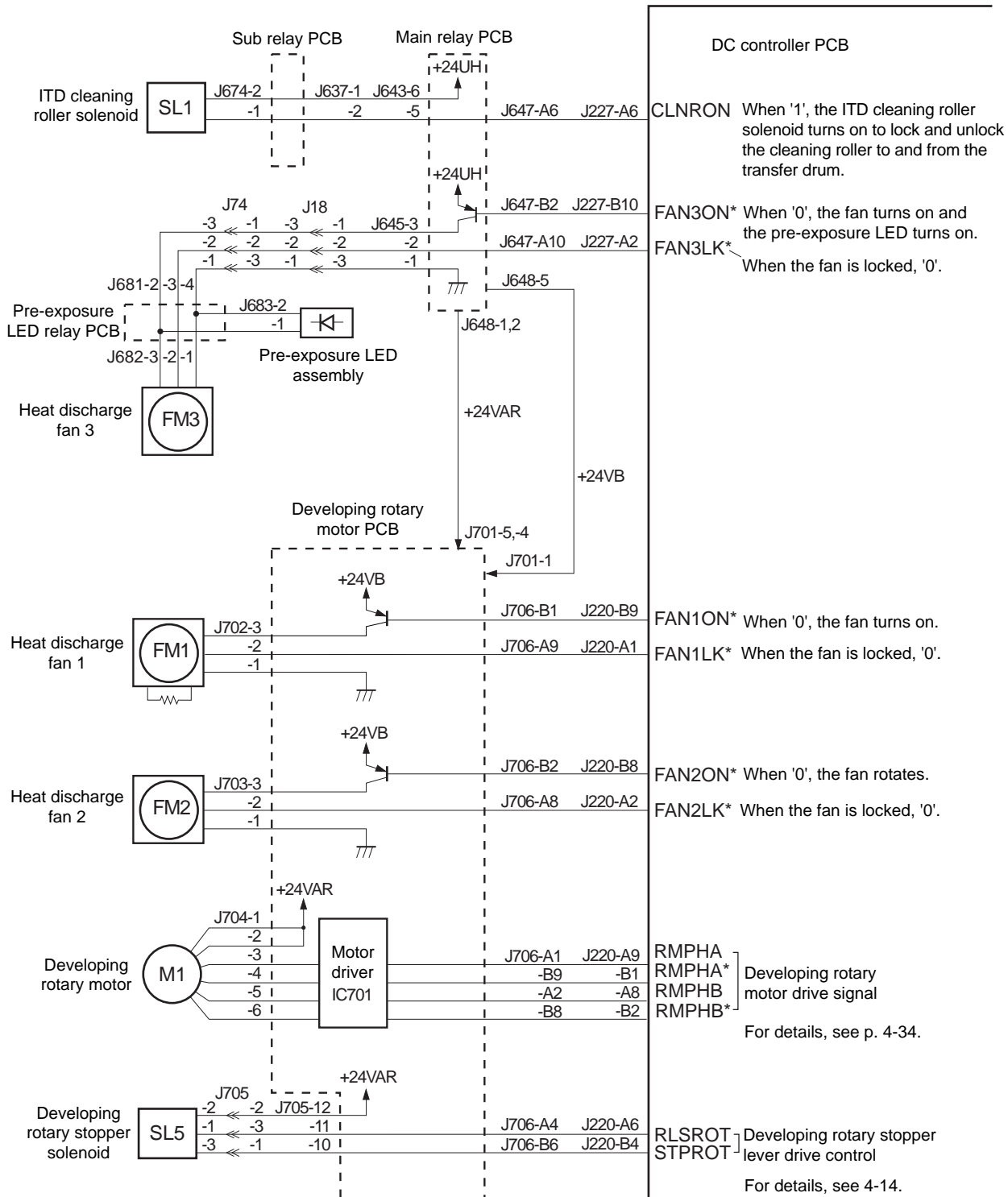

Figure 2-110

Inputs to and Outputs from the DC Control PCB (9/10)

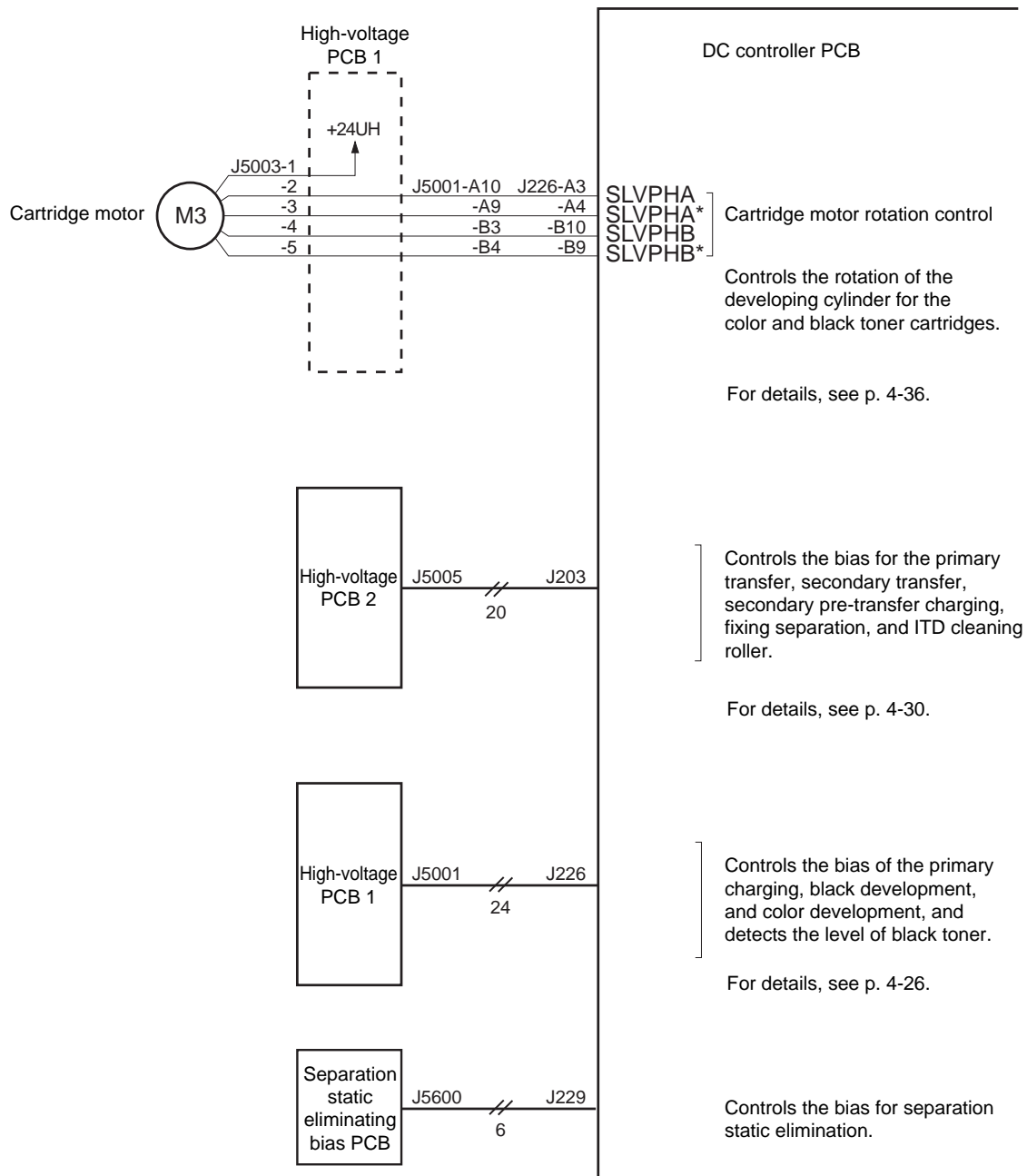
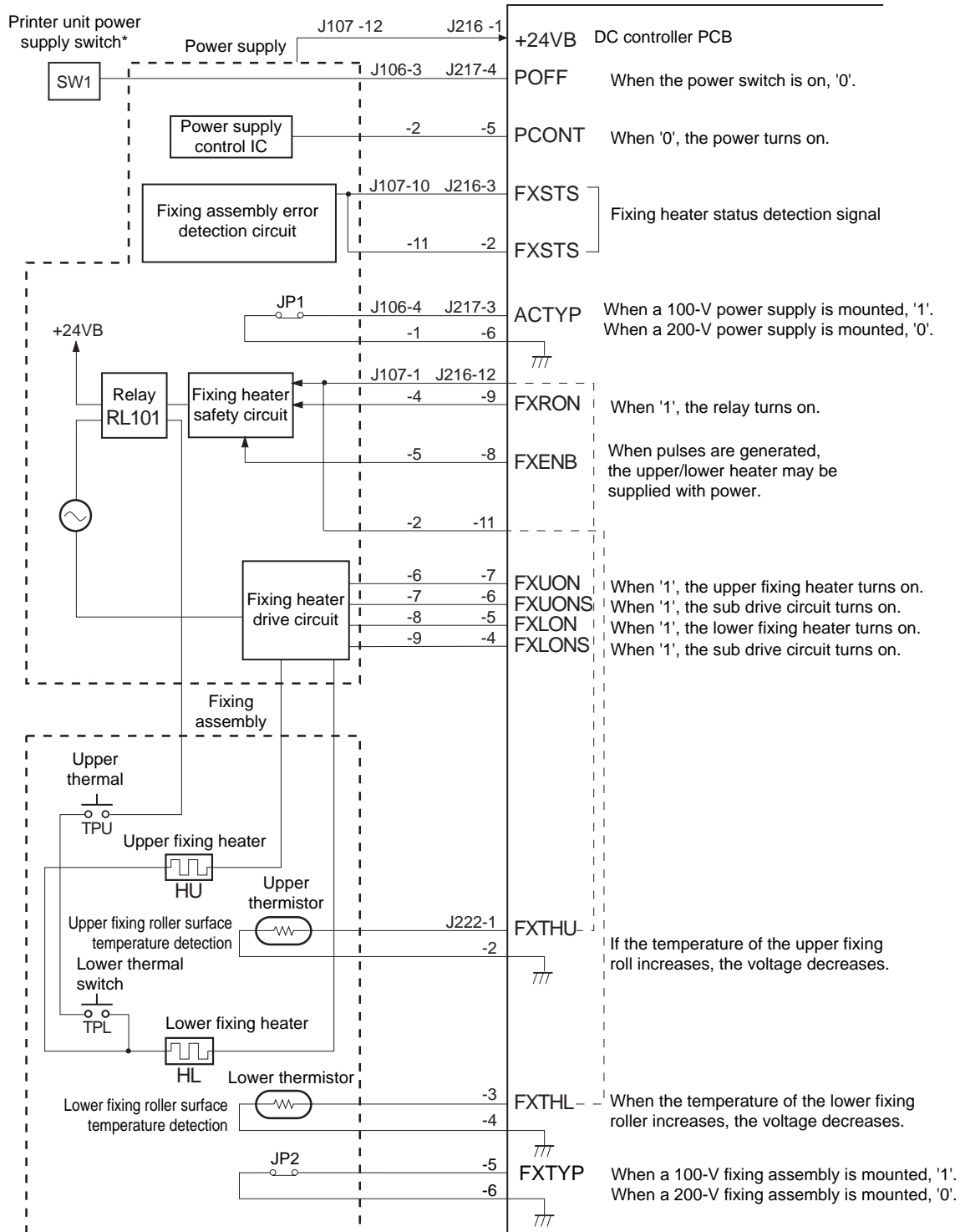

Figure 2-111

Inputs to and Outputs from the DC Controller PCB (10/10)



* When installing the reader unit, the printer unit power switch is turned on and blocked with a face plate; as such, it remains on at all times.

Figure 2-112

2. Inputs to and Outputs from the Duplexing Driver PCB

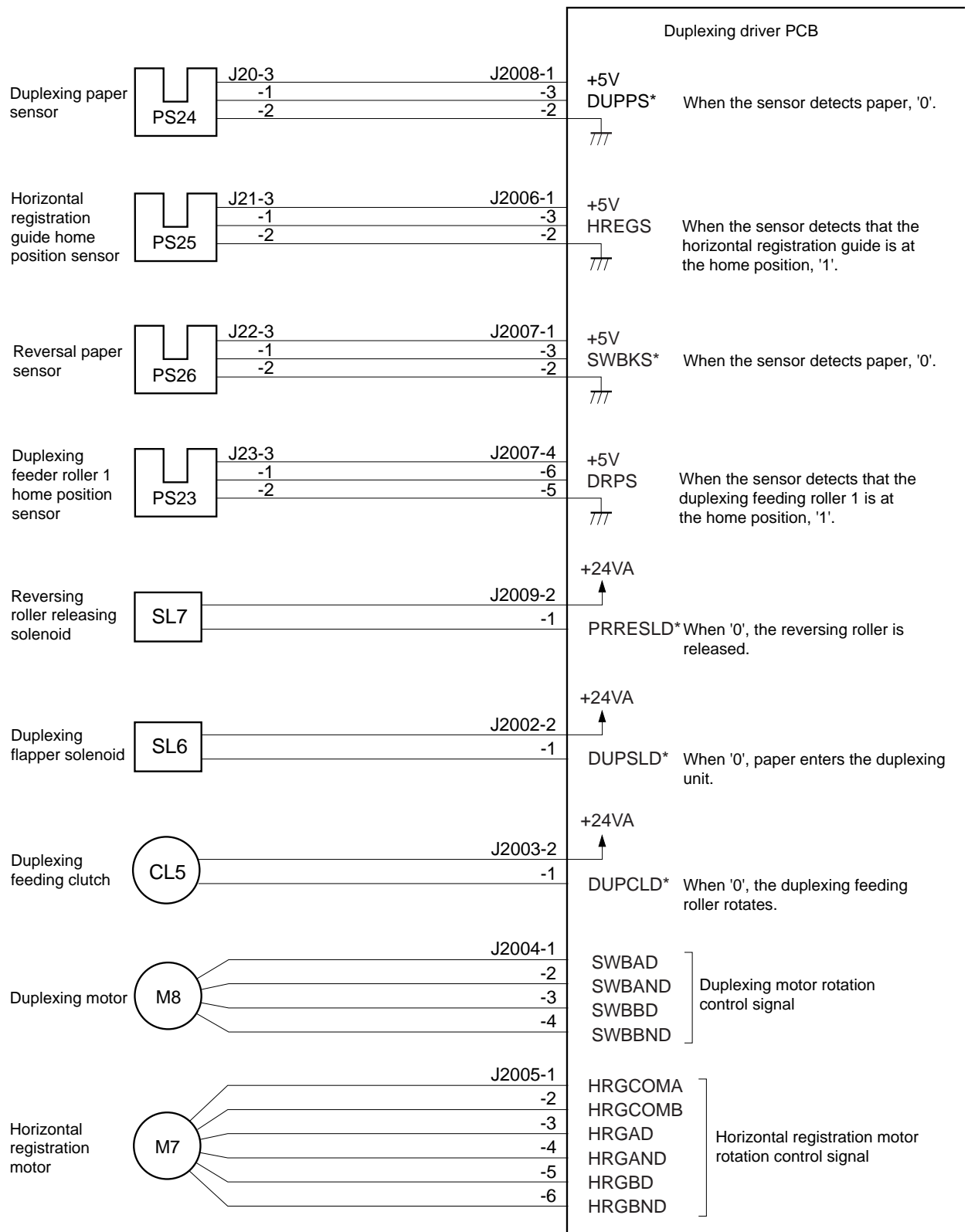
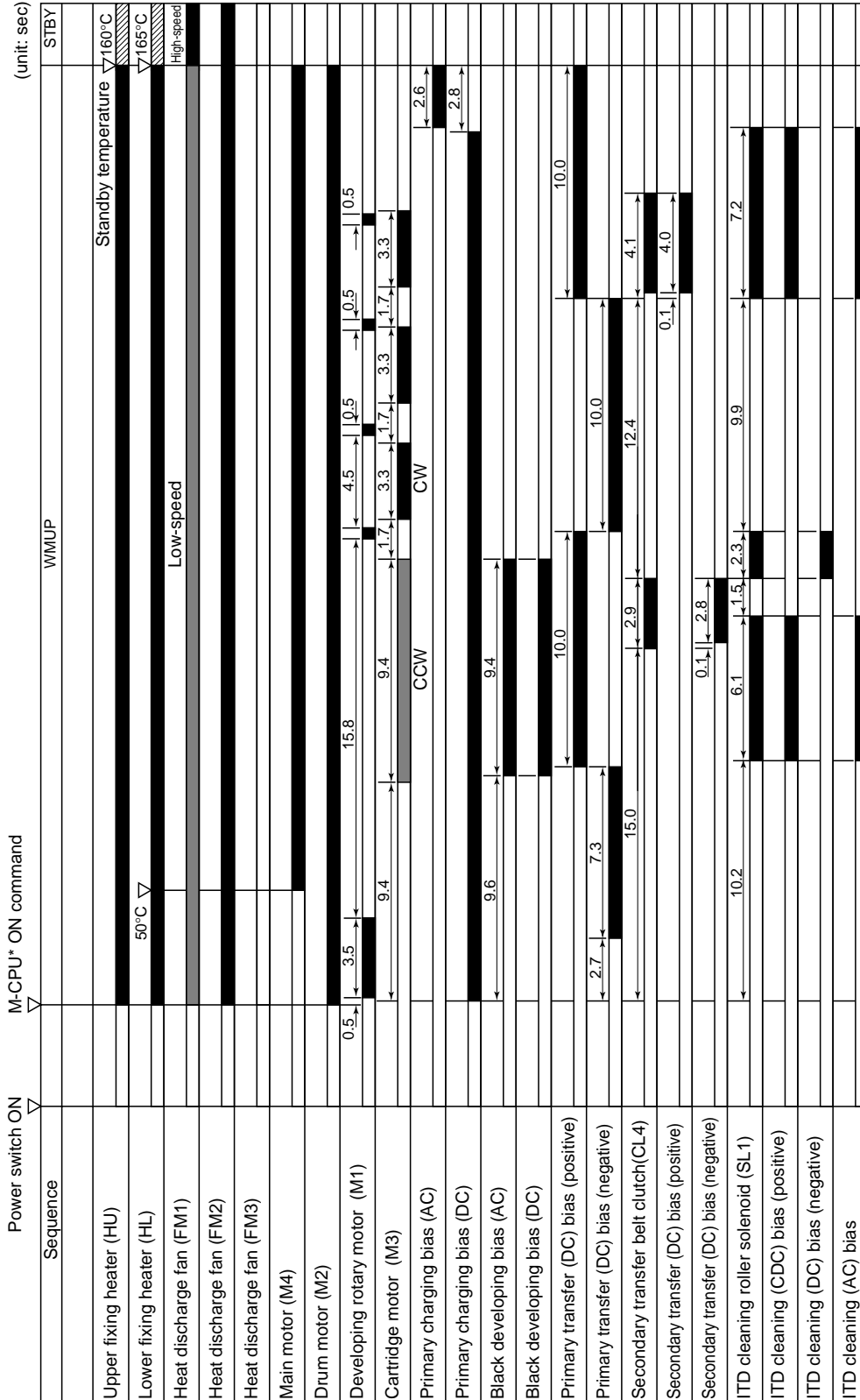

Figure 2-113

D. Basic Sequence of Operations (used as a printer)

1. Basic Sequence when the power switch is turned on.



* CPU on the DC controller PCB (p. 2-2).

Figure 2-114

Period		Purpose	Remarks
WMUP (warm-up)	From when the power switch is turned on to when the surface temperature of the upper fixing roller reaches 160°C and that of the lower fixing roller reaches 165°C.	To heat the fixing roller, thereby putting the printer unit into standby state.	During the period, the presence/absence of paper and toner cartridges is checked, and image stabilization correction control is performed.
STBY (standby)	From when WMUP ends to when the PRNT* signal is received; or, from when LSTR ends to when the printer board receives the PRNT signal or the power switch is turned off.	To control the fixing roller to the target temperature so that printing may start as soon as the PRNT* signal is received.	

Table 2-101

Reference:

For the sequence used to make prints when the reader unit is installed, see the Reader Unit Service Manual.

2. Basic Sequence of Operations for Printing

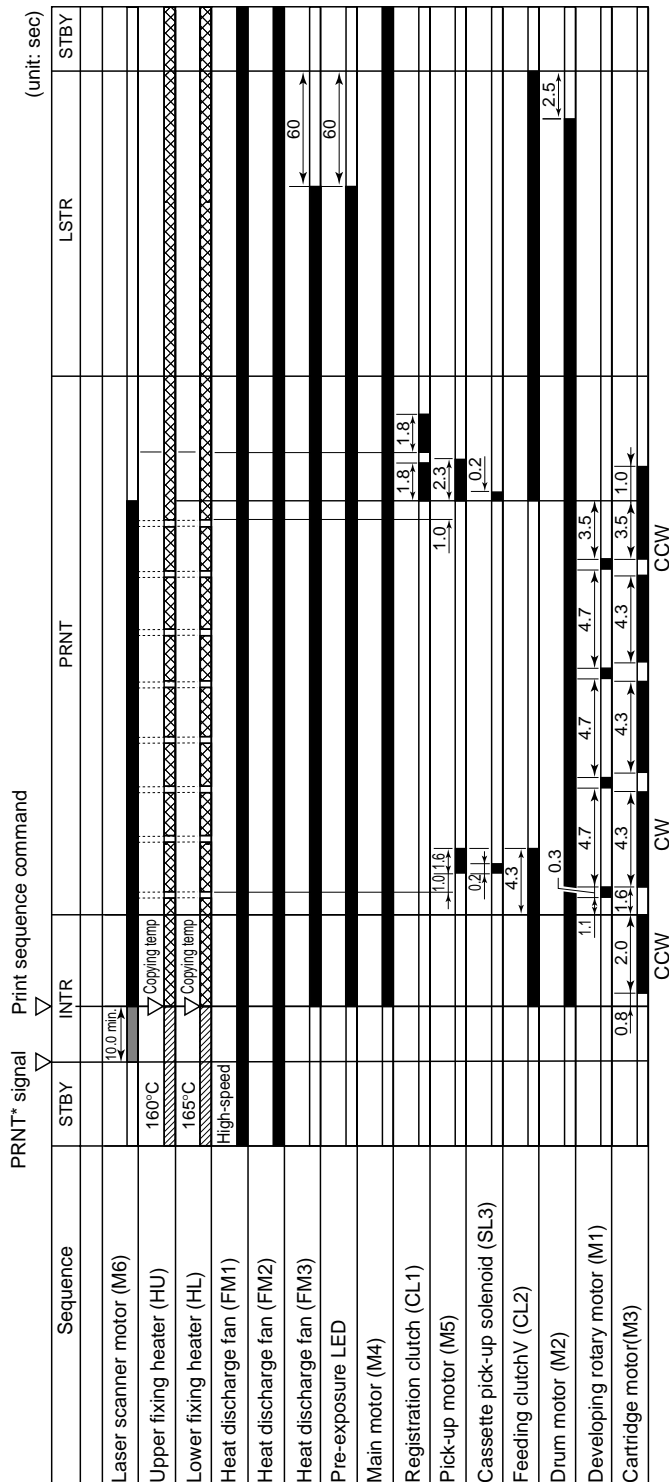

Figure 2-115 (A4/LTR, 2 prints, 4-color, cassette 1)

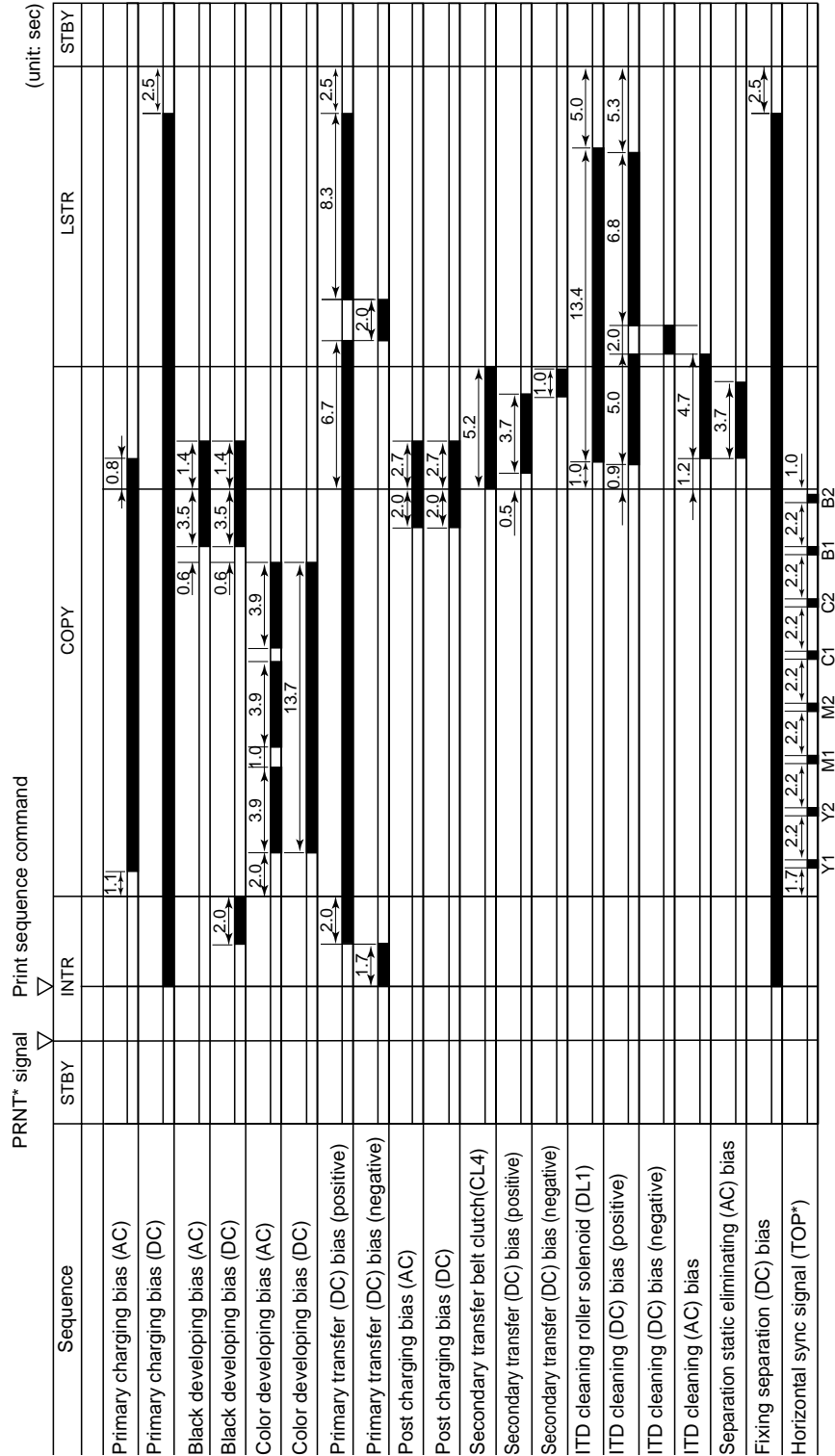

Figure 2-116 (A4/LTR, 2 prints, 4-color, Direct, cassette 1)

Period		Purpose	Remarks
INTR (initial rotation)	From when the PRNT* signal arrives from the printer board to when the Bk toner cartridge is ready for development and the cartridge motor stops.	To stabilize the sensitivity of the photosensitive drum in preparation for printing. Also, to prepare for development by toner cartridges.	
PRINT (print)	From when initial rotation ends to when paper reaches the registration roller after the end of primary transfer.	To form an image on the photosensitive drum based on VDO*0 through 7 from the video controller; then, to turn it into a visible image with toner and to transfer it onto the intermediate transfer drum.	
LSTR	From when the registration roller starts to rotate to when paper is picked up once again and the main motor stops.	To fully discharge the paper after secondary transfer and fixing. Also, to execute ITD cleaning.	ITD cleaning is executed for each print. (Cleaning is executed also during PRINT in continuous printing mode.)

Table 2-102

Reference:

For the sequence used to make prints when the reader unit is installed, see the Reader Unit Service Manual.

E. Controlling the Main Motor

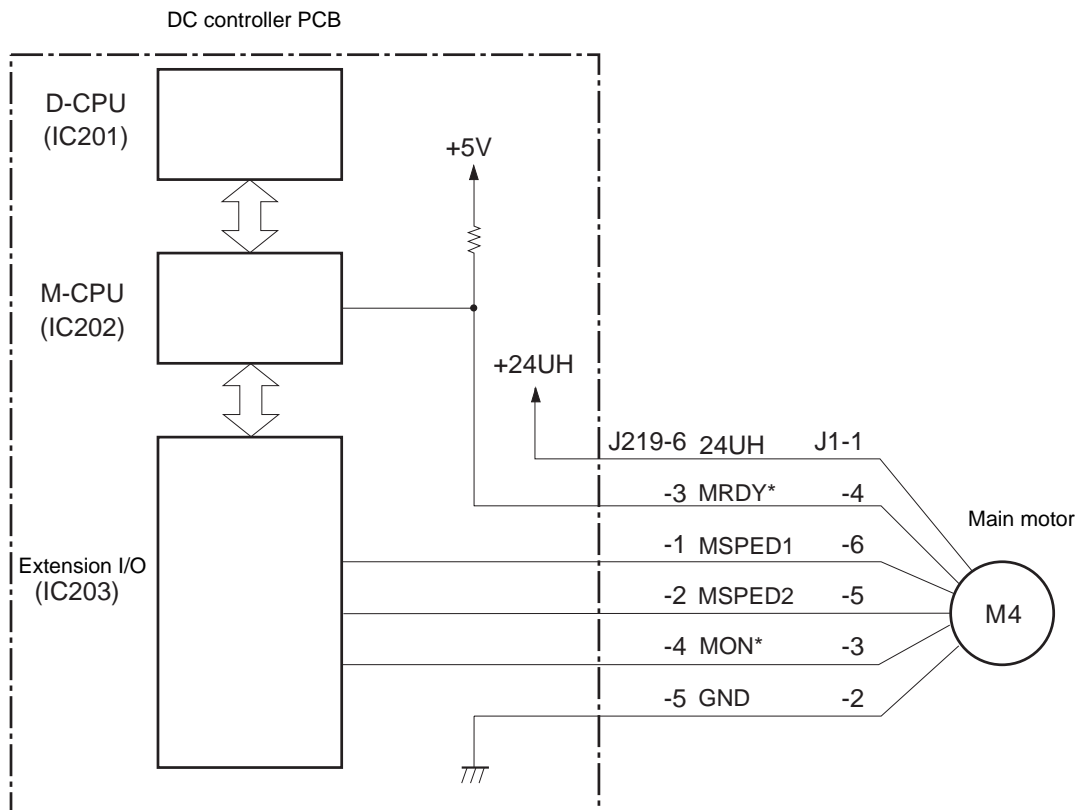

Figure 2-117

The main motor is a 3-phase 8-pole DC brushless motor. The main motor is controlled by an M-CPU (IC202) by way of an extension I/O, and it serves to drive the pickup-, feeding-, fixing-, and delivery-related rollers and the secondary transfer belt/ITD cleaning roller cams.

When the print sequence command*1 is received from the D-CPU (IC201), the M-CPU (IC202) causes the main motor drive signal (MON*) to go '0' by way of the extension I/O (IC203) to rotate the main motor.

The main motor causes the main motor ready signal (MRDY*) to go '0' when it reaches a specific speed.

The motor is switched to either of three speeds in response to combinations of main motor speed switch signals (MSPED1, MSPED2); i.e., normal, 1/4 speed (transparency mode), and 1/3 speed (thick paper mode).

Table 2-103 shows the relationship between speed and combinations of MSPED1 and MSPED2.

	MSPED1	MSPED1
Normal mode (normal rotation)	0	0
Transparency mode (1/4 speed)	1	0
Thick paper mode (1/3 speed)	0	1
At rest	1	1

Table 2-103

In the event of the following (main motor error), the D-CPU communicates the fact to the printer board*2:

- 1.MRDY* does not go '0' 2.5 sec after the main motor starts to rotate.*3
- 2.MRDY* goes '1' for 2.5 sec or more after MRDY* has gone '0' once.*4

- *1 Copy Start key ON command (when making copies with the reader unit installed).
- *2 Reader controller PCB (when making copies with the reader unit installed).
- *3 Indicates 'E010' on the control panel.
- *4 Indicates 'E011' on the control panel.

CHAPTER 3

LASER EXPOSURE SYSTEM

This chapter provides descriptions on the machine's laser exposure operations, functions of each operation, relationships between electrical and mechanical systems, and timing at which each associated part is turned on.

I.	OUTLINE.....	3-1	III.	LASER SCANNER MOTOR.....	3-9
II.	LASER CONTROL CIRCUIT	3-3	A.	Controlling the Laser Scanner Motor	3-9
A.	Outline.....	3-3	IV.	FAULT IN THE LASER SCANNER	3-11
B.	Image Signal Processing	3-5	V.	DISASSEMBLY/ASSEMBLY	3-12
C.	Controlling the Laser Intensity	3-6	A.	Printer Unit External Covers	3-13
D.	Horizontal Sync Control	3-7	B.	Door Switch Actuator	3-22
E.	Controlling the Laser Diode Emission	3-8	C.	Laser/Scanner Assembly	3-25

I. OUTLINE

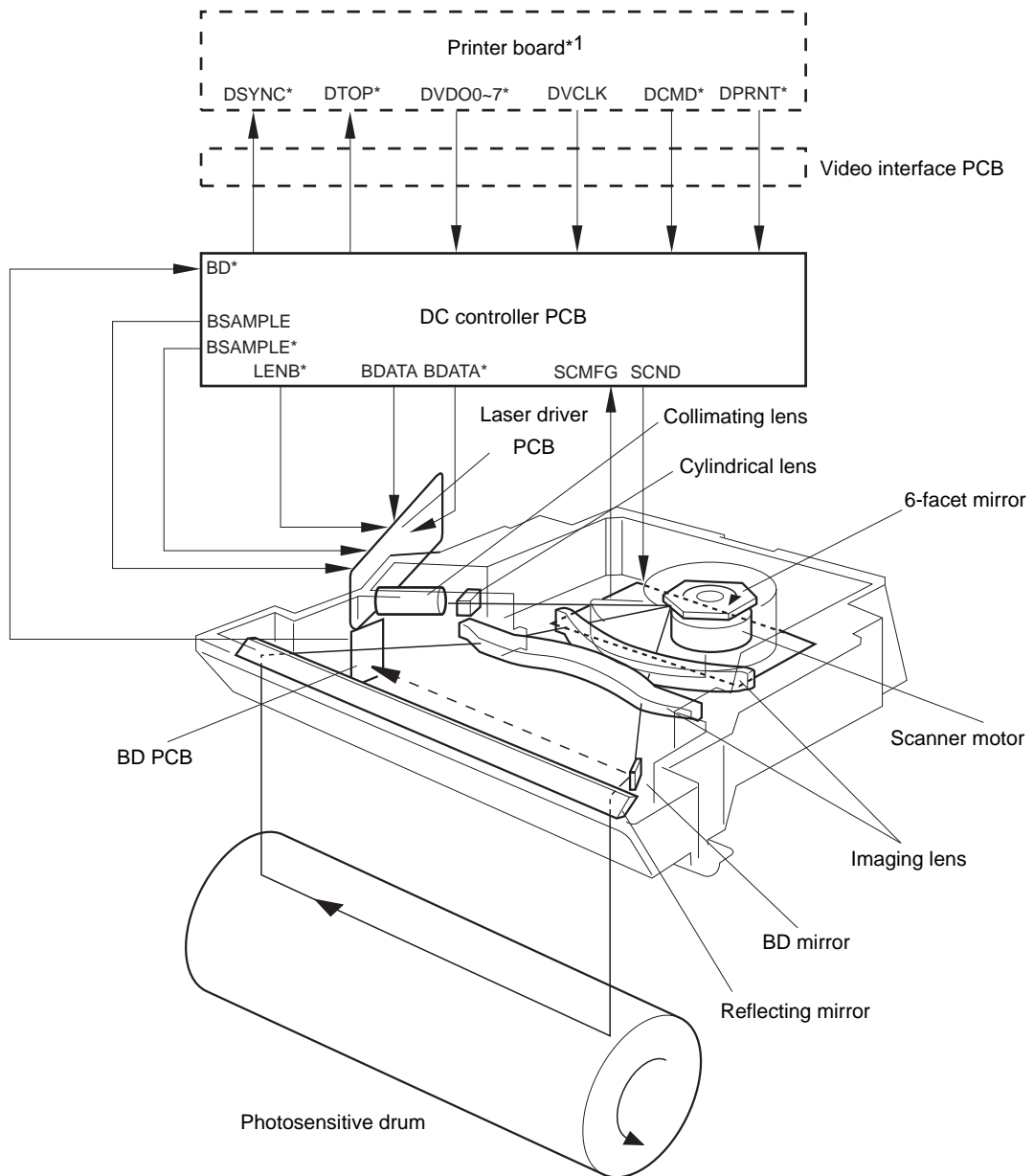

Figure 3-101

*1 Reader controller PCB (when making prints with the reader unit installed).

The video signals (DVDO0 through 7*) from the printer board1 are converted into PWM video data signals (VDATA*); subjected to pulse width modulation on the DC controller PCB; then, they are converted into two sets of low-voltage differential signals (Note) with suppressed radiation noise, and are sent to the laser driver PCB.

The signals are further converted into laser drive signals on the laser driver PCB (internal signals of the laser/scanner assembly) used to turn on and off the laser diode, thereby generating a laser beam.

The modulated laser beam is turned into a parallel beam by means of a collimating lens and a cylindrical lens, and is directed to a 6-facet mirror rotating at a specific speed.

When reflected by the 6-facet mirror, the laser beam moves through an imaging lens and a reflecting mirror arranged in front of the 6-facet mirror to focus on the photosensitive drum.

The 6-faceted mirror rotates at a specific speed, enabling the laser beam to scan the surface of the photosensitive drum at a specific speed.

An image takes shape on the surface of the photosensitive drum as the drum rotates at a specific speed and, while at the same time, as the laser beam scans its surface at a specific speed.

Note:**Low Voltage Differential Signal**

The machine's PWM modulation circuit is on the DC controller PCB, requiring PWM-modulated laser drive signals to move through a cable for turning on and off the laser. If PWM-modulated laser drive signals were sent over a cable as they are, the noise radiating from the cable would affect the PCBs on the way. To prevent such a problem, the signals are processed to suppress amplitude. The printer unit generates two sets of signals (differential signals) to avoid a decrease in the noise margin, otherwise caused by low amplitude.

II. LASER CONTROL CIRCUIT

A. Outline

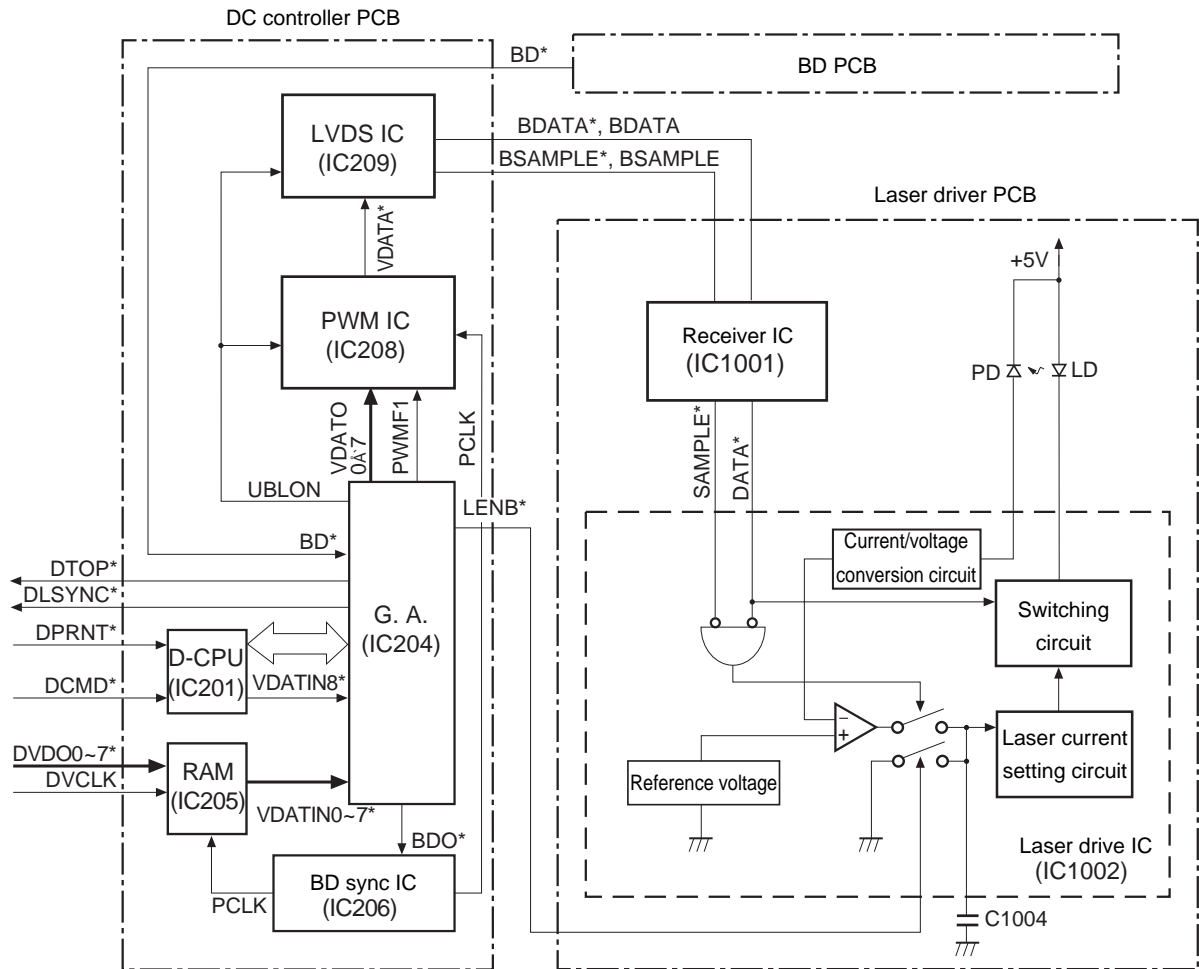

Figure 3-201

The laser control circuit serves to control the laser mechanism according to the video signals (DVDO0 through 7*) from the printer board. The GA (IC204) on the DC controller PCB generates video data signals (VDATO0 through 7) and image mode setting signal (PWMF1) using video signals from the printer board *1 and the image mode switch signals (VDATIN8*) coming by way of the D-CPU (IC201).

The PWM IC (IC208) generates PWM modulation signals (VDATA*; PWM video signals); then, it sends two sets of laser drive signals (DATA*, BDATA) through the LVDS IC (IC209) to the laser driver PCB. The receiver (IC1001) on the laser driver PCB demodulates these two sets of signals to generate laser drive signals (DATA*) for the laser drive IC (IC1002).

When the APC sampling timing signal (SAMPLE*) is '1' and the image enable signal (LENB*) is '0', the laser drive IC turns on the laser diode in response to the laser drive signal (DATA*).

*1 Reader controller PCB (when making prints with the reader unit installed).

B. Image Signal Processing

The printer board sends video signals (VDO0 through 7*; C, M, Y, and Bk, each representing 8-bit data) and CMD* signals (image mode switching command) to the DC controller PCB. The D-CPU (IC201) on the DC controller PCB is used to generate image mode switch signals (VDATIN8*; Note) from CMD* signals.

The video signals (DVDO0 through 7*) sent by the printer board *1 to the DC controller PCB are directed to a RAM (IC205; line memory) and then to a gate array (IC204).

The video signals (DVDO0 through 7*) are subjected to image masking processing (p. 3-3) in IC204, and are sent to the PWM IC (IC208) as video data signals (VDATO0 through 7). At the same time, the image mode switch signals (VDATIN8*) are moved through the gate array (IC204), and are sent to the PWM IC (IC208) as PWMF1 signals.

Then, the video data signals (VDATO0 through 7) are turned into PWM demodulation signals (VDATA*; PWM video data signals) combined with PWMF1 signals (selected image mode) by the PWM IC (IC208); they are then sent to the laser driver PCB of the laser scanner as two sets of laser drive signals (BDATA*, BDATA) by way of the LVDS IC (IC209).

When making full-color copies, the foregoing operations are performed for Y, M, C, and BK in sequence to form images. When making mono-color copies, on the other hand, these operations are performed for one of the four colors.

At the end, the laser driver PCB is ready to send the laser drive signals (DATA*; result of demodulation by the receiver (IC1001) to the laser drive IC (IC1002).

*1 Reader controller PCB (when making copies with the reader unit installed).

Note:

Switching the Image Mode

The printer unit switches image mode (text or halftone) in response to the image mode switch command from the reader controller PCB so as to enable the best images in text and halftone areas.

C. Controlling the Laser Intensity

The auto intensity control mechanism (APC) of the laser diode is controlled by the laser drive IC (IC1002) to ensure that the laser diode emits light at a specific intensity.

The DC controller PCB causes the APC sampling timing signal (SAMPLE*) to go '0' for each line of image data. The image enable signal (LENB*) and the laser drive signal (DATA*) go '0', and the laser drive IC (IC1002) enters sampling mode (Note 1). As a result, the laser diode (LD) turns on, and its intensity is detected by the photodiode (PD).

The intensity detected by the photodiode is fed back to the comparator through the current/voltage conversion circuit, and is compared against the reference voltage selected in the laser drive circuit IC to control the laser current sent to the laser diode.

At the end of a specific period of time (end of unblanking), the SAMPLE* signal goes '1', and the printer unit enters hold/print mode (Note 2) to end forcing the laser diode (LD) to emit light. In response, the laser drive IC converts the controlled laser light into a voltage for retention in a capacitor (C1004).

The voltage retained by the capacitor (C1004) is cleared when the capacitor is discharged in response to the image enable signal (LENB*) going '1' at the end of each single line. (Note 3)

When video signals are received, the ELENB* signal goes '0', SAMPLE* signal goes '1', and DATA* signals are generated; the printer unit enters hold/print mode.

Table 3-201 shows the above relationship:

	Laser	LENB*	DATA*	SAMPLE*
APC sampling mode	On	L	L	L
Hold/print mode	On/Off	L	H/L	H
Clear mode	Off	H	—	—

Table 3-201

Note:

1. Sampling Mode

In APC control, when the LENB* signal is '0' and the SAMPLE* signal is '0' (i.e., the unblanking signal UBLON used to generate the SAMPLE* signal is generated by the GA), the DATA* signal is forced to go '0'.

2. Hold/Print Mode

In this mode, the laser intensity resulting from APC control is retained. When the SAMPLE* signal is '1' and the LENB* signal is '0', C1004 retains the laser intensity in the form of a voltage without regard to DATA* signals.

When video signals are received, the laser diode is turned on and off according to the DATA* signals.

3. Clear Mode

When the LENB8 signal is '1', the C1004 is discharged without regard to DATA signals* and SAMPLE* signals.

D. Horizontal Sync Control

The optical path for the laser beam is equipped with a small fixing mirror (BD mirror). The laser beam reaching the scan start position during the unblanking period is reflected by the BD mirror and directed to the BD PCB inside the laser/scanner assembly.

When the laser beam arrives, the BD PCB generates BD signals (BD*) for transmission to the GA (IC204) on the DC controller PCB. The GA uses the BD* signals to generate horizontal sync signals (LSYNC*), and sends them to the printer board.*¹

*¹ Reader controller PBC (when making prints with the reader unit installed).

E. Controlling the Laser Diode Emission

The laser drive circuit turns on and off the laser diode according to laser drive signals from the PWM IC when the image enable signal (LENB*) from the DC controller PCB is '0' and the APC sampling timing signal (SAMPLE*) is '1'.

The GA (IC204) puts video signals (DVDO0 through 7*) through masking processing for left/right and top/down directions for transmission to the PWM IC.

The paper size is communicated to the D-CPU (IC201) by means of a paper size command coming from the cassette size detecting switch in the case of cassette pickup or from the printer board*1 in the case of multifeeper pickup.

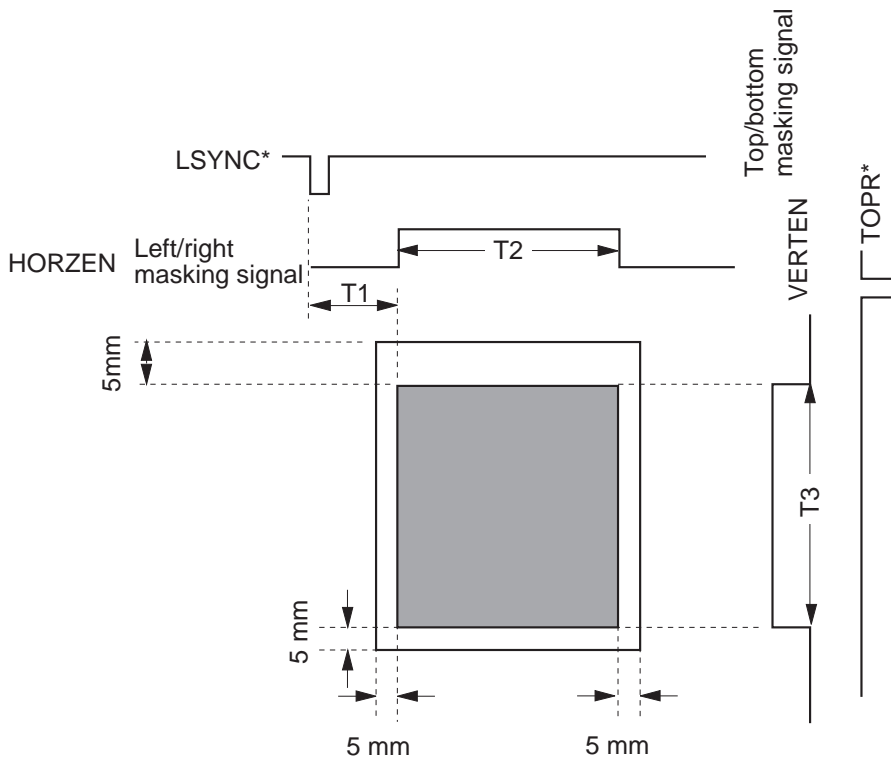

Figure 3-202

Note:

1. The laser beam is capable of writing within the shaded area.
2. T1 through T3 differ according to paper size.
3. If the paper size command from the printer board does not indicate a paper size when the multifeeper is used, the printer unit assumes T3 is 12x18.5 (maximum paper size) in the absence of data.

The multifeeper tray is equipped with a paper width sensor (PS1701) for detection of the width of paper.

The CPU identifies the size of paper in relation to the length of print paper detected by PS1 when the trailing edge of the paper moves past the registration paper sensor (PS1).

*1 Reader controller PCB (when making prints with the reader unit installed).

III. LASER SCANNER MOTOR

A. Controlling the Laser Scanner Motor

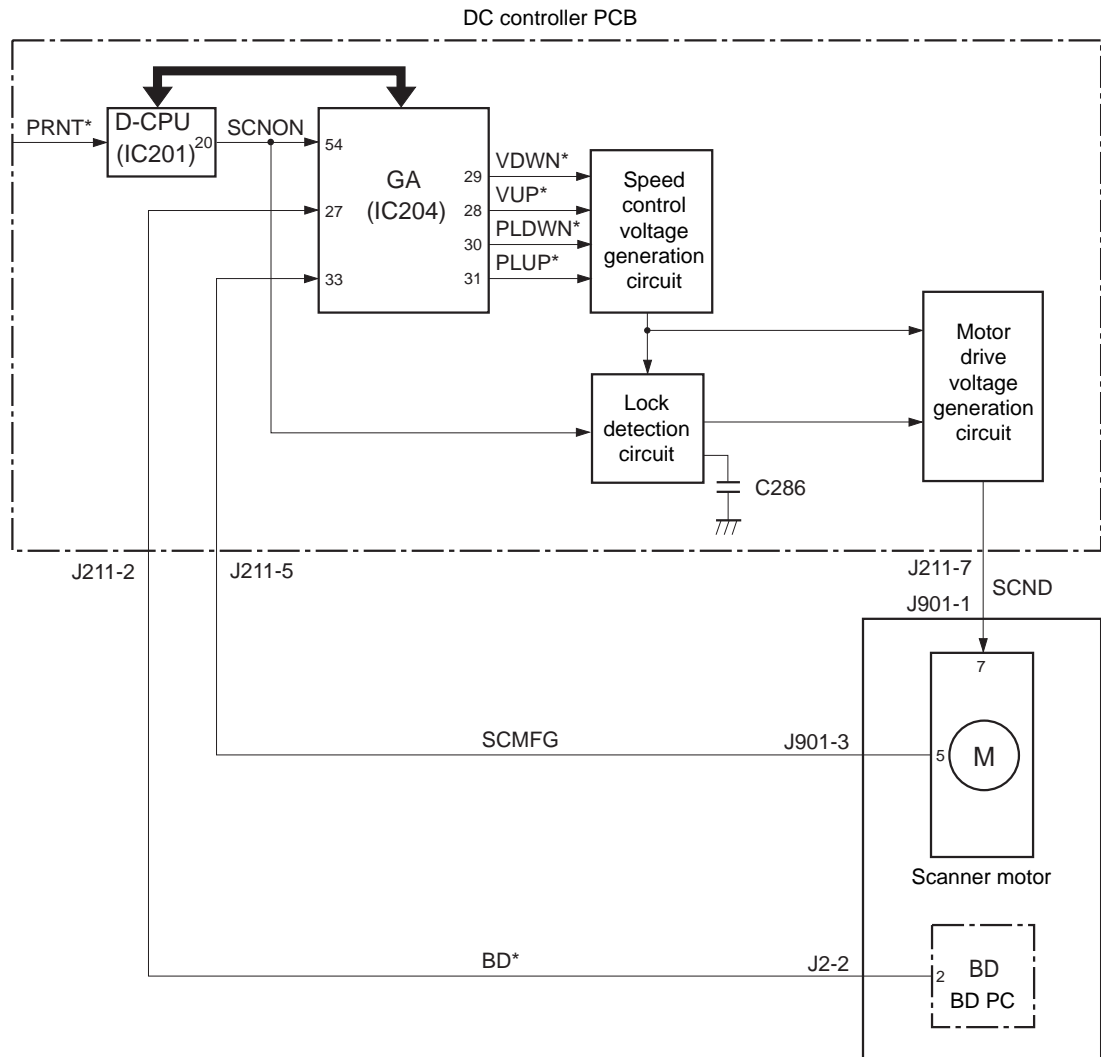

Figure 3-301

The machine's laser scanner motor is a 3-phase, 8-pole DC brushless motor.

The laser scanner motor driver circuit is in the GA (IC204), and is equipped with two control circuits, controlling speed and discrepancies in phase to ultimately control the rotation of the laser scanner motor.

The speed is controlled based on the laser scanner motor speed signal (SCMFG) from the laser scanner motor, while the phase is controlled using the BD signal. (See Note.)

When the printer unit is turned on and the PRNT* signal is sent to the D-CPU (PC201) on the DC controller PCB, the D-CPU sends the rough adjustment acceleration signal (VUP*) to the speed control voltage generation circuit through the GA (IC204).

As a result, the motor drive voltage generation circuit generates the laser scanner motor drive signal (SCND) to rotate the laser scanner motor. The laser scanner motor feeds the SCMFG signal to the GA (feedback) to communicate its revolution, and the GA controls the VUP8 signal and the VDWN8 signal until a specific revolution is reached.

When the laser scanner motor reaches a specific revolution, the GA switches from the SCMFG signal to the BD* signal as the target of detection to start control of the laser scanner motor (including phase control).

The GA adds the fine adjustment acceleration signal (PLUP*) and the fine adjustment deceleration signal (PLDWN*) to the rough adjustment signal, and controls the fine adjustment signal (PLUP*, PLDWN*) until the phases match based on the BD* signal from the BD PCB, consequently causing the laser scanner motor to rotate at a specific speed.

When a specific revolution is reached, the GA writes BDRDY to the internal register to enable the D-CPU (IC201) to judge whether the laser scanner motor is rotating at a specific speed by monitoring the data.

Note: _____

The printer unit deposits four color toners on a single sheet of paper, requiring that the laser write start position be accurate. To ensure correct laser rotation (revolution), the printer unit controls the motor including its phase.

IV. FAULT IN THE LASER SCANNER

The laser scanner is checked for a fault by the D-CPU (IC201) by monitoring the BD* signal by way of the GA. It then stops the laser scanner motor if the cycle of the BD* signals fails to be a specific cycle (Note 1) or the cycle of the BD* signals deviates from a specific cycle (Note 2). At the same time, the D-CPU forces the laser to turn on to monitor the photodiode inside the scanner unit to identify a fault in the laser or the laser scanner motor; at the end, it communicates the result to the printer board*1. If BDERR is detected momentarily, the D-CPU identifies it as a BD error.

If the motor drive signal is continuously applied while the laser scanner motor is locked, damage to the motor can occur. To prevent such a problem, the printer unit is equipped with a lock detection circuit which forces off the motor as an additional protective mechanism.

The lock detection circuit assumes that the scanner is locked if the VUP* signal and the PLUP* signal continue for 5 sec after the laser scanner motor starts to rotate (during initial drive); upon detection, the laser scanner motor drive signal (SCND) is made to go '0' and, at the same time, charges are stored in the error memory capacitor (C286). Once charges are stored in the capacitor, the SCND signal will be cut off, stopping the laser scanner motor drive. (See Note 3.)

*1 Reader controller PCB (when making prints with the reader unit installed).

Note:



1. If the cycle of the BD signals fails to be a specific cycle 7 sec after the scanner motor starts to rotate (during initial drive).
 2. If BDRDY is "false" for 2.5 sec or more after the scanner motor has reached its specific speed (after BDRDY has been written to the internal register of the GA).
 3. The error memory capacitor (C286) is a protective mechanism preventing continuous application of the scanner motor drive signal. The error of the lock detection circuit is initialized in 10 sec or so. The SCNON signal also forces the capacitor to discharge, thereby initializing the error.
-

Reference:

- E100: Fault in the laser.
 E110: Fault in the laser scanner motor, or a BD fault.
-

V. DISASSEMBLY/ASSEMBLY

Make sure of the following when disassembling or assembling the machine:

1.  When the printer unit power switch is turned off, the fans will operate for about 30 min to cool the machine (so as to prevent caking of toner). Be sure to perform either of the following in addition to disconnecting the power plug:
 - Wait for 30 min after turning off the printer unit power switch; or
 - Turn off the printer unit power switch, and remove the fixing assembly of the printer unit.
2. Assemble the parts by reversing the steps used to disassemble them, unless otherwise mentioned.
3. Identify the screws by type (length, diameter) and location.
4. Do not leave out the toothed washer that comes with one of the mounting screws on the rear cover to protect against static electricity.
5. Do not leave out the washer that comes with the screw used for the grounding wire and the varistor to ensure electrical continuity.
6. Do not operate the machine with any of its parts removed, unless otherwise mentioned.
7.  Do not throw a toner cartridge into fire. It may explode.
8. Keep any toner cartridge in a protective cover whenever it has been taken out of the printer unit for disassembly/assembly work even for a short time.
9. Remove the cartridge and the intermediate transfer drum before disassembly/assembly work or moving the machine.
10. Touch the machine's metal section before starting the work to discharge the build-up of static electricity so as to prevent static damage before handling any PCBs.
11. To slide out the printer unit from the rack (if the reader unit is also mounted to the rack), pull halfway out the two side pins at the bottom of the rack (middle pin orientation *), and then remove the printer unit fixing member from the left of the printer unit. Be sure also to remove the printer side power cord and the interface cable.

A. Printer Unit External Covers

- ① Front cover
- ② Front right cover
- ③ Upper cover
- ④ Side cover
- ⑤ Rear cover
- ⑥ Upper left cover
- ⑦ Delivery assembly cover
- ⑧ Right cover
- ⑨ Multifeder tray

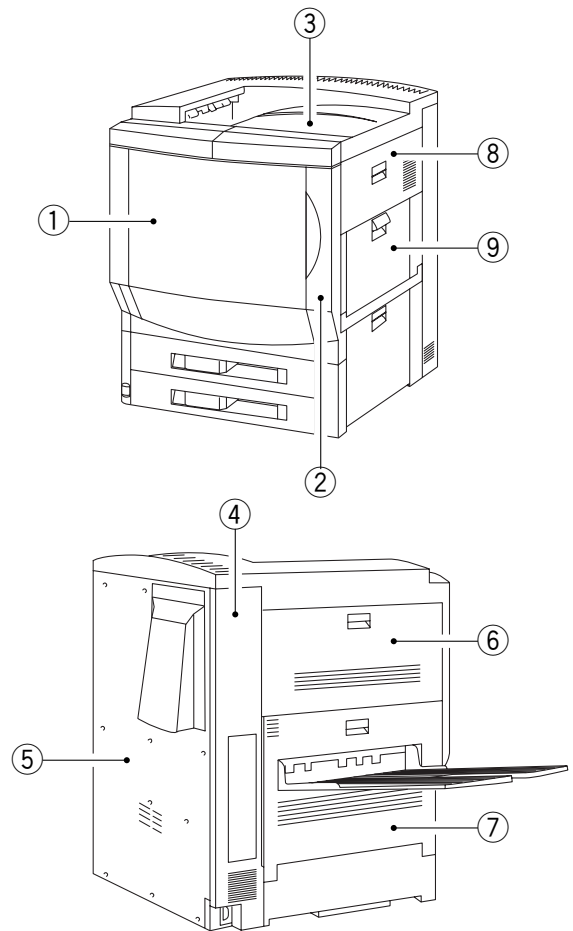

Figure 3-501

- ⑩ Inside cover 1
- ⑪ Inside cover 2
- ⑫ Inside cover 3
- ⑬ Inside cover 4

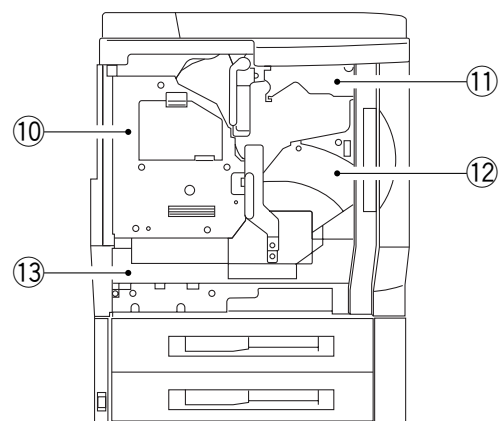
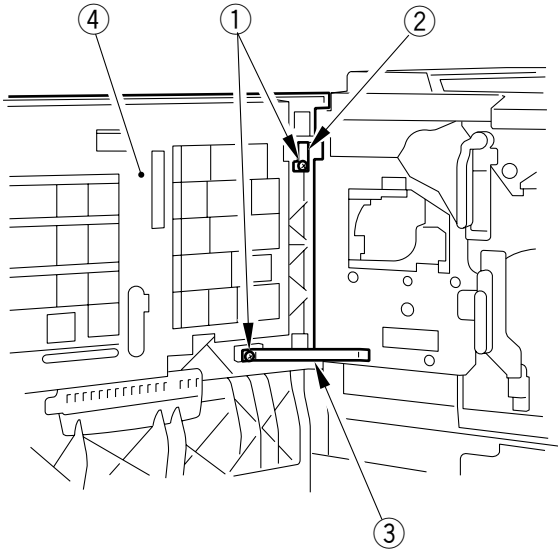

Figure 3-502

1. Front Cover

- 1) Open the front cover.
- 2) Remove the two screws, and remove the metal fixing and the strap; then, lift the front cover to detach.



- ① Screws
- ② Strap
- ③ Metal fixing
- ④ Front cover

Figure 3-503

2. Front Right Cover

- 1) Open the front cover.
- 2) Remove the screw, and detach the front right cover.

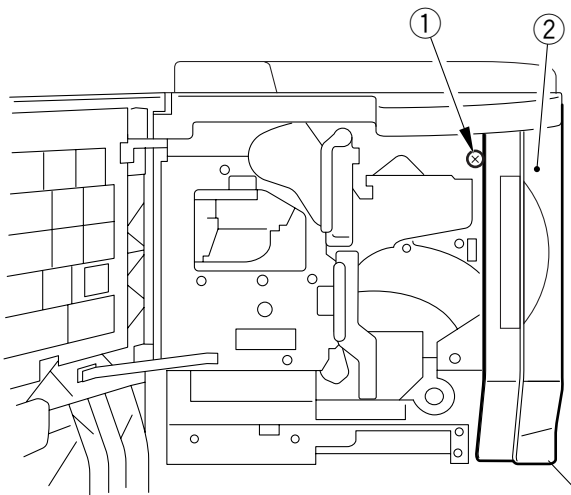

- ① Screw
- ② Front right cover

Figure 3-504

Caution:

When mounting the front right cover to the printer unit, be sure to check to make sure that the two claws under the front right cover and the hook on the right of the front right cover are fitted in the printer unit. Otherwise, the front cover will not close.

3. Upper Cover

- 1) Remove the front right cover by following the steps on p. 3-14.
- 2) Open the left cover, and loosen the two screws.

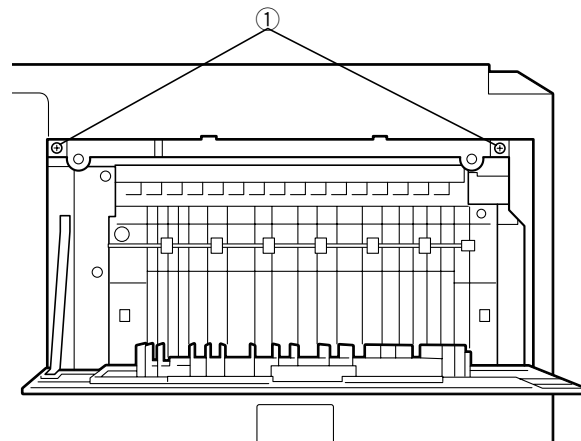

- ① Screws
- ② Upper cover

Figure 3-505

- 3) Open the right cover, and loosen the two screws.

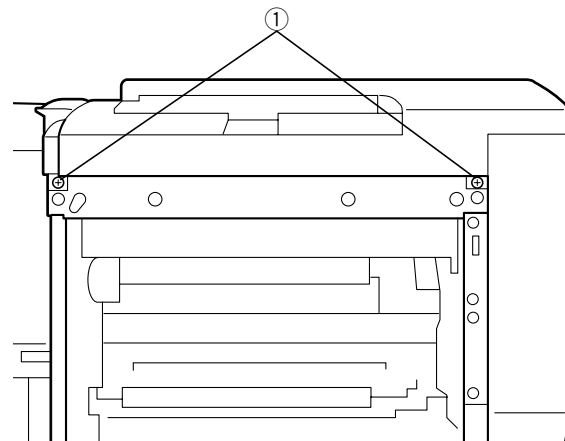

- ① Screws

Figure 3-506

- 4) Lift the upper cover, and disconnect the connector; then, detach the upper cover.

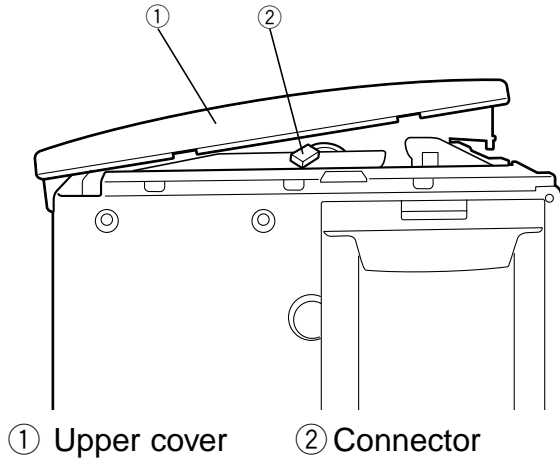
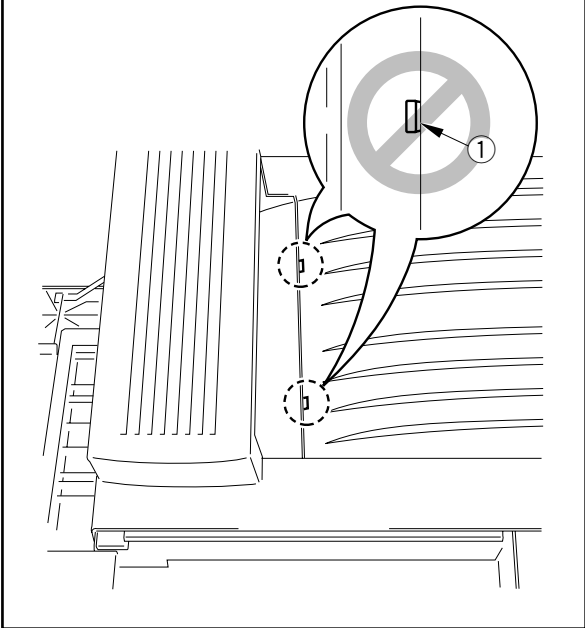

Figure 3-507

Caution:
Put the connector ② under the edge saddle of the printer unit when mounting the upper cover.

Caution:
When mounting the upper cover to the printer unit, check to make sure that the two claws ① of the upper cover are fitted in the delivery assembly cover.



4. Side Cover

- 1) If the PS/PCL board is installed, loosen and remove the screws.
- 2) Open the left cover.
- 3) Remove the strap and the four screws.

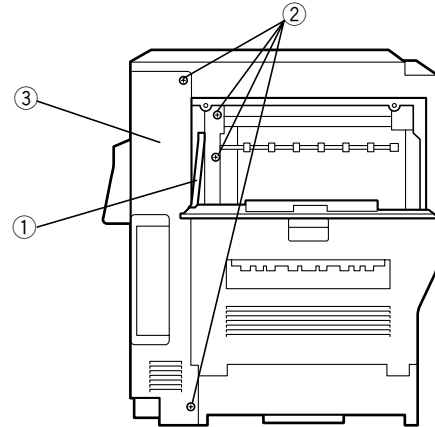

- ① Strap
- ② Screws
- ③ Side cover

Figure 3-508

- 4) Remove the seven screws, and detach the side cover.

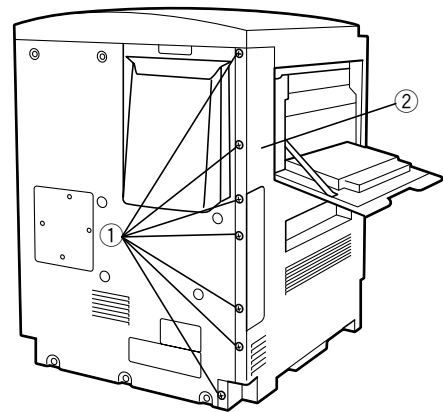

- ① Screws
- ② Side cover

Figure 3-509

5. Rear Cover

- 1) Remove the side cover by following the steps on p. 3-15.
- 2) While opening the right cover 2, remove the screw, and detach the right cover 3.

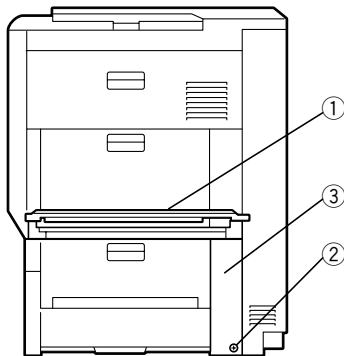

- ① Right cover 2
- ② Screw
- ③ Right cover 3

Figure 3-510

- 3) Remove the two screws.

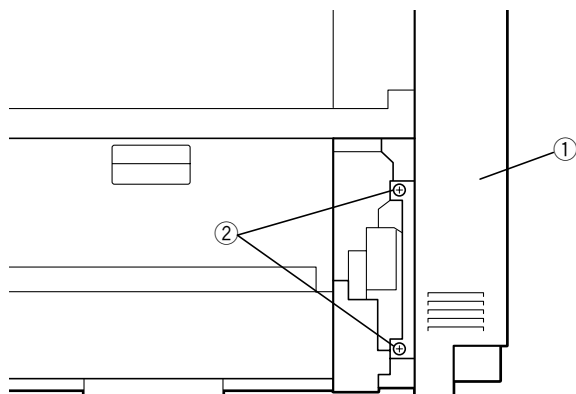

- ① Rear cover
- ② Screws

Figure 3-511

- 4) Open the right cover, and remove the three screws.

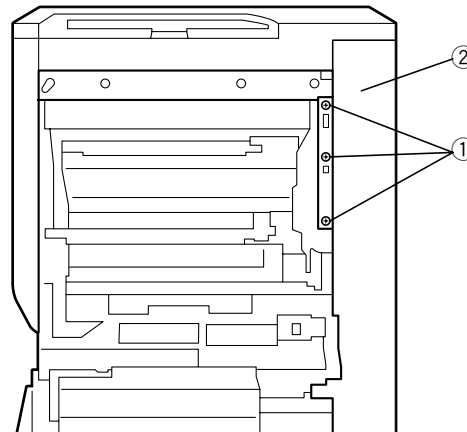

- ① Screws
- ② Rear cover

Figure 3-512

- 5) Lift the open/close lever to open the fan cover.

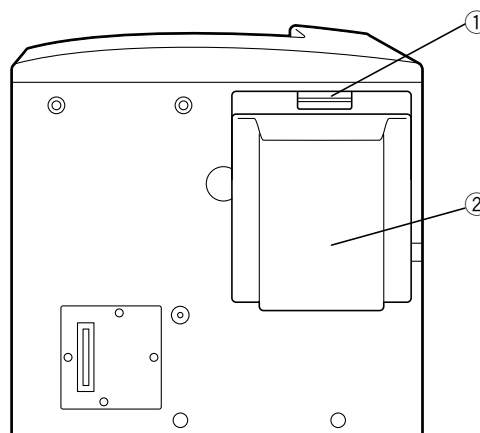

- ① Open/close lever
- ② Fan cover

Figure 3-513

- 6) Remove the screw, and detach the sub cover.

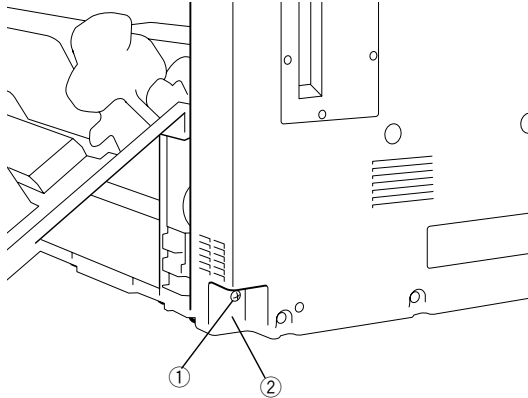

- ① Screw ② Sub cover

Figure 3-514

6. Left Cover

- 1) Open the left cover, and remove the strap.

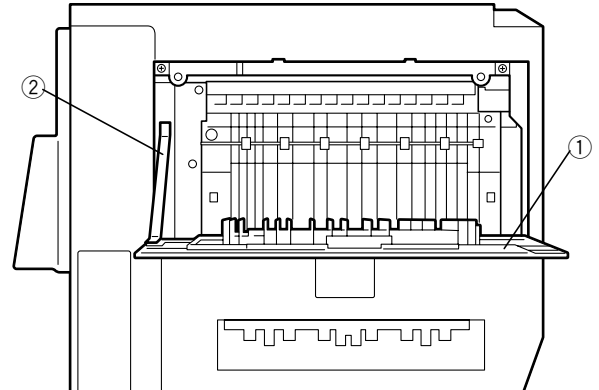

- ① Left cover ② Strap

Figure 3-516

- 7) Remove the 13 screws, and detach the rear cover together with the fan cover by sliding them up.

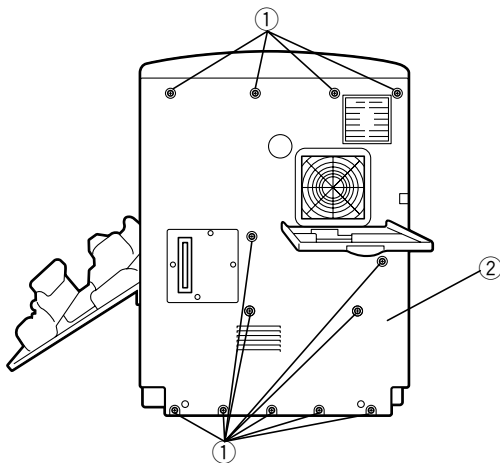

- ① Screws ② Rear cover

Figure 3-515

- 2) Remove the two screws, and detach the left cover.

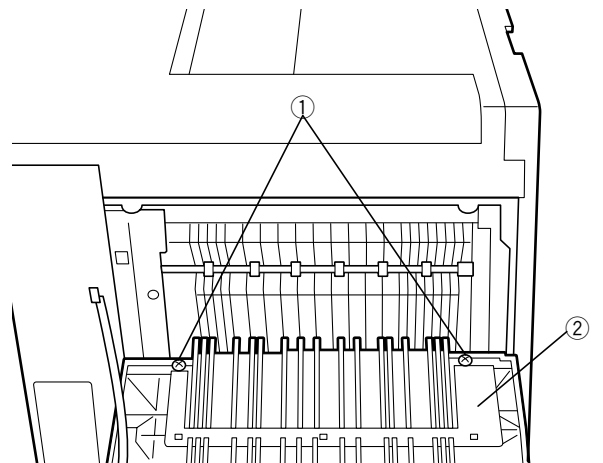

- ① Screws ② Left cover

Figure 3-517

7. Delivery Cover

- 1) Open the delivery cover.
- 2) Extend the two rods attached to the printer, and detach the delivery cover from the rod plates.

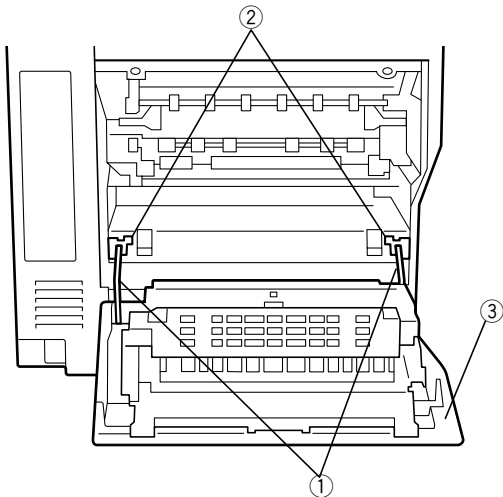

- ① Rods
- ② Rod plates
- ③ Delivery cover

Figure 3-518

- 3) Lift the delivery cover slightly to detach its right; then, detach its left.

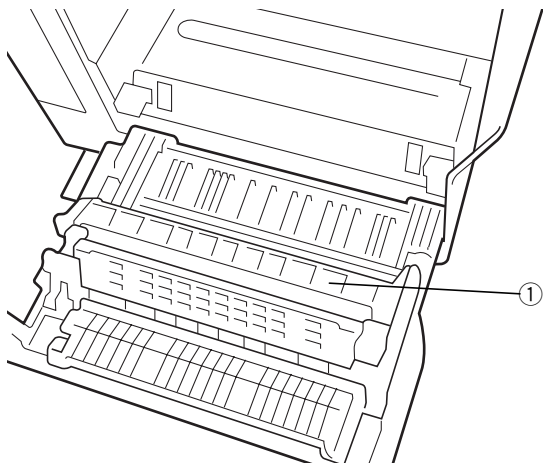

- ① Delivery cover

Figure 3-519

8. Right Cover

- 1) Open the multiffeeder tray.
- 2) Open the right cover.
- 3) Remove the screw, and turn over the pre-exposure LED assembly.

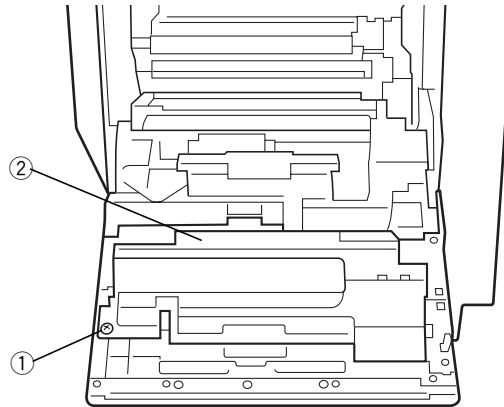

- ① Screw
- ② Pre-exposure LED assembly

Figure 3-520

- 4) Disconnect the two connectors, and detach the pre-exposure LED assembly.

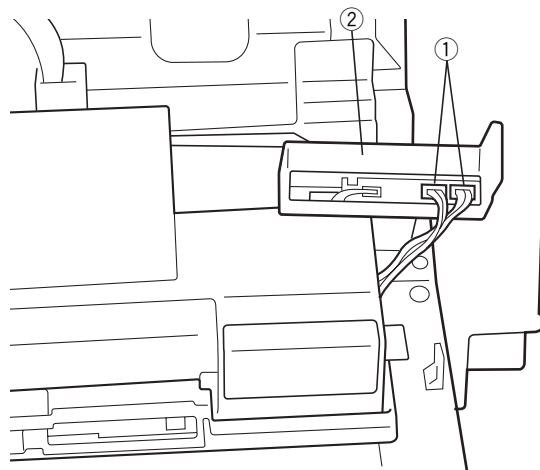

- ① Connector
- ② Pre-exposure LED assembly

Figure 3-521

Caution:

When removing the pre-exposure LED assembly, take care not to apply excess force to the pre-exposure LEDs.

- 5) Remove the two screws, and detach the heat discharge fan 3 together with the fan duct.

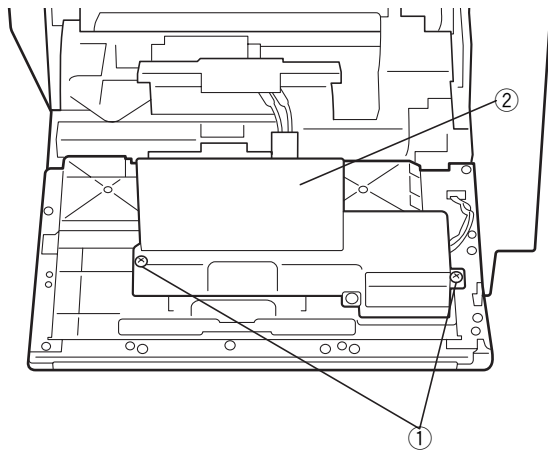

- ① Screws ② Fan duct

Figure 3-522

- 6) Remove the seven screws, and detach the right cover.

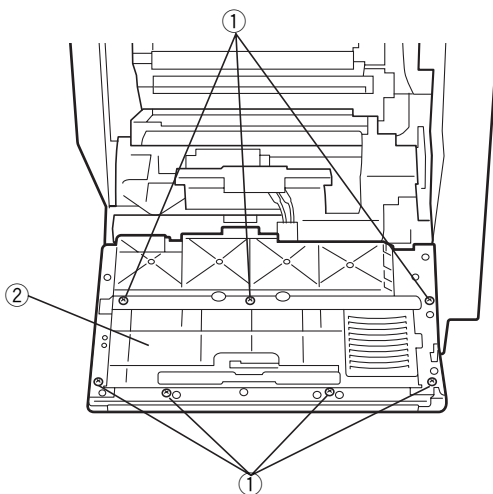

- ① Screws ② Right cover

Figure 3-523

9. Multifeeder Tray

- 1) Open the multifeeder tray.
- 2) Slide the sub tray of the multifeeder tray, and disengage the two claws used to secure the tray in place.

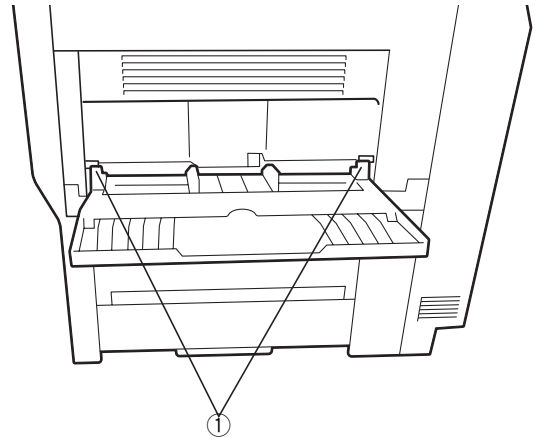

- ① Claws

Figure 3-524

- 3) Disconnect the connector, and remove the multifeeder tray.

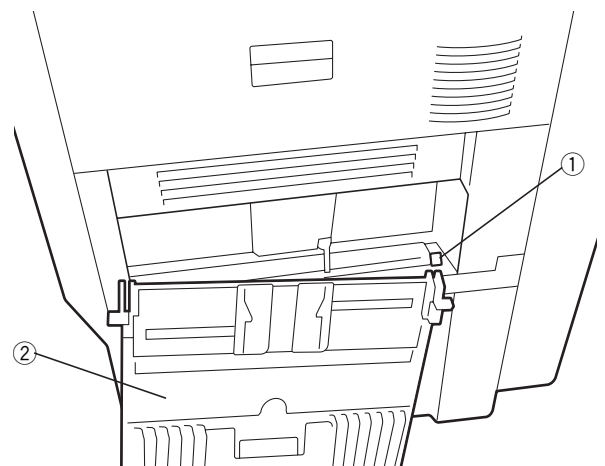

- ① Connector
② Multifeeder tray

Figure 3-525

10. Inside Cover 1

- 1) Remove the front cover by following the steps on p. 3-14.
- 2) Remove the upper cover by following the steps on p. 3-14.
- 3) Open the delivery cover.
- 4) Disengage the two claws, and detach the toner catch tray cover.

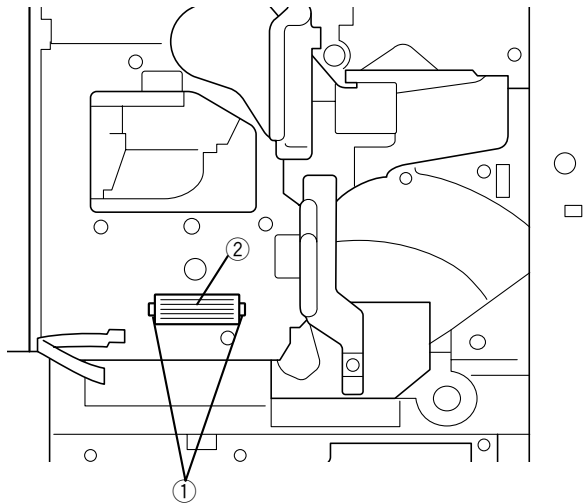

- ① Claws
- ② Toner catch tray cover

Figure 3-526

11. Inside Cover 2

- 1) Open the right cover.
- 2) Remove the front cover according to the steps on p. 3-14.
- 3) Remove the upper cover by following the steps on p. 3-14.
- 4) Remove the screw, and detach the releasing lever 1.

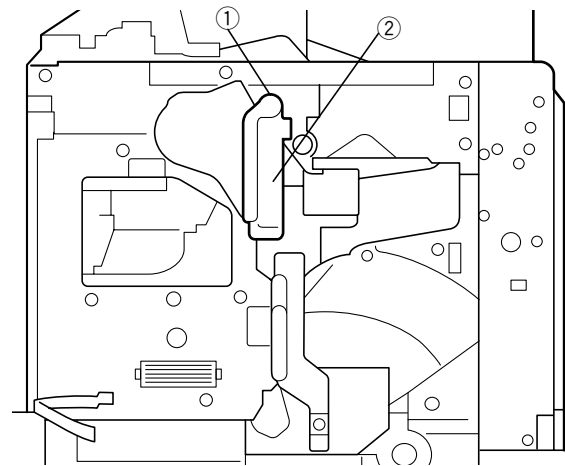

- ① Screw
- ② Releasing lever

Figure 3-528

- 5) Pull out the toner catch tray, and remove the eight screws; then, detach the inside cover 1.

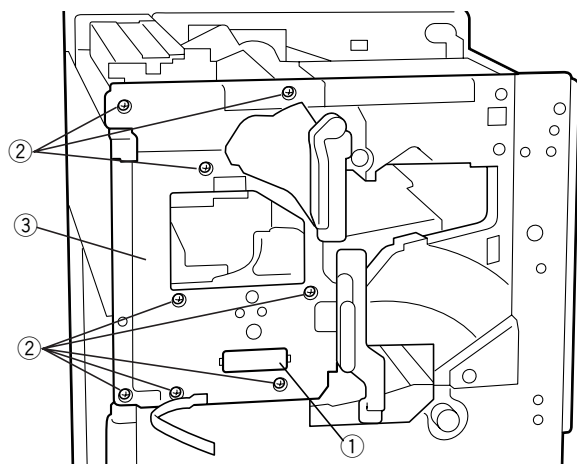

- ① Toner catch tray
- ② Screw
- ③ Inside cover 1

Figure 3-527

- 5) Remove the three screws, and detach

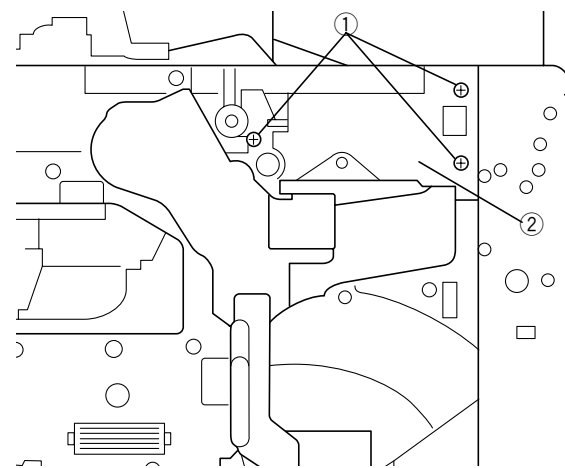

- the inside cover 2.
- ① Screws
- ② Inside cover 2

Figure 3-529

12. Inside Cover 3

- 1) Open the right cover.
- 2) Remove the front right cover by following the steps on p. 3-14.
- 3) Push the releasing lever button; then, remove the two screws, and detach the releasing lever 2.

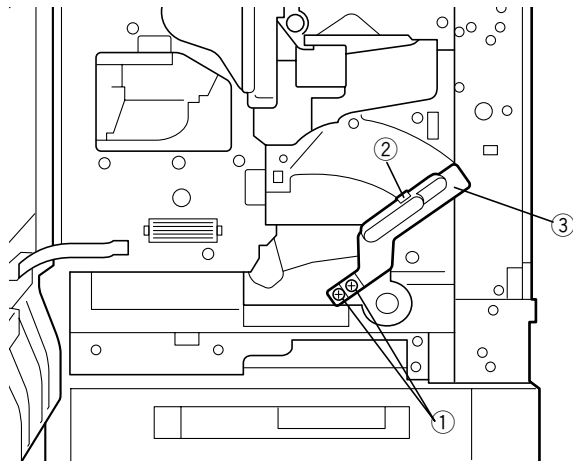

- ① Screws
- ② Releasing lever button
- ③ Releasing lever 2

Figure 3-530

13. Inside Cover 4

- 1) Remove the inside cover by following the steps on p. 3-20.
- 2) Remove the inside cover 3 by performing steps 3) and 4) on p. 320.
- 3) Remove the screw, and detach the jam removing knob.

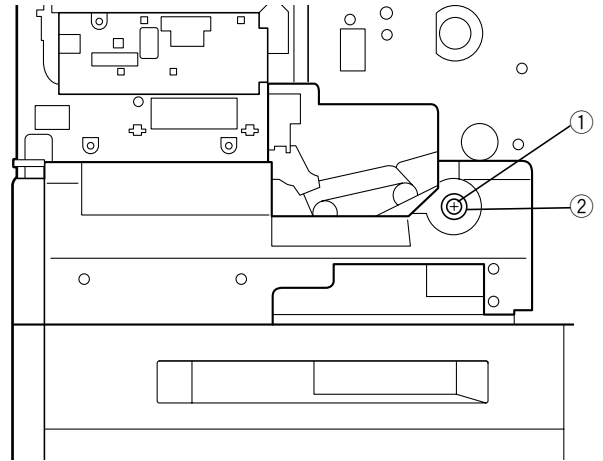

- ① Screw
- ② Jam removing screw

Figure 3-532

- 4) Remove the five screws, and detach the inside cover 3.

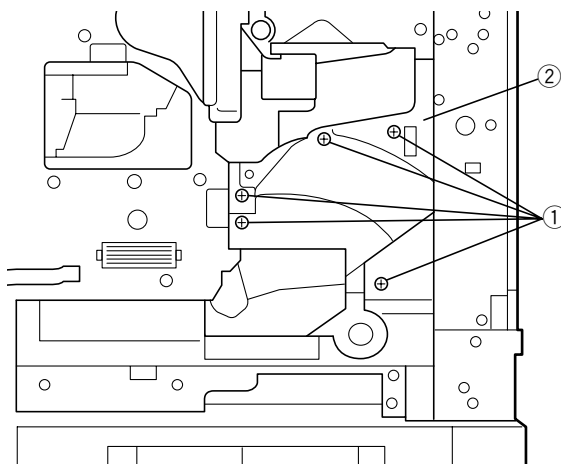

- ① Screws
- ② Inside cover 3

Figure 3-531

- 4) Remove the four screws, and detach the inside cover 4.

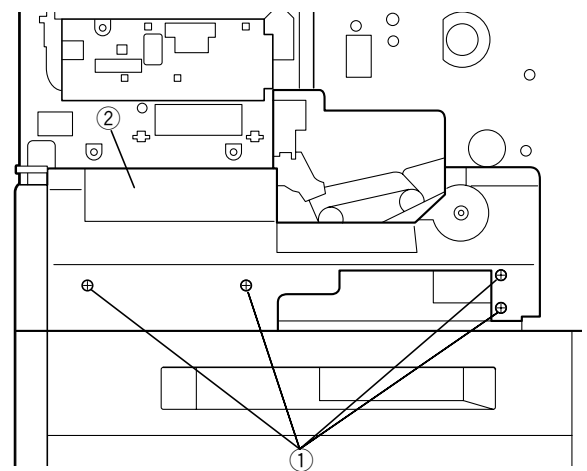

- ① Screws
- ② Inside cover 4

Figure 3-533

B. Door Switch Actuator

1. Construction

The door switch actuator is designed to enable checks on operation while the front cover and the right cover are open, as when checking the image formation on the intermediate transfer drum and paper feeding.

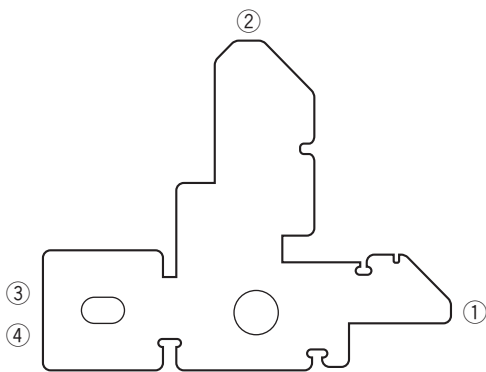

- ① For front cover
- ② For cover laser shutter
- ③ For right cover
- ④ For laser shutter

Figure 3-534

2. Removing the Door Switch Actuator

- 1) Remove the front right cover by following the steps on p. 3-14.
- 2) Remove the screw from behind the front right cover, and detach the door switch actuator (4 pc.).

3. Using the Door Switch Actuator

- a. Front Cover
 - 1) Open the front cover.
 - 2) Insert the door switch actuator as shown.

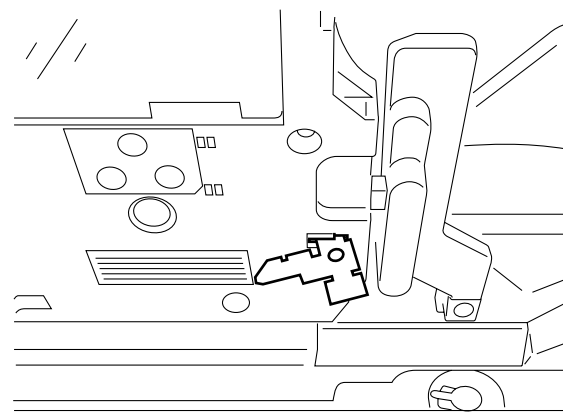
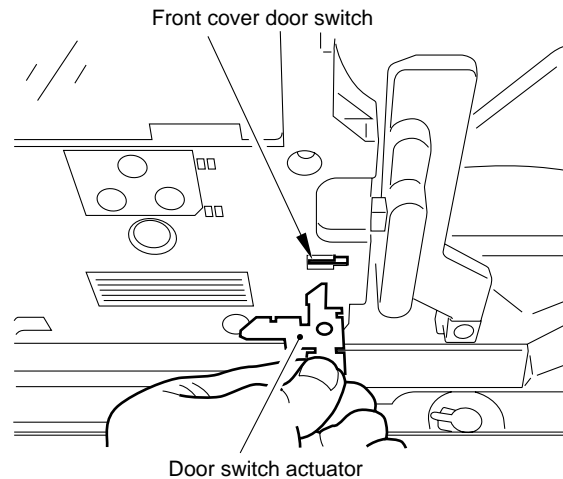

Figure 3-535

b. Front Cover Laser Shutter

- 1) Open the front cover.
- 2) Insert the door switch actuator as shown.

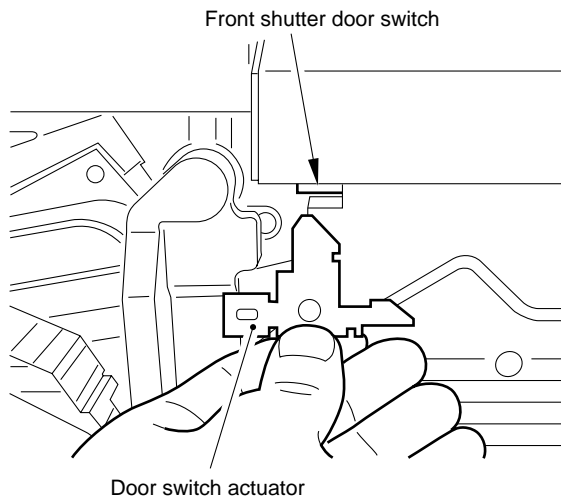

Figure 3-536

c. Right Cover

- 1) Open the front cover.
- 2) Insert the door switch actuator as shown.

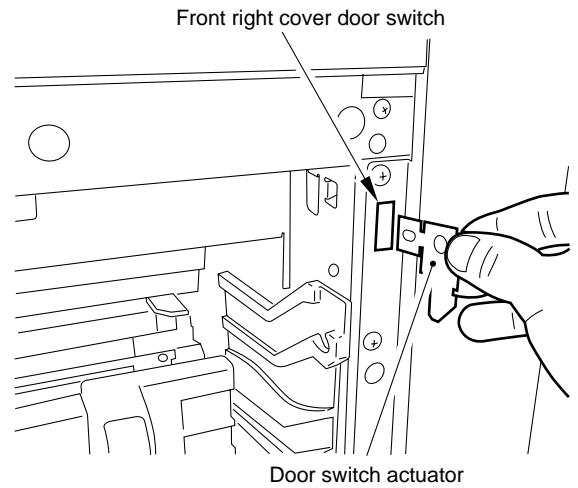
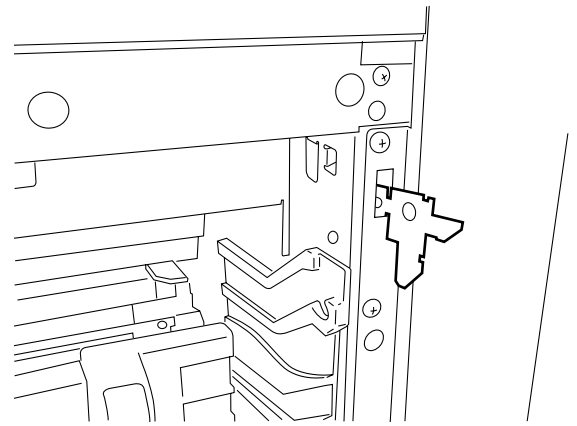
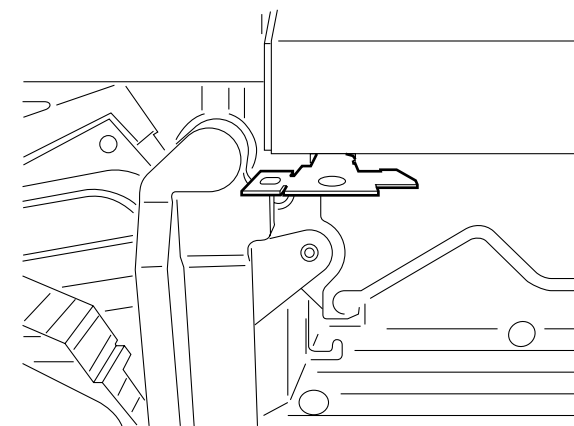
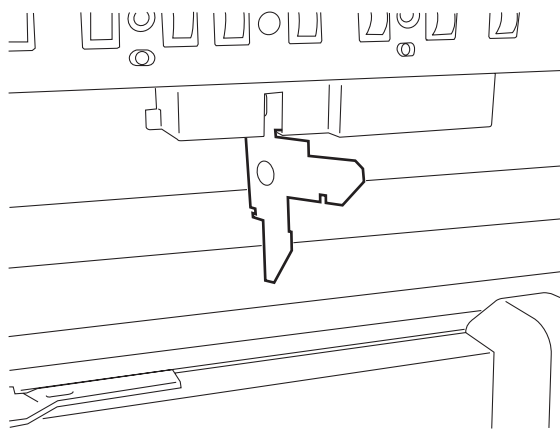
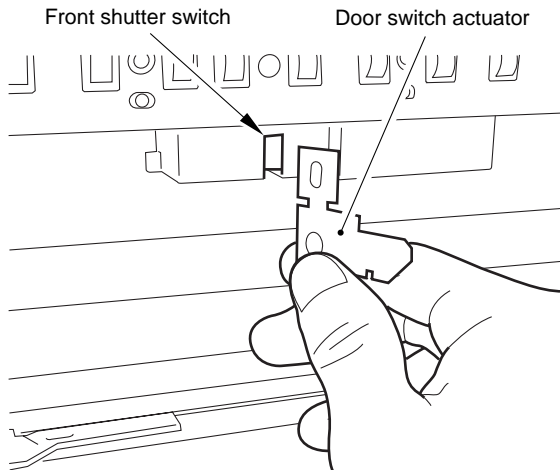

Figure 3-537



- d. Right Cover Laser Shutter
- 1) Open the front cover.
 - 2) Inert the door switch actuator as shown.

Figure 3-538



Caution:

When checking the operation with the right cover open, be sure to place print paper over the density sensor as shown.

This diagram shows the interior of the printer with the right cover open. A sheet of print paper is placed over the density sensor. Labels 'Density sensor' and 'Print paper' point to their respective parts.

C. Laser/Scanner Assembly

1. Construction

The laser/scanner assembly is used to move a laser beam over the photosensitive drum, and is constructed as shown in Figure 3-539.

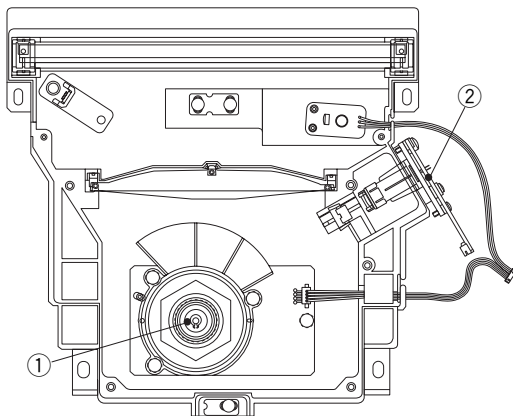

- ① Scanner assembly
- ② Laser assembly

Figure 3-539

2. Removing from the Printer Unit

- 1) Remove the upper over by following the steps on p. 3-14.
 - 2) Remove the four screws, and disconnect the two connectors; then, detach the laser/scanner assembly assembly.
- ① Screws

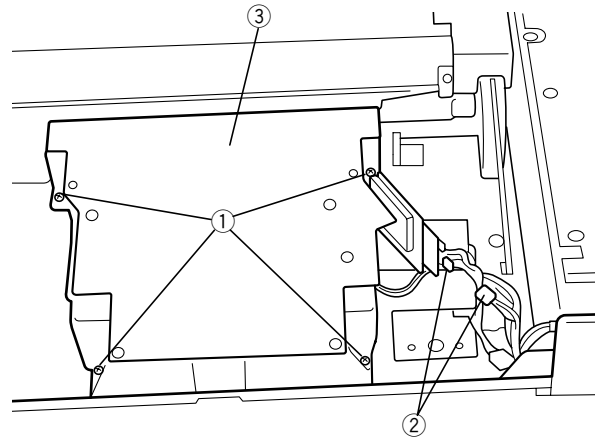

- ② Connectors
- ③ Laser/scanner assembly assembly

Figure 3-540

Caution:

Do not disassemble the laser or scanner assemblies. They cannot be adjusted in the field.

CHAPTER 4

IMAGE FORMATION SYSTEM

This chapter provides descriptions on the machine's image processing operations, functions of each operation, relationships between electrical and mechanical systems, and timing at which each associated part is turned on.

I.	OUTLINE.....	4-1	V.	IMAGE STABILIZATION CORRECTION CONTROL.....	4-21
	A. Construction.....	4-1		A. Environmental Changes Correction Control	4-21
	B. Operations.....	4-2		B. Image Density Correction Control (maximum density control).....	4-21
II.	FORMING LATENT STATIC IMAGES.....	4-5		C. Image Gradation Correction Control (requires a PS/PCL Board)	4-22
	A. Outline.....	4-5		D. Detecting the Density.....	4-23
	B. Drum Cartridge Memory	4-6	VI.	HIGH-VOLTAGE POWER SUPPLY CIRCUIT.....	4-24
	C. Checking the Life of the Photosensitive Drum	4-8		A. Outline.....	4-24
	D. Monitoring the Waste Toner Case.....	4-9		B. High-Voltage PCB 1	4-26
III.	DEVELOPMENT	4-10		C. High-Voltage PCB 2	4-30
	A. Outline.....	4-10		D. Separation Static Eliminating Bias PCB.....	4-33
	B. Controlling the Developing Rotary	4-12	VII.	OTHER CONTROL MECHANISMS.....	4-34
	C. Locking the Developing Rotary	4-14		A. Developing Rotary Motor Control	4-34
	D. Detecting the Absence of the Toner Cartridges	4-14		B. Controlling the Cartridge Motor	4-36
	E. Detecting the Level of Color Toner.....	4-16		C. Controlling the Drum Motor.....	4-37
	F. Checking the Presence/Absence of a Color Toner Cartridge.....	4-17	VIII.	DISASSEMBLY/ASSEMBLY	4-38
	G. Checking the Level of Black Toner and the Presence/Absence of the Black Toner Cartridge	4-17		A. Drive System.....	4-39
IV.	TRANSFER.....	4-18		B. Charging, Developing, and Cleaning.....	4-45
	A. Outline.....	4-18		C. PCBs.....	4-53
	B. Locking the Secondary Transfer Belt.....	4-19			
	C. Controlling the ITD Cleaning Roller.....	4-20			

I. OUTLINE

A. Construction

The image formation system is the core of the machine, and consists of the latent static image formation block (drum cartridge, pre-exposure LED assembly); developing block (color toner cartridges, black toner cartridge, developing rotary assembly); and transfer block (intermediate transfer drum, secondary pre-transfer charging assembly, secondary transfer belt, separation static eliminator, ITD cleaning roller).

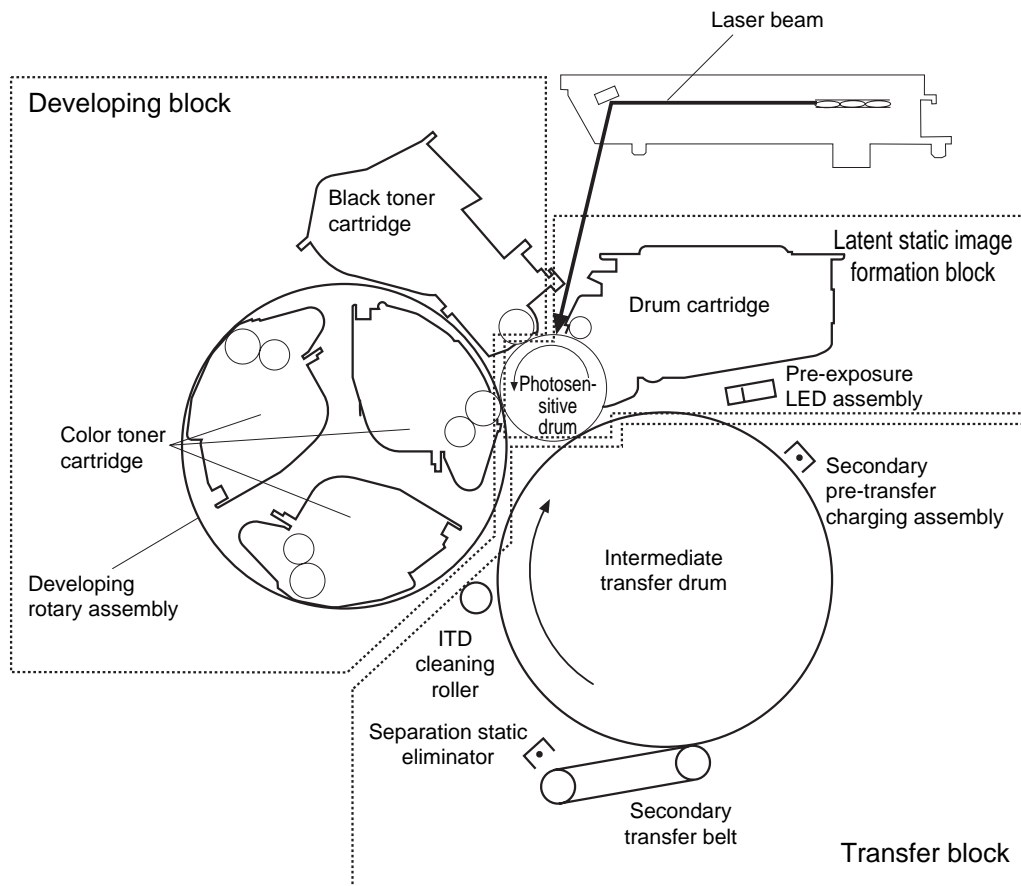

Figure 4-101

B. Operations

In response to the print signal (PRNT*) from the printer board*1, the DC controller PCB drives the photosensitive drum, primary charging roller, developing rotary assembly, intermediate transfer drum, secondary transfer belt, and ITD cleaning roller.

At the same time, it turns on the LEDs of the pre-exposure LED assembly to remove the residual charges from the surface of the photosensitive drum. The primary charging roller then charges the surface of the photosensitive drum to a uniform negative potential; the laser diode directs a laser beam modulated by video data signals to the surface of the photosensitive drum to form a latent static image.

The latent static image formed on the surface of the photosensitive drum is turned into a visible image by toner from the toner cartridge, and is transferred (primary transfer) to the intermediate transfer drum.

1. Full-Color Prints

First, Y (yellow) video data is used to form a latent static image on the photosensitive drum, and the color developing cylinder is positioned against the photosensitive drum by rotating the developing rotary to develop the Y toner. After development, the toner is transferred to the intermediate transfer drum by the positive bias applied to the intermediate transfer drum to end the primary transfer process for Y toner.

The developing rotary is then rotated once again to position the M (magenta) developing cylinder against the photosensitive drum. A latent static image is then formed on the photosensitive drum using M video data, and is developed and transferred (primary) as in the case of Y toner.

The same sequence of operations is performed for C (cyan) toner to complete the development processes, upon which the developing rotary is rotated. At this time, each color developing cylinder is stopped where it will not face the photosensitive drum in preparation for black development. (See Reference.)

Since the black developing cylinder is positioned always to face the photosensitive drum, mere application of a bias starts development unlike color toners. When each color has been developed and primary transfer has been performed four times in sequence, as many as four color toners exist on the intermediate transfer drum to complete a series of primary transfer processes for full-color printing.

2. Mono-Color Printing

In the case of mono-color toner, the toner is deposited on the intermediate transfer drum when the foregoing processes have been performed once, thereby completing the primary transfer processes.

To increase the efficiency of toner from intermediate transfer drum to paper (secondary transfer), the secondary pre-transfer charging assembly makes the charges of toner even. When paper is moved to the intermediate transfer drum, the secondary transfer belt is pushed up so that the paper is brought into contact with the intermediate transfer drum.

The toner on the intermediate transfer drum is transferred to print paper by the work of the positive bias applied to the secondary transfer belt to complete the secondary transfer processes.

The paper is then separated from the secondary transfer belt and sent to the fixing assembly.

*1 Reader controller PCB (when making prints with the reader unit installed).

The residual toner on the photosensitive drum is removed by the cleaning blade, and is collected in the waste toner case inside the drum cartridge. Then, the potential of surface of the photosensitive drum is made even by the pre-exposure assembly and the primary charging roller to prepare for a new latent static image.

The residual toner on the intermediate transfer drum is changed by the ITD cleaning roller, transferred to the photosensitive drum, and collected in the waste toner case inside the drum cartridge.

Caution:

As shown in Figure 4-102, the black developing cylinder is found behind the roller developing cylinders when we think in terms of the direction of rotation of the photosensitive drum. If a color developing cylinder is in contact with the photosensitive drum when black toner is being developed, the black toner image would be disrupted by the color developing cylinder. This is why each color developing cylinder is moved away from the photosensitive drum when developing black toner.

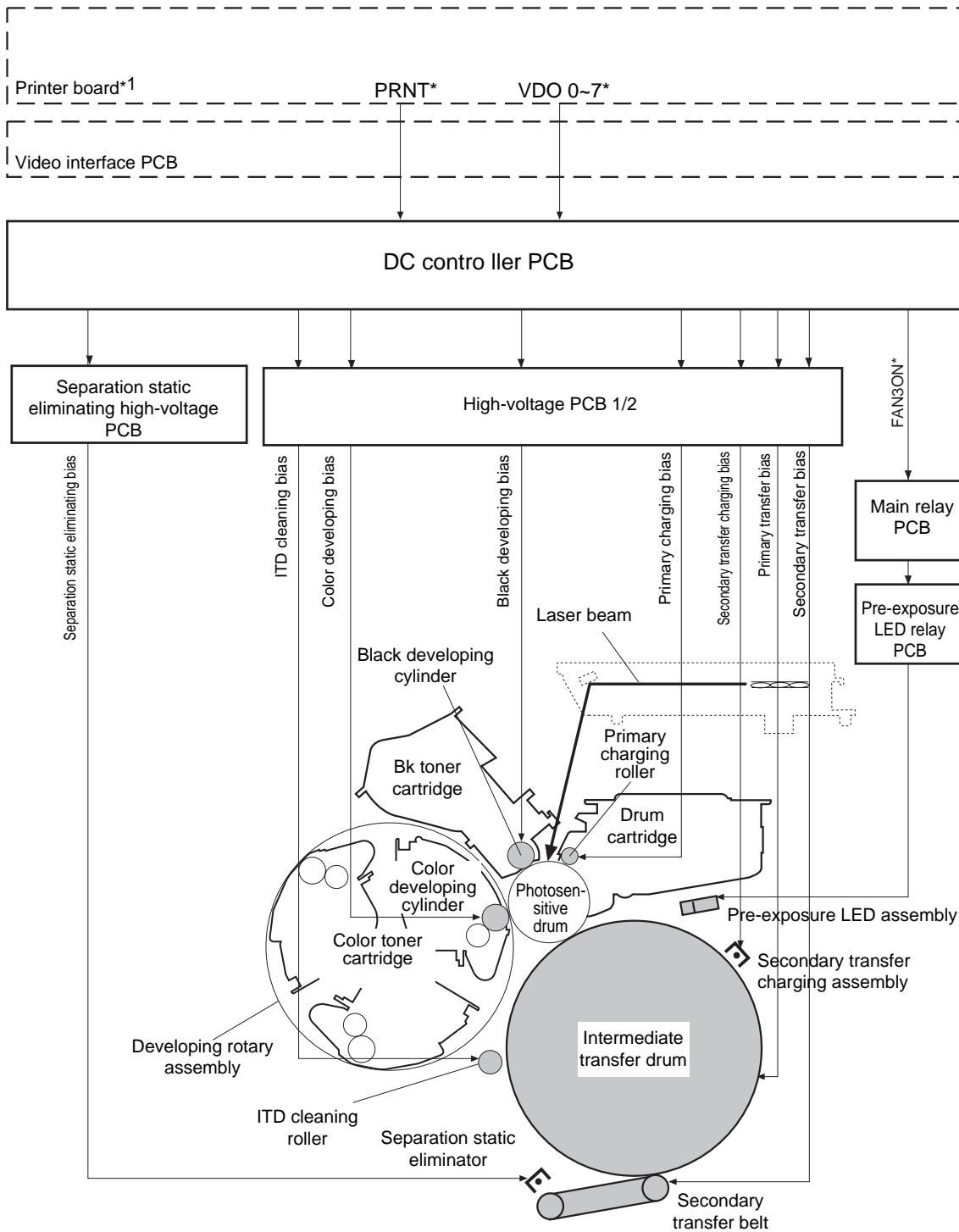

Figure 4-102

*1 Reader controller PCB (when making copies with the reader unit installed).

II. FORMING LATENT STATIC IMAGES

A. Outline

The latent static image formation block consists of the drum cartridge and the pre-exposure LED assembly.

The drum cartridge houses the photosensitive drum, primary charging roller, waste toner case, drum cartridge memory, toner feeding roller, and stirring plate.

The photosensitive drum, toner feeding roller, and stirring plate are rotated by the drum motor (M2), and the primary charging roller rotates in conjunction with the photosensitive drum.

The waste toner inside the drum cartridge is monitored by the waste toner detecting assembly. The life of the photosensitive drum, on the other hand, is monitored by the DC controller PCB, and the findings are stored in the drum cartridge memory inside the drum cartridge.

The pre-exposure LEDs are designed to expose the surface of the photosensitive drum at specific timing.

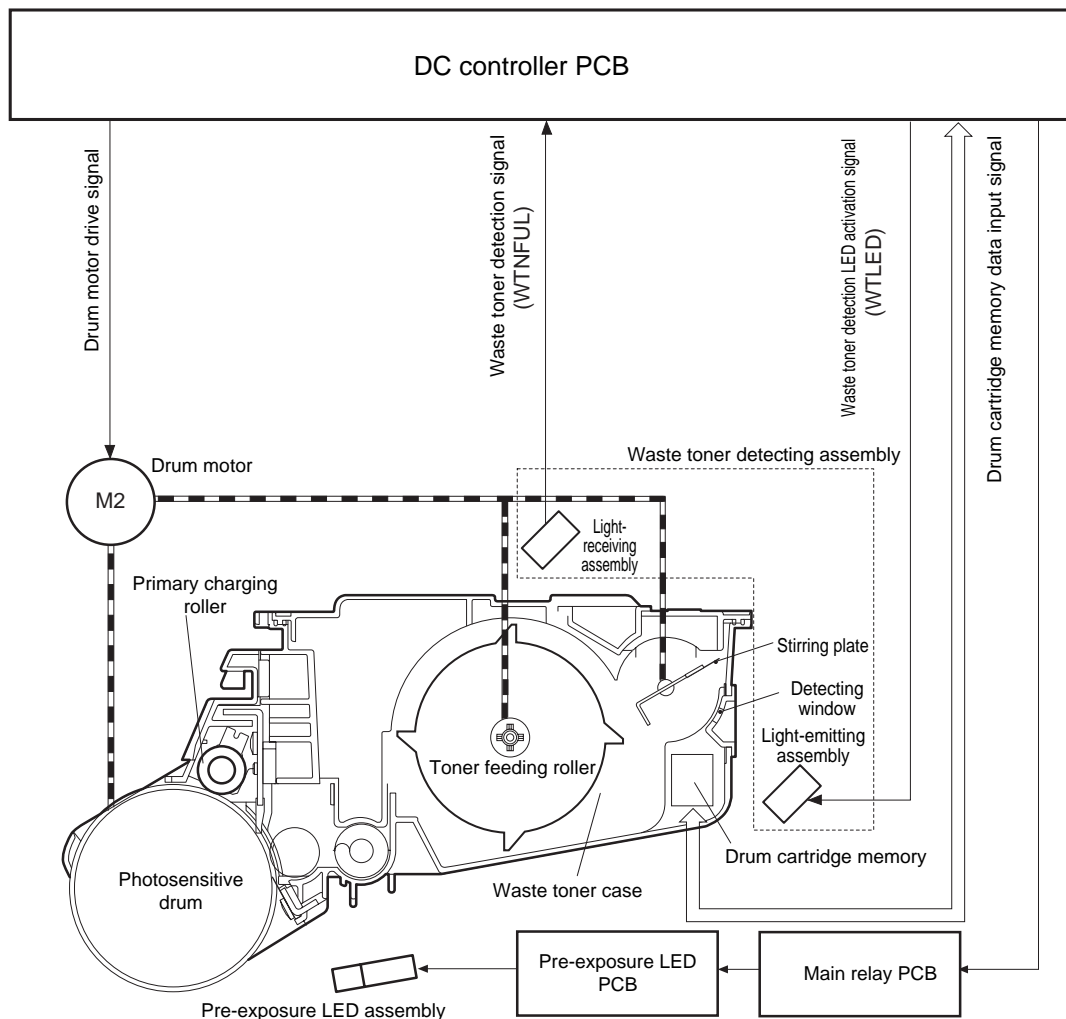

Figure 4-201

B. Drum Cartridge Memory

The drum cartridge memory (EEPROM) contains two areas: ROM area and RAM area. The ROM area retains an ID code specific to the drum cartridge, and is used exclusively for reading. The DC controller PCB reads the ROM area of the drum cartridge when the power switch is turned on or the cover is closed to check if the correct cartridge is set.

The RAM area allows both reading and writing, and the DC controller PCB reads from the drum cartridge memory at specific timing to check the presence/absence or the life of the drum cartridge.

The timing at which the DC controller PCB reads and writes data stored in the RAM area of the drum cartridge is as follows:

Reading

- When the power switch is turned on.
- When the cover is closed.

Writing

- When the power is turned off.
- When the cover is opened.
- At the end of printing (in the case of continuous printing, at the end of continuous printing, or at the end of jam removal).

The copier remembers a fault, if any, in the drum cartridge at time of reading/writing. If writing fails (or reading fails three times consecutively), i.e., an error check sum, the DC controller PCB communicates the fact to the printer board*1 as a drum cartridge memory fault.

*1 Reader controller PCB (when making copies with the reader unit installed).

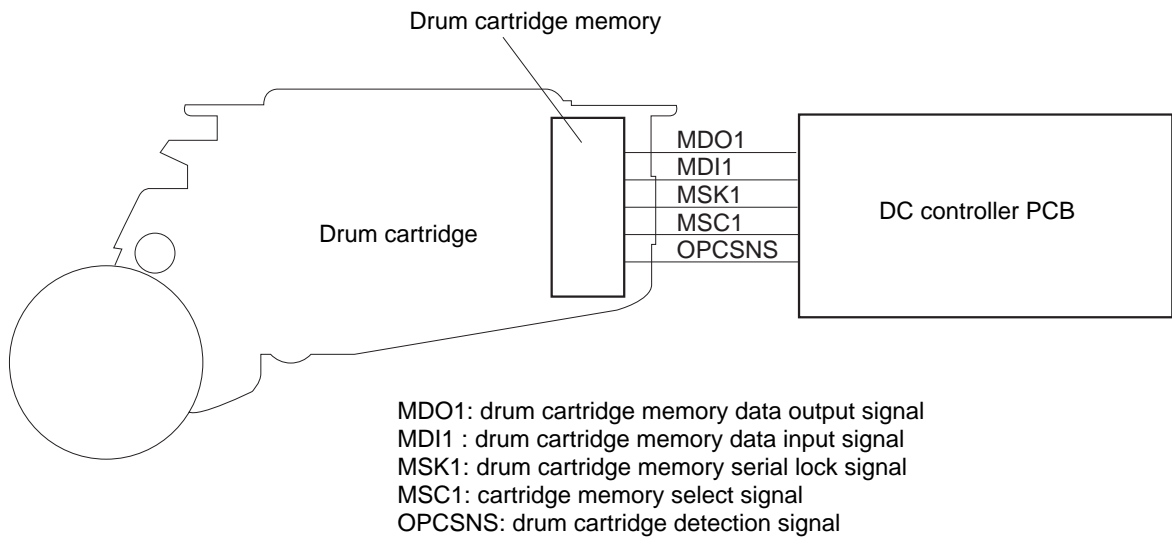

Figure 4-202

Reference:

E810: absence of the drum cartridge.

Caution:

If you have replaced the drum cartridge, be sure to execute auto gradation correction control in user mode.

C. Checking the Life of the Photosensitive Drum

The DC controller PCB makes a check to find out from the data in the drum cartridge memory whether the photosensitive drum has exceeded its life.

The life data is stored in the drum cartridge memory, and the DC controller updates the data at such times as programmed. When the data indicates a specific value, the DC controller PCB judges the fact as the end of the life of the photosensitive drum, and warns the reader controller PCB of the fact and, at the same time, writes the data to the drum cartridge memory.

The machine remains capable of making prints even after the warning has been issued. The DC controller PCB, however, starts to count imaging pages, and will identify the end of the life of the photosensitive drum when the count reaches a specific value, upon which it will stop the copier and communicate the fact to the printer board*1.

*1 Reader controller PCB (when making prints with the reader unit installed).

Reference:

Service mode DISPLAY

0: normal

1: end of life warning 1

2: end of life warning 2

4: drum cartridge memory error

E814: stops the machine at the end of life.

If the reader unit is installed, checks may be made by selecting COPIER>DISPLAY>SENSOR>DRUMLIFE in service mode.

Reference:

The term "imaging pages" means the number of images (Y, M, C, or Bk) written on the photosensitive drum. For example, in the case of a 4-full-color print, the count is incremented by '4'; in the case of a mono-color print (Y, M, C, or Bk), it is incremented by '1'.

D. Monitoring the Waste Toner Case

The toner inside the waste toner case is monitored by the waste toner detecting assembly mounted to the drum cartridge.

The detecting assembly consists of a light-emitting section and a light-receiving section. The light generated by the light-emitting section is directed to the detecting window of the drum cartridge. It moves through the cartridge when the stirring plate inside moves toner away from around the detecting window. The light is then detected by the light-receiving section through the waste toner case; the DC controller PCB finds out the time to when waste toner once again covers the detecting window.

When the period during which light is passing through is shorter than a specific value, the DC controller PCB will identify the fact as a waste toner full warning condition, and communicates it to the printer board^{*1}. It also writes the data to the drum cartridge memory.

The copier remains capable of making copies after the warning, but the DC controller PCB starts counting the prints made since the warning has been issued; it will identify a waste toner full condition when the count reaches a specific value, and will stop the machine and communicate the fact to the printer board^{*1}.

^{*1} Reader controller PCB (when making prints with the reader unit installed).

Reference:

COPIER>DISPLAY>SENSOR>W-TONER (indicated on the control panel if the reader unit is installed)

0: not full.

1: full warning.

Reference:

E013: stops the machine in response to waste toner case full condition.

E019: waste toner detecting assembly malfunction.

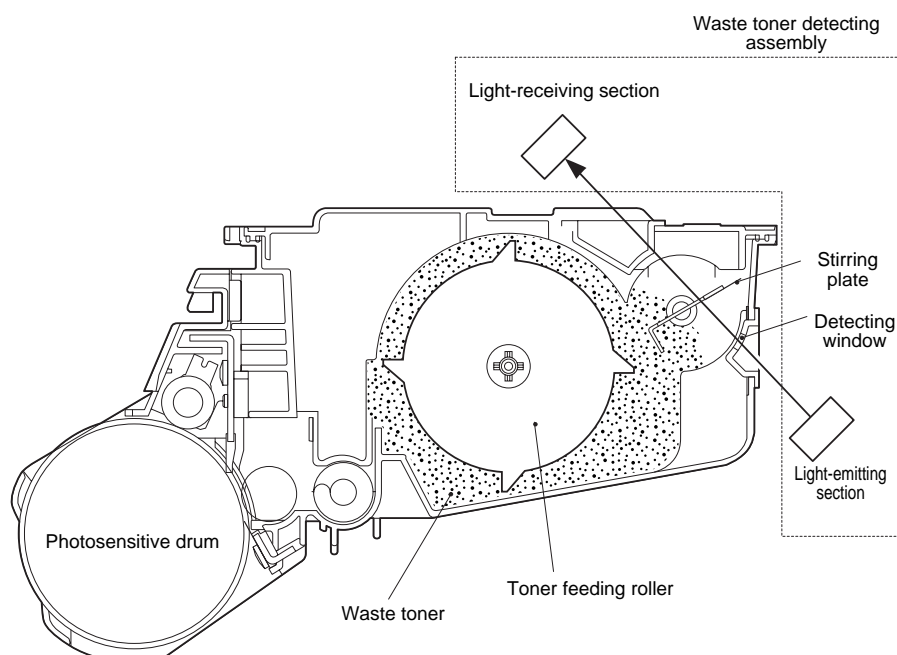

Figure 4-203

III. DEVELOPMENT

A. Outline

The developing assembly consists of three color toner cartridges and the developing rotary assembly to which they are mounted and the black toner cartridge.

The developing rotary assembly rotates clockwise by the work of the developing rotary motor (M1); inside, the yellow, magenta, and cyan color toner cartridges are arranged in the order indicated and are positioned against the photosensitive drum as needed.

The black toner cartridge is positioned so that it always faces the photosensitive drum; during development of black toner, all color toner cartridges are moved away so that they will not face the photosensitive drum.

The color developing cylinder and the black developing cylinder are rotated by the cartridge motor (M3).

The developing assembly is equipped with four sensors, each serving to detect the position of the developing rotary position (PS3), color toner cartridge level (PS621), presence of a color toner cartridges (PS1901C), or color toner cartridge releasing lever (PS1902).

A single switch is used to check the presence/absence of the black toner cartridge (SW644), and the toner antenna inside the black toner cartridge is used to detect the level of black toner.

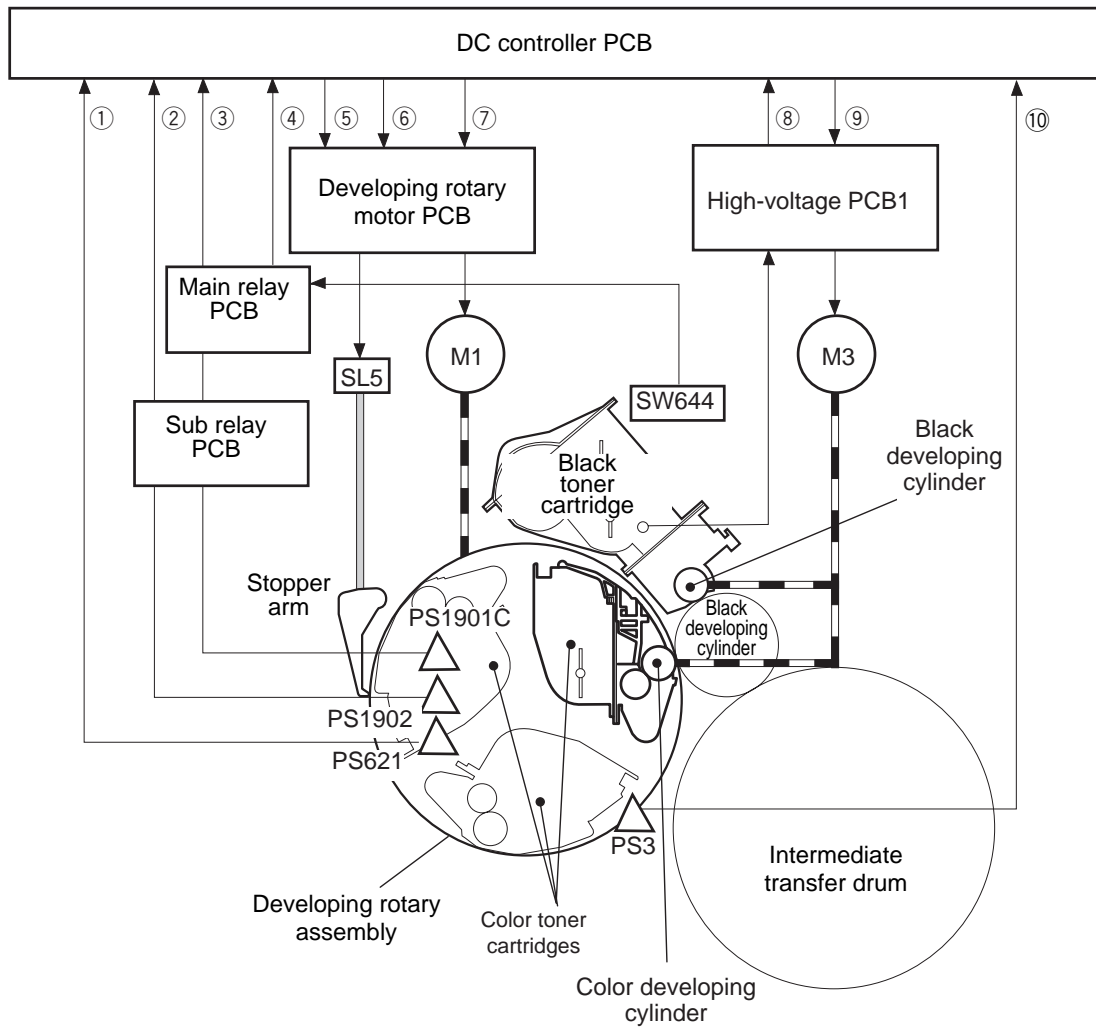

- PS3: developing rotary position sensor
- PS621: color toner cartridge level sensor
- PS1902: color toner cartridge releasing lever sensor
- PS1901C: color toner cartridge sensor
- SL5: developing rotary stopper solenoid
- SW644: black toner cartridge sensor
- M1: developing rotary motor
- M3: cartridge motor

- ①: color toner cartridge level detection signal
- ②: color toner cartridge releasing lever detection signal
- ③: color toner cartridge detection signal
- ④: black toner cartridge detection signal
- ⑤: developing rotary stopper signal
- ⑥: developing rotary stopper releasing signal
- ⑦: developing rotary motor drive signal
- ⑧: black toner cartridge level detection signal
- ⑨: cartridge motor drive signal
- ⑩: developing rotary position detection signal

Figure 4-301

B. Controlling the Developing Rotary

When the DC controller PCB receives the print signal (PRNT*) from the printer board*1, it generates the developing rotary motor drive signal to turn on the developing rotary motor (M1) so that the developing rotary starts normal rotation.

When the DC controller PCB detects that the developing rotary has rotated to a point of deceleration, it slows down the developing rotary motor. Then, when it detects that the developing rotary has rotated to a stop point, it stops the developing rotary motor to stop the developing rotary.

The speed of rotation and the stop position of the developing rotary are controlled by the DC controller PCB in reference to the period over which the 8 flags behind the developing rotary move past the developing rotary position sensor (PS3). As many as eight flags are used: home position flag (serving also as the black toner cartridge stop position flag); color cartridge stop position flag for each color (3 pc.); and deceleration flags (4 pc.).

The stop position flag (3 pc.) for each color cartridge also serves as the cartridge removal deceleration flag.

When PS3 detects a flag, the developing rotary position detection signal (DEVHP*) goes '1'. The DC controller PCB finds out the home position flag with reference to the time at which DEVHP* goes '1', and the position of the stop position flag and the deceleration flag with reference to its time counter reading.

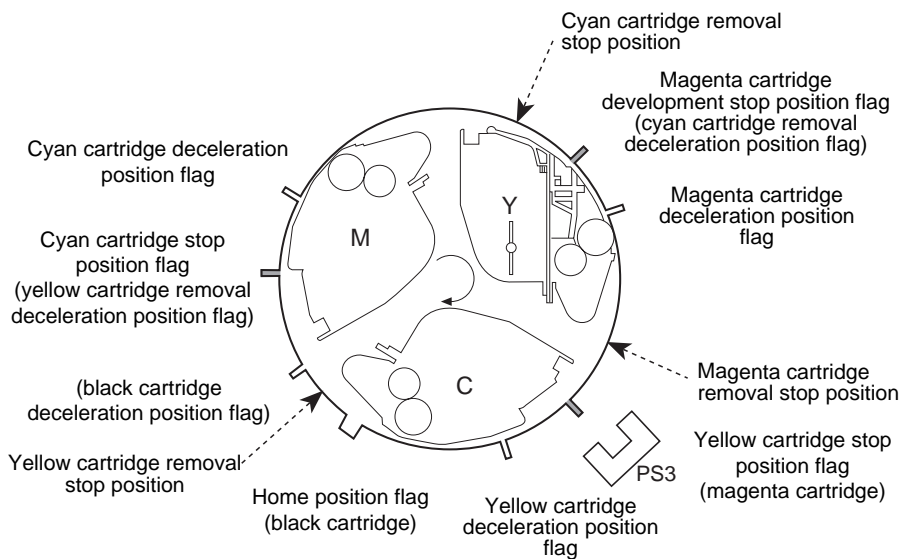

Yellow Cartridge Stop Position (facing against the photo sensitive drum)

Figure 4-302

If PS3 detects any of the following as a fault in the developing rotary assembly, the DC controller PCB recognizes the fault and communicates the fact to the printer board*1 to stop the machine.

- 1) PS3 does not detect the home position flag.
- 2) PS3 detects an error between rotation position flags.
- 3) PS3 cannot detect a flag width different from the stop position flag.

*1 Reader controller PCB (when making prints with the reader unit installed).

Reference: _____

E021: fault in the developing rotary assembly.

C. Locking the Developing Rotary

When the cartridge moves to its point of removal, the stopper lever is pushed to the developing rotary assembly to lock the developing rotary assembly in position.

When the turret button (Figure 1-402) is pushed when replacing a color toner cartridge, the developing rotary assembly rotates; then, as soon as the color toner cartridge stops at its position of removal, the DC controller PCB causes the developing rotary stopper signal (STPROT) to go '1' and the developing rotary stopper release signal (RLSROT) to go '0' so that the developing rotary stopper solenoid (SL5) pushes against the stopper lever to lock the developing rotary in place.

When the cartridge has been replaced and the toner cartridge cover has been closed, the DC controller PCB causes the developing rotary stopper signal (STPROT) to go '0' and the developing rotary stopper release signal (RLSROT) to go '1' so that the stopper lever is pulled back to release the developing rotary.

D. Detecting the Absence of the Toner Cartridges

To prevent the absence of a color toner cartridge, the machine is equipped with a cartridge releasing lever sensor.

This sensor is a reflection type sensor consisting of a light-emitting section and a light-receiving section. If the cartridge releasing lever is not set correctly, the light from the light-emitting section will be reflected by the cartridge releasing lever and detected by the light-receiving assembly.

The DC controller PCB monitors the cartridge releasing lever sensor with reference to the timing at which the cartridge cover is closed; when the cartridge releasing lever detection signal (RLOCKS) goes '0', it communicates the fact to the printer board*1 as the absence of a color cartridge, thereby stopping the machine and indicating a message to this effect.

*1 Reader controller PCB (when making prints with the reader unit installed).

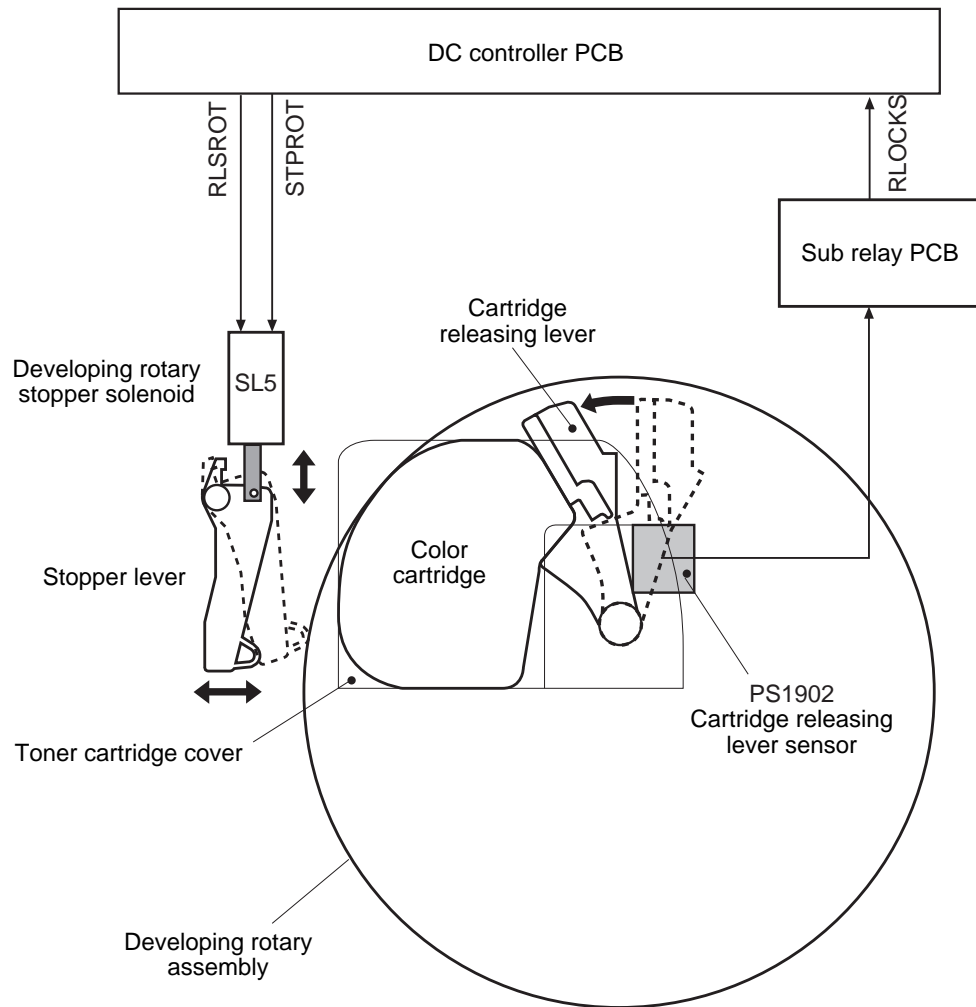

Figure 4-303

E. Detecting the Level of Color Toner

The level of color toner is detected by the color toner level sensor (PS621), which consists of a light-emitting section and a light-receiving section.

The light from the light-emitting section found on the outside of the toner cartridges moves through the light guide to reach the detecting window inside the cartridge.

The stirring plate inside the cartridge moves away toner from around the detecting window so that the light moves through the cartridge and reaches the light-reflecting section of the sensor through the light guide. Then, as toner once again starts to cover the detecting window, the DC controller PCB finds out the time that passes before the light is blocked.

When the period during which light moves through the cartridge is longer than a specific value, the DC controller PCB identifies the condition as absence of color toner, and communicates the fact to the printer board*1.

The machine checks the level of toner in reference to the timing at which the stirring plate is rotating when power is turned on or when making prints.

*1 Reader controller PCB (when making prints with the reader unit installed).

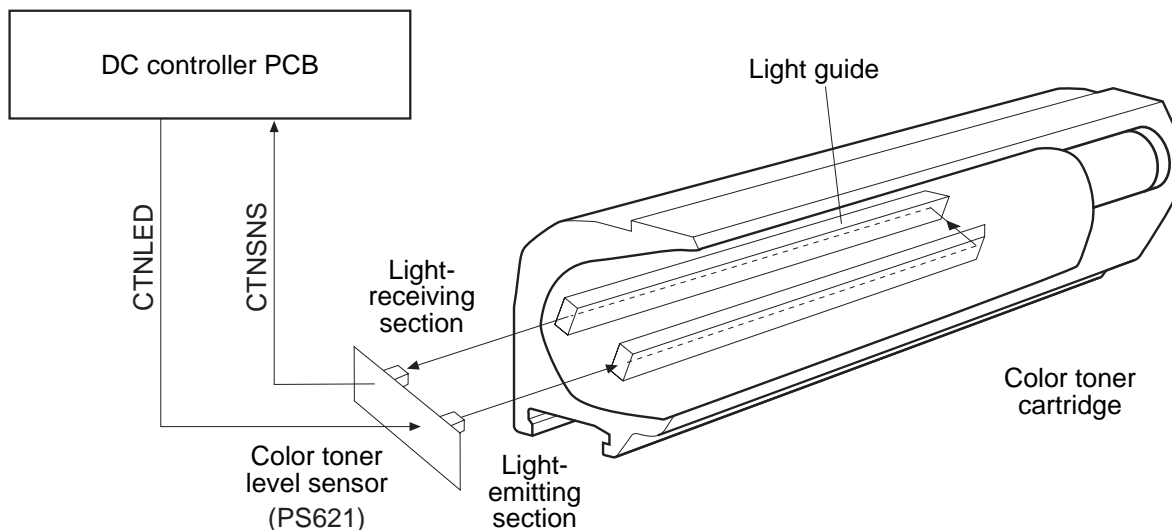

Figure 4-304

F. Checking the Presence/Absence of a Color Toner Cartridge

The presence/absence of a color toner cartridge is detected by the cartridge sensor (PS1901C), which consists of a light-emitting section and a light-receiving section.

When the color toner cartridge in question is set, the light from the light-emitting section is reflected by the cartridge and reaches the light-receiving section; in the absence of the cartridge, on the other hand, it enters the machine, not reaching the light-receiving section. The DC controller PCB identifies the condition as the absence of the color toner cartridge, and communicates the fact to the printer board*1 to stop the machine.

The machine checks the presence of cartridges when the power is turned on or when the various covers have been opened/closed.

*1 Reader controller PCB (when making prints with the reader unit installed).

G. Checking the Level of Black Toner and the Presence/Absence of the Black Toner Cartridge

The level of black toner is checked by the antenna sensor inside the black toner cartridge. The output of the toner antenna (toner level detection signal) is sent to the DC controller PCB through the high-voltage PCB, which checks on the signal at such times as black developing AC bias is applied to the black developing cylinder.

If the level is below a specific value, the DC controller PCB communicates the absence of black toner to the printer board*1.

The presence/absence of the black toner cartridge is checked by a switch (black toner cartridge detecting switch SW644) inside the copier.

*1 Reader controller PCB (when making prints with the reader assembly installed).

IV. TRANSFER

A. Outline

The transfer block consists of the intermediate transfer drum, secondary pre-transfer charging assembly, secondary transfer belt, separation static eliminator, and ITD cleaning roller, and serves to transfer the toner image from the photosensitive drum to paper and to remove residual toner.

The intermediate transfer drum is rotated by the drum motor (M2), and the secondary transfer belt is rotated by the main motor (M4). When the secondary transfer belt clutch (CL4) turns on, the secondary transfer belt is forced against the intermediate transfer drum. When the ITD cleaning roller solenoid (SL1) turns on, on the other hand, the ITD cleaning roller is forced against the intermediate transfer drum.

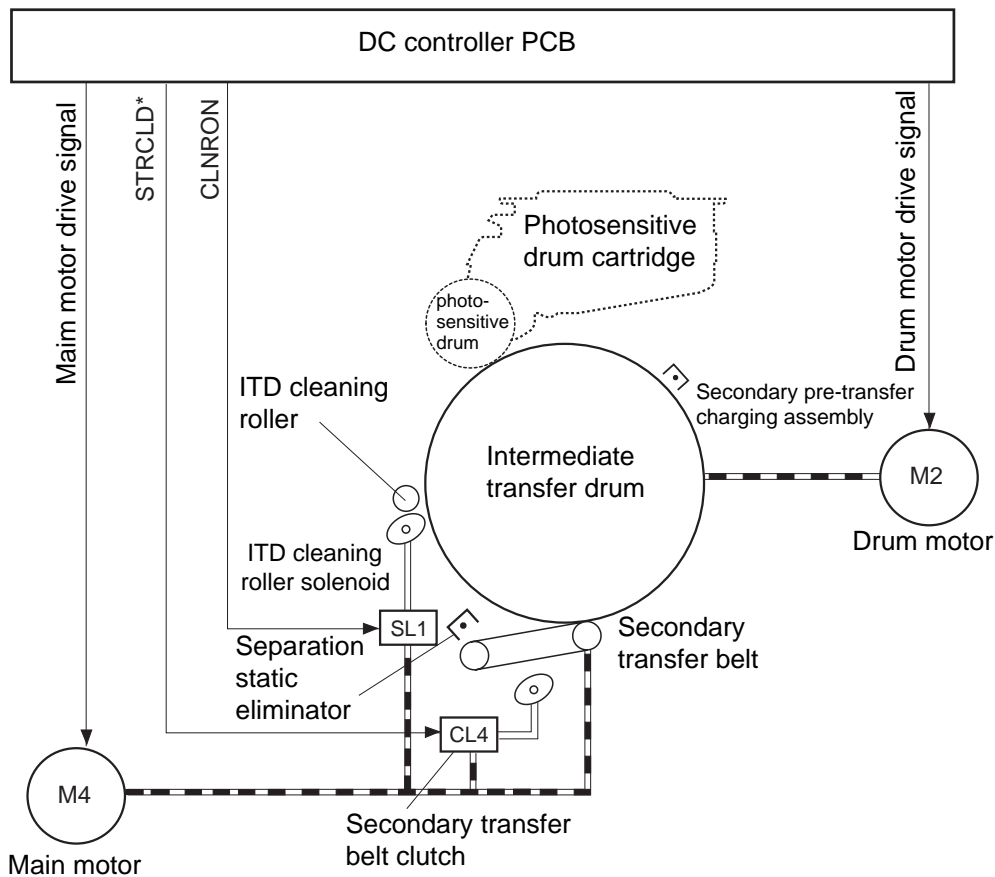

Figure 4-401

B. Locking the Secondary Transfer Belt

The secondary transfer belt assembly is locked to the intermediate transfer drum on which paper is placed before starting secondary transfer.

Normally, the secondary transfer belt assembly is away from the intermediate transfer drum, and is locked to the holding transfer drum as needed.

The DC controller PCB causes the secondary transfer belt clutch drive signal (STGR-CLD8) to go '0' as soon as paper reaches the secondary transfer belt assembly, turning on the secondary transfer belt clutch (CL4), driving the secondary transfer belt cam, and pushing up the secondary transfer belt assembly.

As a result, print paper is forced against the intermediate transfer drum, and the toner is transferred for the intermediate transfer drum to the print paper.

When paper moves away and secondary transfer ends, the DC controller CPB turns off the secondary transfer belt clutch (CL4) to move the secondary transfer belt away from the intermediate transfer drum.

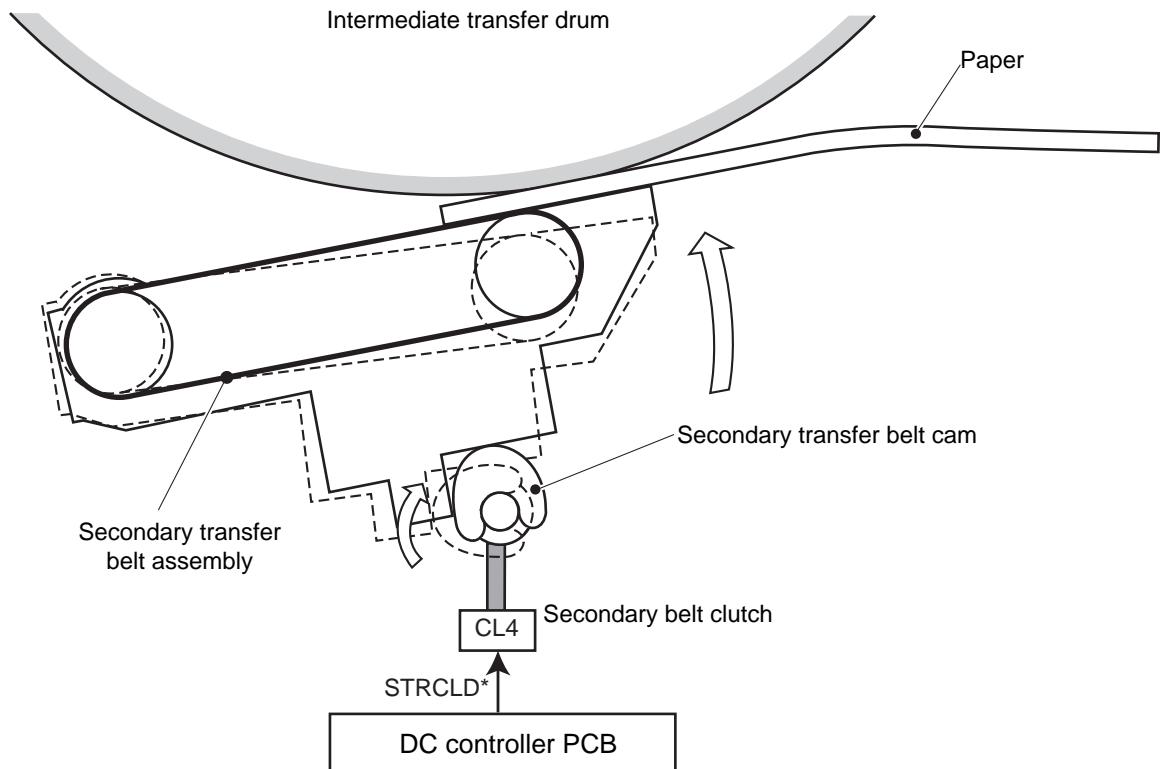

Figure 4-402

C. Controlling the ITD Cleaning Roller

The ITD cleaning roller is pushed against the intermediate transfer drum immediately before secondary transfer.

Normally, the ITD cleaning roller remains away from the intermediate transfer drum, and is forced against the intermediate transfer drum as needed.

The DC controller PCB causes the ITD cleaning roller solenoid drive signal (CLNRON) to go '1' at the appropriate timing; in response, the ITD cleaning roller solenoid (SL1) turns on, the ITD cleaning roller cam starts to operate, and the ITD cleaning roller moves against the intermediate transfer drum.

When secondary transfer ends and ITD cleaning is turned on, the DC controller PCB turns off the ITD cleaning roller solenoid (SL1) to move the ITD cleaning roller from the intermediate transfer drum.

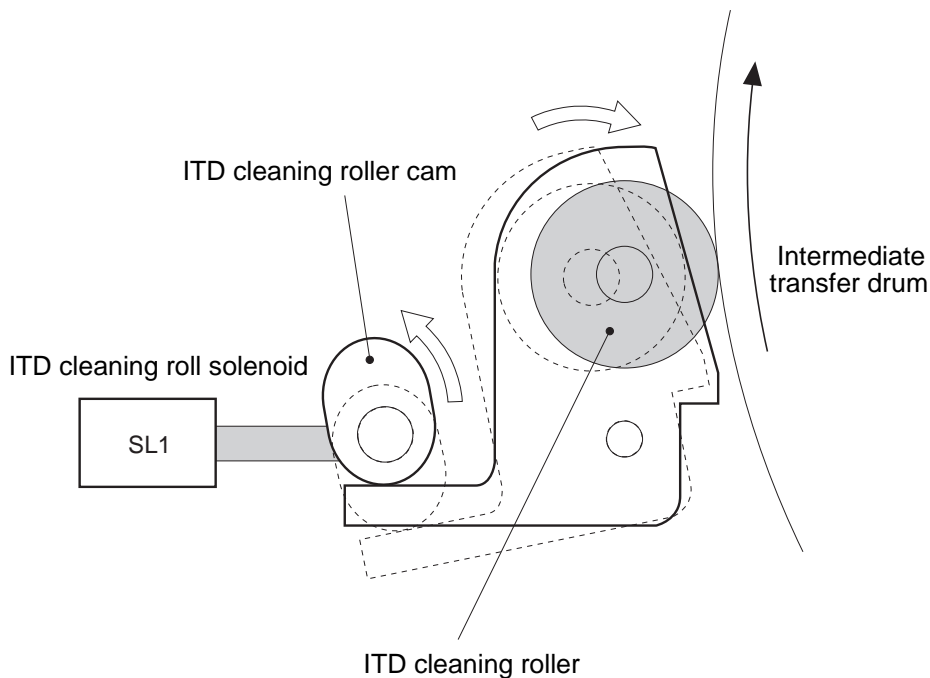

Figure 4-403

V. IMAGE STABILIZATION CORRECTION CONTROL

The machine executes image stabilization correction control to suppress fluctuations in image density caused by changes in the site environment, changes in the photosensitive drum over time, and changes in toner. The control mechanism consists of environmental changes correction control, image density correction control, and image gradation correction control.

A. Environmental Changes Correction Control

The DC controller PCB identifies the condition of the site based on the machine internal temperature and humidity detection signals from the temperature and humidity sensor on the temperature/humidity sensor PCB, and performs the following to ensure optimum images:

- Determines whether to turn on or off the separation static eliminating bias.
- Determines the target density for image density correction control.

The copier executes environmental changes correction control at the following timing:

- Before starting image density correction control.
- Every 30 min after the end of image density correction control.

B. Image Density Correction Control (maximum density control)

The DC controller PCB draws a density detection pattern for each color on the intermediate transfer drum to suit the environmental conditions whose data is obtained as a result of environmental changes correction control.

Then, it checks the density detection pattern using the density sensor to determine the developing bias and the primary charging bias most likely to ensure stable density for the color in question.

Image density correction control is performed for the following:

- At the end of environmental changes correction control at power-on.
- At the end of making a specific number of prints.
- After returning from power save mode.
- When a toner cartridge has been taken out and put back in. (Note 1)
- When the drum cartridge has been replaced. (Note 2)
- When appreciable changes occurred in the environment as part of environmental changes control.

Note:

1. A color toner cartridge is assumed to have been taken out and put back in when the toner cartridge cover is opened. For the control mechanism to start when the color toner cartridge cover is closed, the right cover must be closed and, at the same time, the black toner cartridge and the drum cartridge must be inside (so that the color toner cartridge cover may be checked).

The black toner cartridge is checked by the black toner cartridge detecting switch. For the control mechanism to start, the right cover and the color toner cartridge cover must be closed and, at the same time, the black toner cartridge and the drum cartridge must be set inside.

2. The right cover and the toner cartridge cover must be closed and, at the same time, the black toner cartridge and the drum cartridge must be set inside for the presence of the drum cartridge to be recognized. (Otherwise, density correction control is not performed.)

C. Image Gradation Correction Control (requires a PS/PCL Board)

The DC controller PCB draws a density detection pattern for each color on the intermediate transfer drum using a developing bias and a primary charging bias determined as a result of image density correction control using image data from the printer board (PS/PCL Board).

Then, the DC controller PCB checks the density detection pattern using the density sensor, and sends data to the printer board, which in response performs gradation correction to ensure ideal halftone images.

Image gradation correction control is started in response to a command from the printer board, and is initiated after image density correction control.

D. Detecting the Density

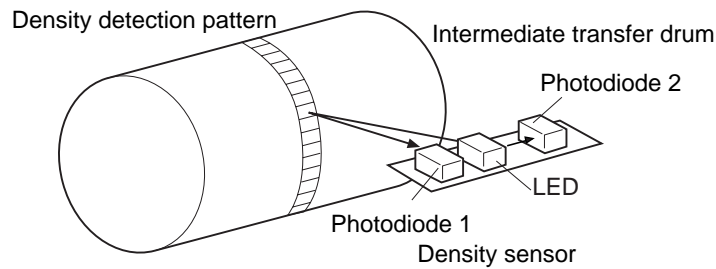

Figure 4-501

The density of the density detection pattern drawn on the intermediate transfer drum is checked by the density sensor. The density sensor is mounted on the density detection PCB; the light of a LED is directed to the density pattern on the intermediate transfer drum, and the reflected light is received by the photodiode 1.

The DC controller PCB generates the LED activation signal (LEDCNT) at such times as needed. The light from the LED is checked by the photodiode 2 directly, and the result is sent to the density detection circuit as the intensity feedback signal (DENREF), and is used to control the intensity of the LED to a specific level.

The light from the LED is also directed to the density detection pattern on the intermediate transfer drum, and the reflected light is directed to the photodiode 1.

The density detection PCB forwards the density signals to the DC controller PCB as the toner density detection signal (DNS). The DC controller PCB, in turn, converts the density detection signal (analog value) into density levels (digital value) for storage in memory.

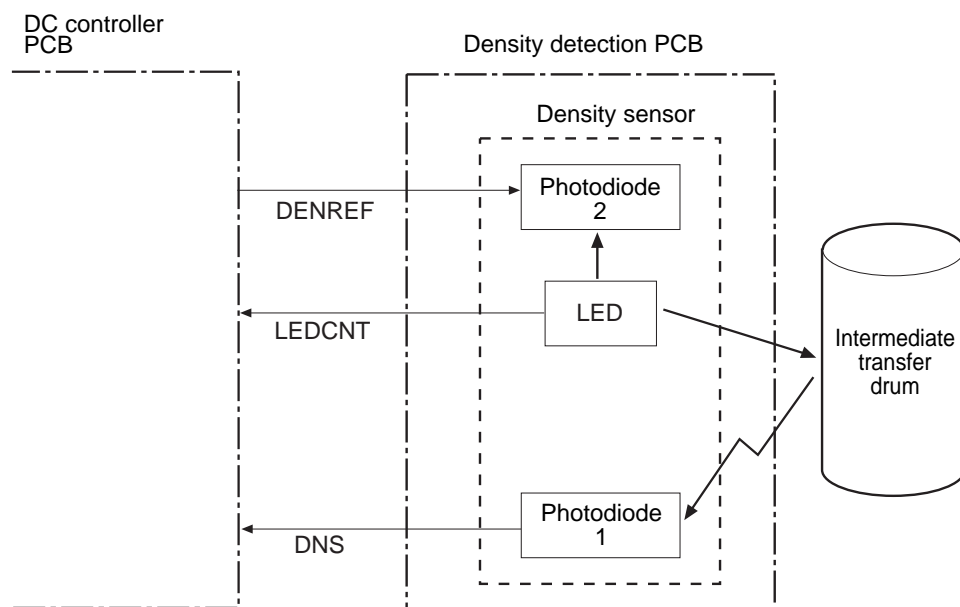

Figure 4-502

VI. HIGH-VOLTAGE POWER SUPPLY CIRCUIT

A. Outline

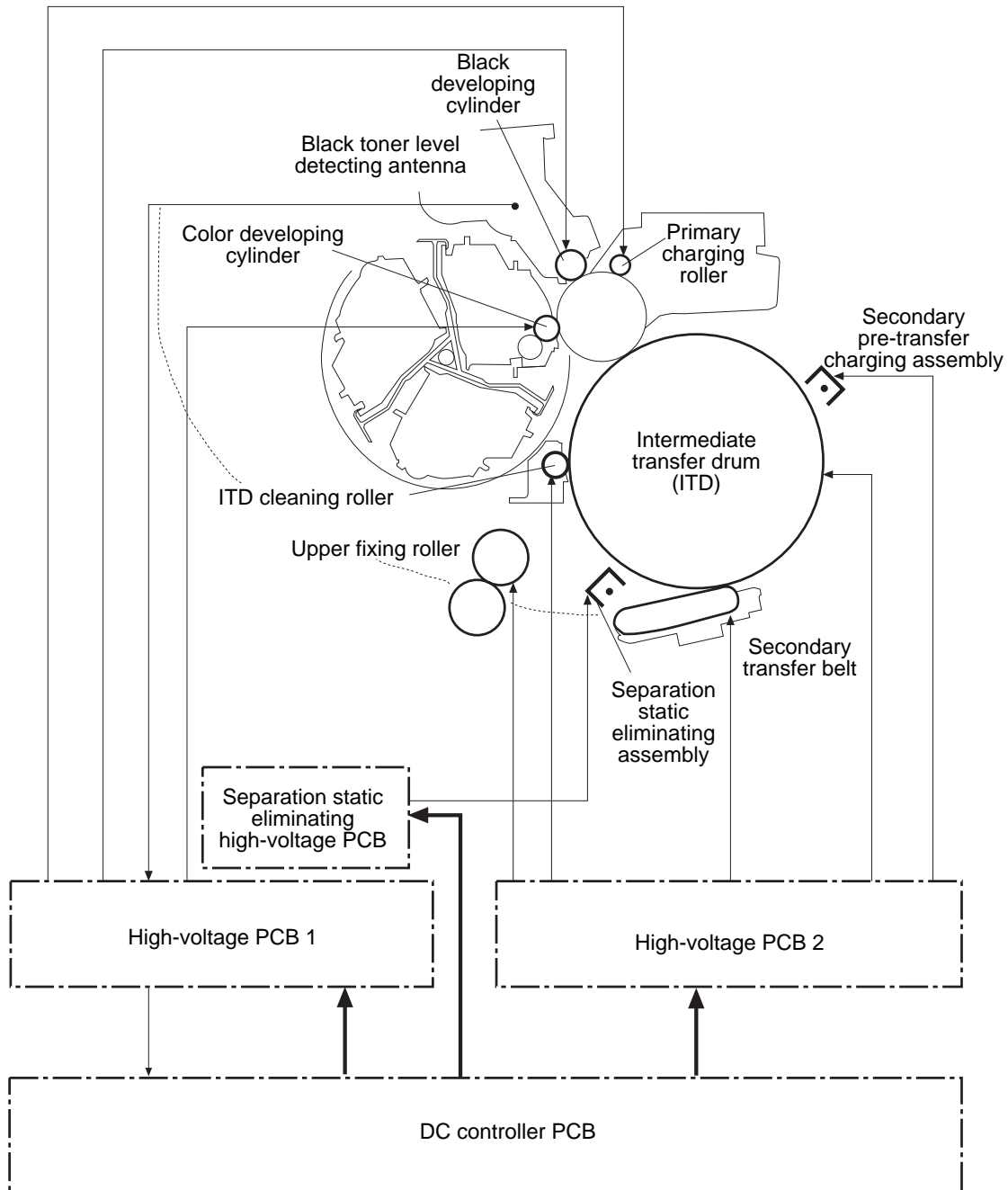

Figure 4-601

1. Primary Transfer Bias Generation Circuit

This circuit is controlled by three signals (Figure 4-602) generated by the DC controller PCB, and generates the primary transfer DC (positive) bias and primary transfer DC (negative) bias for application to the intermediate transfer drum.

The primary transfer DC (positive) bias drive signal turns on and off the DC (positive) bias applied to the intermediate transfer drum. The primary transfer DC (negative) bias drive signal, on the other hand, is used to turn on and off the DC (negative) bias applied to the intermediate transfer drum.

The primary transfer bias level control is used to switch the levels of the primary transfer DC (positive) bias. (See Note.)

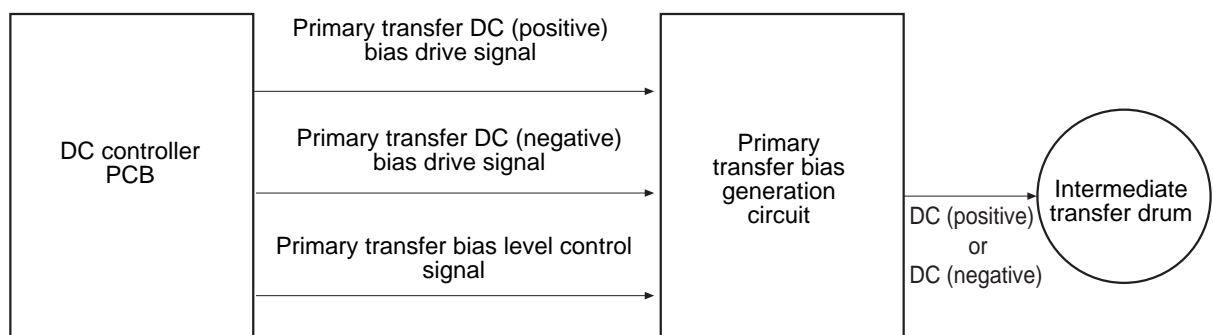

Figure 4-602

Note:

The level of the primary transfer DC (positive) bias differs between mono-color printing and full-color printing.

In the case of full-color printing, four color toners are deposited on the intermediate transfer drum for primary transfer; as such, the toner with negative charges increases for the second and subsequent colors, requiring increased transfer strength. To this end, the copier increases the primary transfer bias DC component when it deals with the second and subsequent colors.

The copier's high-voltage circuit consists of three PCBs; i.e., high-voltage PCB 1, high-voltage PCB 2, and separation static elimination high-voltage PCB. These PCBs are controlled by the DC controller PCB, and each in turn controls the following:

- High-voltage PCB 1: primary charging roller, black/color developing cylinder
- High-voltage PCB 2: intermediate transfer drum, ITD cleaning roller, secondary transfer belt, secondary pre-transfer charging assembly, upper fixing roller
- Separation static elimination high-voltage PCB: paper after secondary transfer

The DC controller PCB sets the various high-voltage levels and pulse outputs of reference frequency, and turns on and off the various high-voltage loads.

B. High-Voltage PCB 1

The high-voltage power supply PCB 1 consists of the following three circuits:

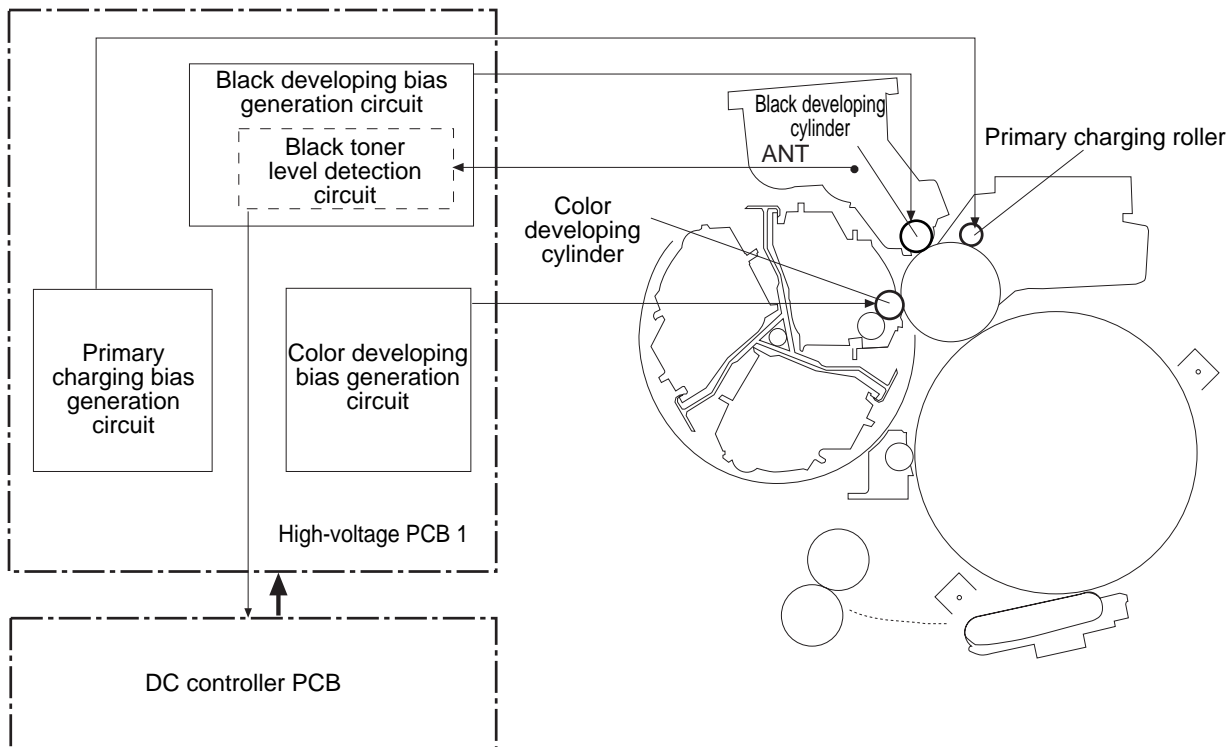

Figure 4-603

1. Primary Charging Bias Generation Circuit

This circuit is controlled by three signals (Figure 4-604) from the DC controller PCB, and generates primary charging DC bias and primary charging AC bias for application to the primary charging roller.

The primary charging AC bias is used to turn on and off the AC bias applied to the primary charging roller, while the primary charging DC bias drive signal is used to turn on and off the DC bias applied to the primary charging roller.

The primary charging bias level control signal is used to switch the levels of the primary charging DC bias for image areas.

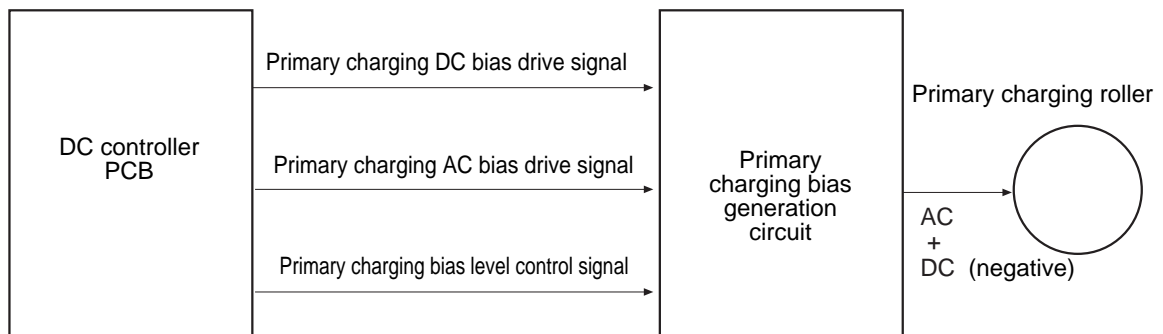

Figure 4-604

Note:

The primary charging DC bias level for image areas is varied in conjunction with the developing DC bias of each color according to the density adjustment command from the printer board*¹ or based on the result of image density correction control (p. 4-21).

*¹ Reader controller PCB (when making prints with the reader unit installed).

2. Color Developing Bias Generation Circuit

This circuit is controlled by three signals (Figure 4-605) from the DC controller PCB, and generates the color developing DC bias and color developing AC bias for application to the color developing cylinder.

The color developing AC bias drive signal is used to turn on and off the AC bias applied to the color developing cylinder, while the color developing DC bias drive signal is used to turn on and off the DC bias applied to the color developing cylinder.

The color developing bias level control signal, on the other hand, is used to switch the levels of the color developing DC bias for image areas.

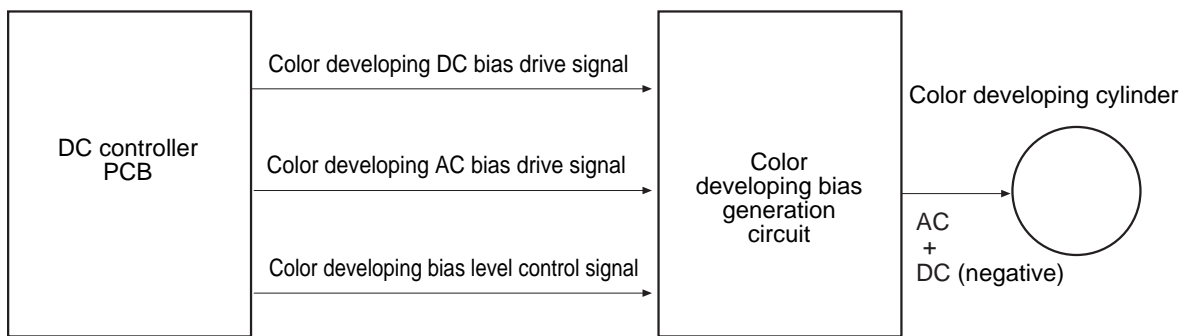

Figure 4-605

Note:

The color developing DC bias level for image areas is varied in response to the density command from the printer board*1 or based on the result of image density correction control (p. 4-21).

*1 Rear controller PCB (when making prints with the reader unit installed).

3. Black Developing Bias Generation Circuit

This circuit is controlled by three signals (Figure 4-606) from the DC controller PCB, and generates the black developing DC bias and black developing AC bias for application to the black developing cylinder.

The black developing AC bias drive signal is used to turn on and off the AC bias applied to the black developing cylinder, while the black developing DC bias drive signal is used to turn on and off the DC bias applied to the black developing cylinder.

The black developing bias level control signal, on the other hand, is used to switch the levels of the black developing DC bias. (See Note.)

The black developing bias generation circuit contains the black toner level detection circuit, which compares the output of the black developing AC bias and the output of the antenna mounted inside the cartridge for output to the DC controller PCB as the black toner level detection signal.

The DC controller PCB checks the voltage of the black toner level detection signal to find out the level of toner when the black developing AC bias is applied to the black developing cylinder.

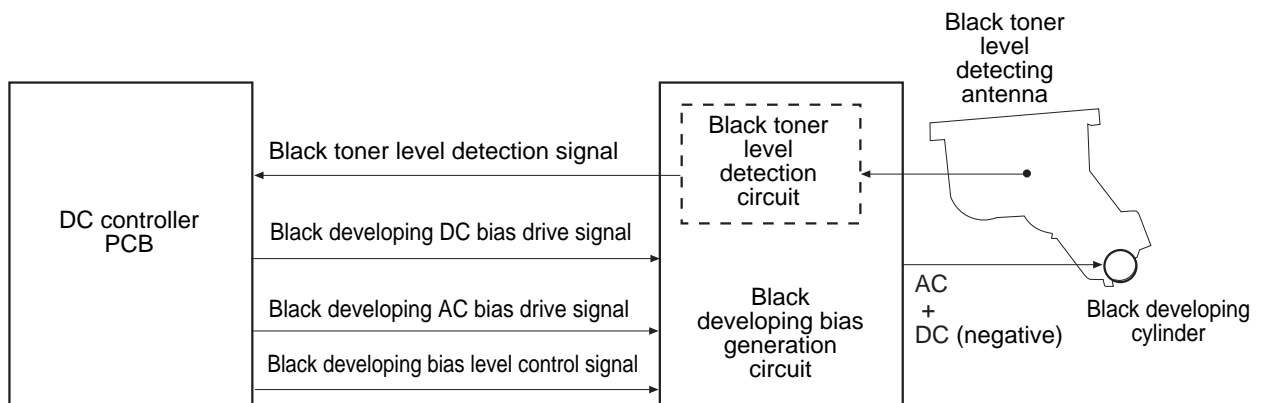

Figure 4-606

Note:

The black developing DC bias level for image areas is varied in response to the density command from the printer board*1 or based on the result of image density correction control (p. 4-21).

*1 Rear controller PCB (when making prints with the reader unit installed).

C. High-Voltage PCB 2

The high-voltage power supply PCB 2 consists of the five circuits shown in Figure 4-607.

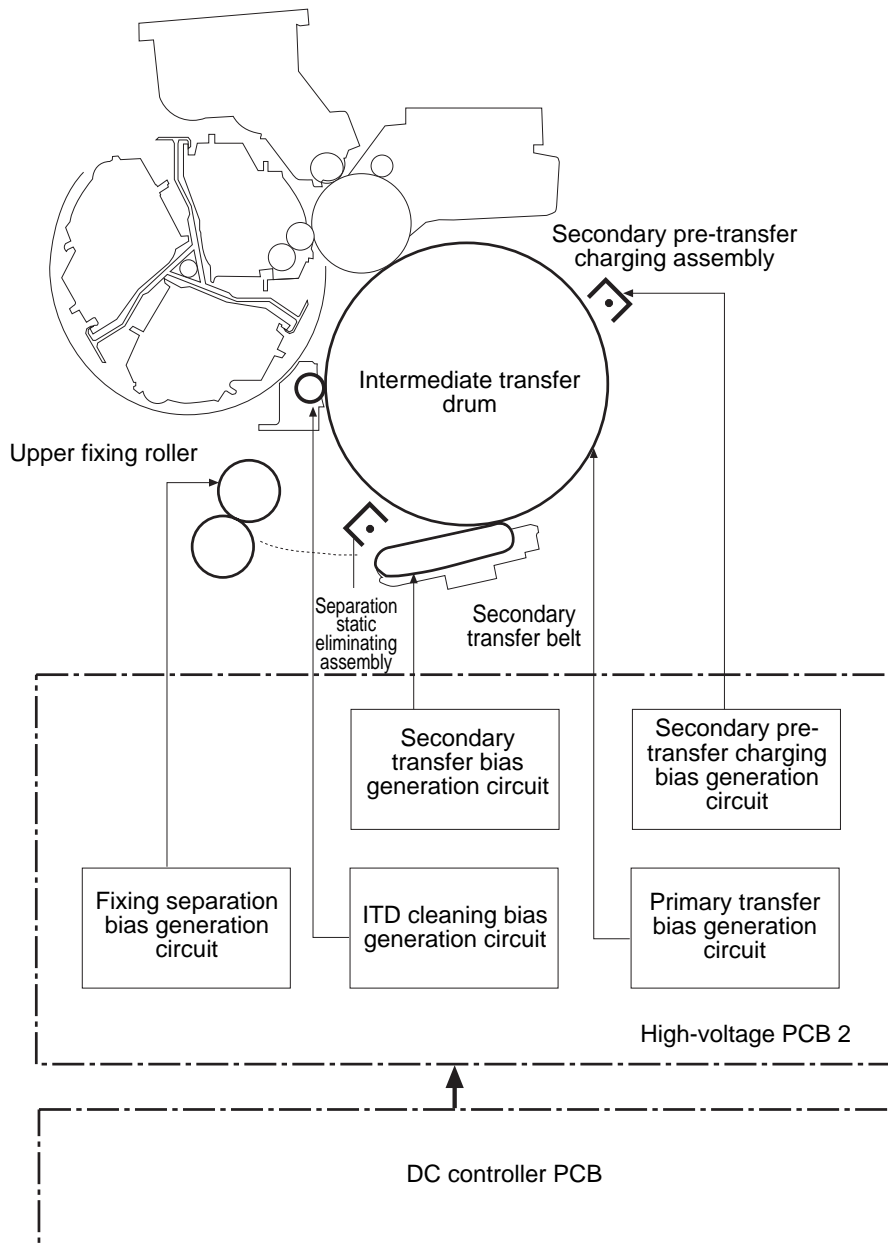

Figure 4-607

1. Secondary Pre-Transfer Charging Bias Generation Circuit

This circuit consists of three signals (Figure 4-6y08) from the DC controller PCB, and generates the secondary pre-transfer charging DC bias and the secondary pre-transfer AC bias for application to the secondary pre-transfer charging assembly.

The application voltage to the secondary pre-transfer charging assembly is turned on and off by the secondary pre-transfer DC bias drive signal and the secondary pre-transfer charging AC bias drive signal. The secondary pre-transfer charging bias signal is used to switch the level of the secondary pre-transfer charging DC bias according to environmental conditions.

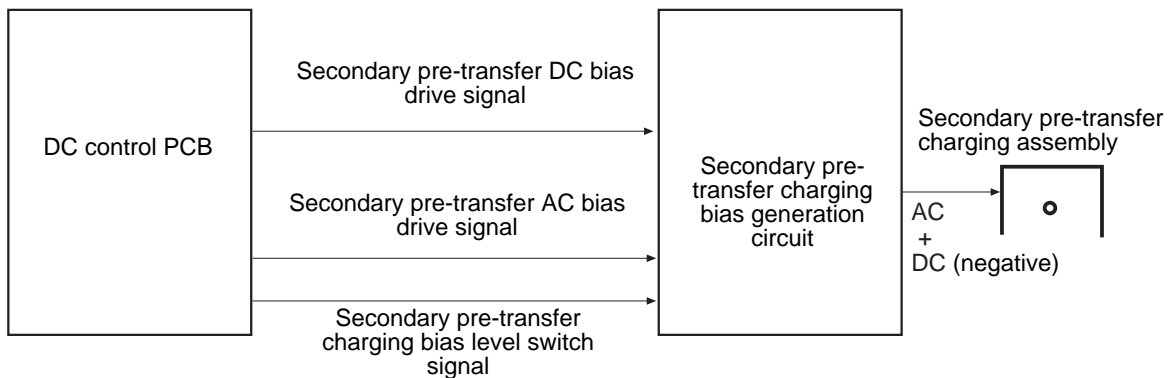

Figure 4-608

2. Secondary Transfer Bias Generation Circuit

This circuit is controlled by four signals (Figure 4-609) from the DC controller PCB, and generates the secondary transfer DC (positive) bias and the secondary transfer DC (negative) bias for application to the secondary transfer belt.

The secondary transfer DC (positive) bias drive signal is used to turn on and off the DC (positive) bias applied to the secondary transfer belt, while the secondary DC (negative) bias drive signal is used to turn on and off the DC (negative) bias applied to the secondary transfer belt.

The secondary transfer bias level (constant current) control signal and the secondary transfer bias level (constant voltage) control signals are bias level switch signals, and are used to switch the secondary transfer DC (positive) bias according to the type of paper and the conditions of the environment.

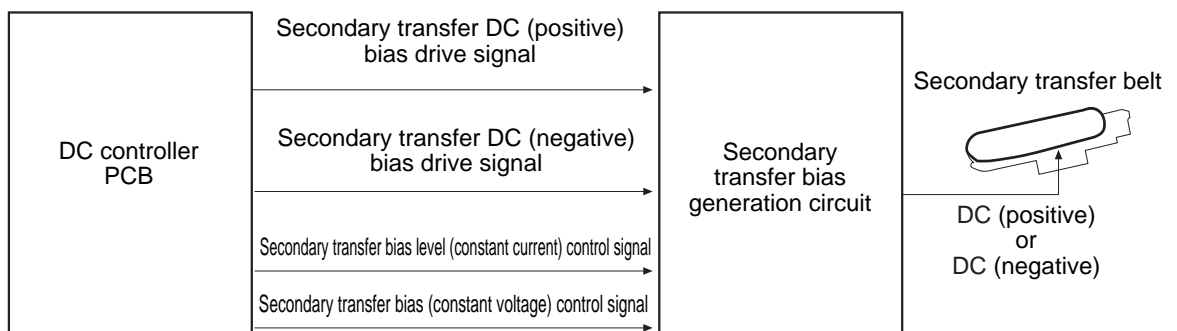

Figure 4-609

3. ITD Cleaning Bias Generation Circuit

This circuit is controlled by four signals (Figure 4-610) from the DC controller PCB, and generates the ITD cleaning DC (positive) bias, ITD cleaning DC (negative) bias, and ITD cleaning AC bias for application to the ITD cleaning roller.

The ITD cleaning DC (positive) bias drive signal is used to turn on and off the DC (positive) bias applied to the ITD cleaning roller, while the ITD cleaning DC (negative) bias drive signal is used to turn on and off the DC (negative) bias applied to the ITD cleaning roller.

The ITD cleaning AC bias drive signal, on the other hand, is used to switch the ITD cleaning AC bias level to suit the conditions of the environment.

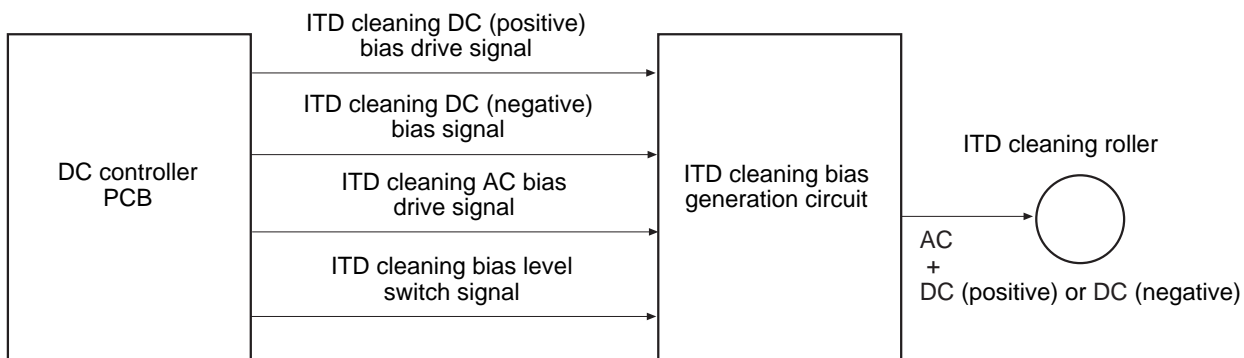

Figure 4-610

4. Fixing Separation Bias Generation Circuit

This circuit is controlled by the fixing separation DC bias drive signal from the DC controller PCB, and generates the fixing separation DC bias for application to the upper fixing roller.

The voltage applied to the upper fixing roller is controlled by the fixing separation DC bias drive signal. The level of the fixing separation DC bias, further, is kept to a specific level.

D. Separation Static Eliminating Bias PCB

This circuit is controlled by two signals (Figure 4-611) from the DC controller PCB, and generates the separation static eliminating DC bias and the separation static eliminating AC bias for application to the separation static eliminating assembly.

The voltage applied to the separation static eliminating assembly is turned on and off by the separation static eliminating DC bias drive signal and the separation static eliminating AC bias drive signal. The level of the biases (both AC and DC) is kept to a specific level.

The DC controller PCB generates the separation static eliminating AC bias drive signal to suit the type of paper and the conditions of the environment.

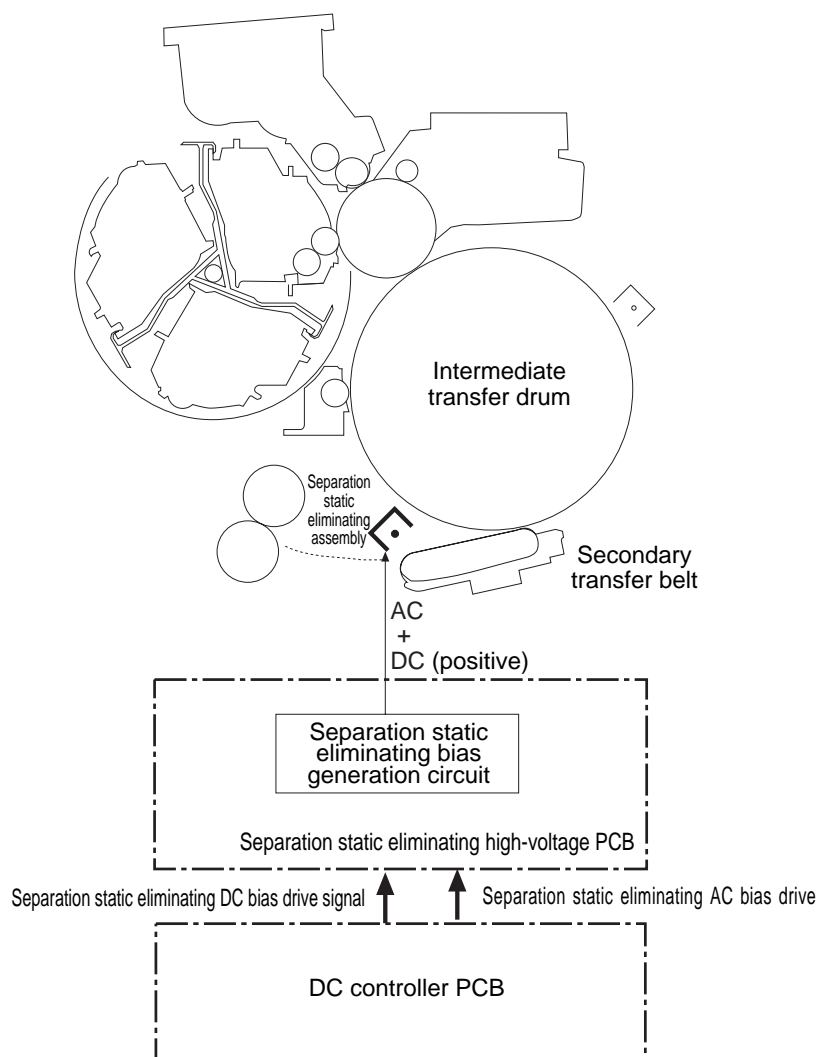

Figure 4-611

VII. OTHER CONTROL MECHANISMS

A. Developing Rotary Motor Control

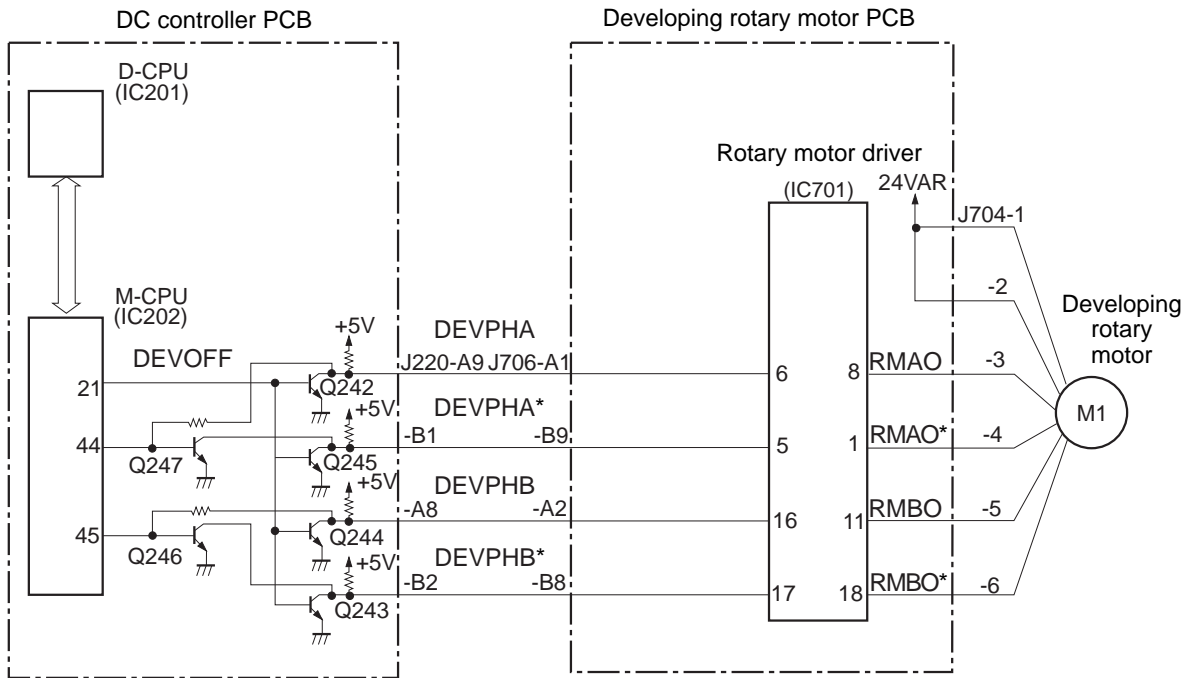

Figure 4-701

The developing rotary motor is a 2-phase stepping motor, controlled by the rotary motor driver (IC701) on the developing rotary motor PCB, and is used to rotate the developing rotary.

In response to a print sequence command from the D-CPU (IC202), the M-CPU (IC201) sends the developing rotary motor control signals (DEVPHA, DEVPHA*, DEVPHB, DEVPHB*) to the rotary motor driver (IC701) on the developing rotary motor PCB.

The rotary motor driver uses these signals to send drive signals (RMAO, RMAO*, RMBO, RMBO*) to the developing rotary motor, switching the motor between normal and low-speed rotation modes.

The motor torque would fluctuate according to the speed of the motor, requiring variation of the current level.

	Rotation speed
Detection of home position or shift to cartridge removal position	Low-speed
Other than above	Normal

Table 4-701

B. Controlling the Cartridge Motor

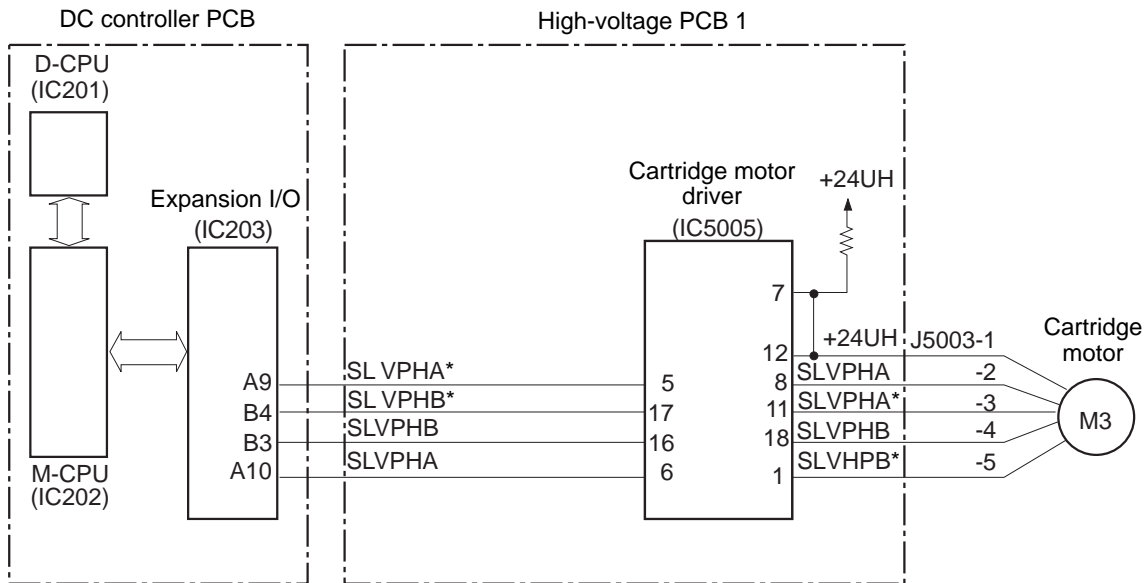

Figure 4-702

The cartridge motor is a 2-phase stepping motor, and is controlled by the cartridge motor driver (IC5001) on the high-voltage PCB 1 to drive the developing cylinder of the color toner cartridge and the developing cylinder.

In response to a print sequence command from the D-CPU (IC202), the M-CPU (IC201) sends the cartridge motor control signals (SLVPHA, SLVPHA*, SLVPHB, SLVPHB*) to IC5005 on the high-voltage PCB through the expansion I/O (IC203).

IC5005 uses these signals to supply the motor with drive signals (SLVPHA, SLVPHA*, SLVPHB, SLVPHB*) to rotate the developing cylinders of the color toner cartridges and the black toner cartridges.

The machine's drive gear arrangement would cause the developing cylinder of the color toner cartridges and the developing cylinder of the black toner cartridge to rotate in opposite directions if the cartridge motor was rotated in a single direction. To avoid this, IC5005 rotates the motor clockwise when the color toner cartridge is used, while it rotates the motor counterclockwise when the black toner cartridge is used.

C. Controlling the Drum Motor

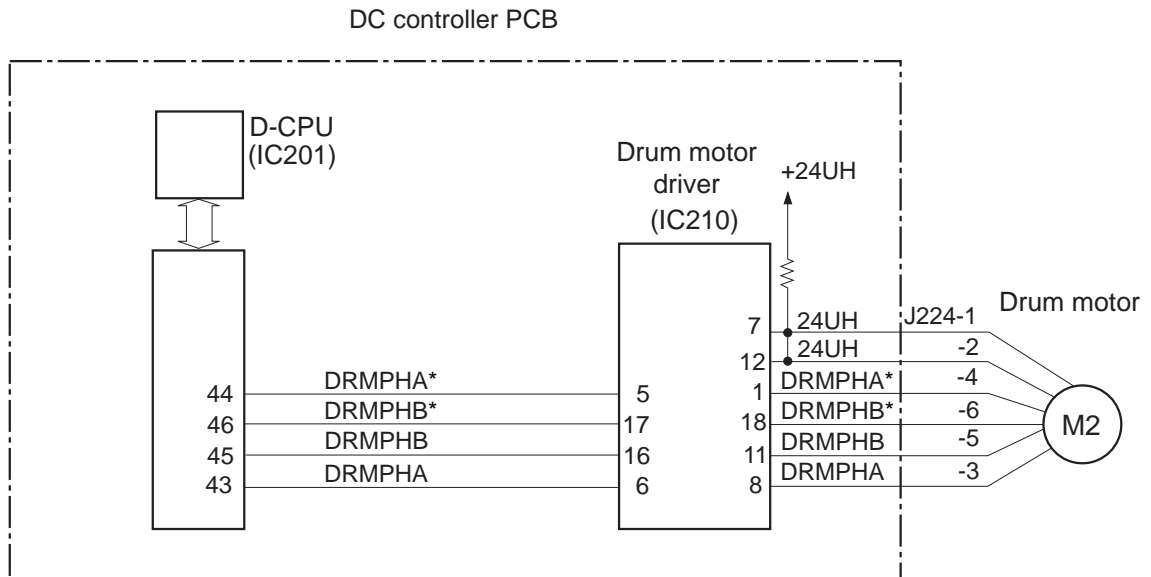

Figure 4-703

The drum motor is a 2-phase stepping motor, and is controlled by the drum motor driver (IC210) to drive the intermediate transfer drum and the photosensitive drum.



In response to a print sequence command from the D-CPU (IC202), the M-CPU (IC201) sends drum motor drive signals (DRMPHA, DRMPHA*, DRMPHB, DRMPHB*) to the drum motor driver (IC210).

IC210 uses these signals to supply the motor with drive signals (DRMPHA, DRMPHA*, DRMPHB, DRMPHB*), thereby rotating the intermediate transfer drum and the photosensitive drum.

In transparency mode and thick paper mode, the drum motor is rotated at low speed (1/4 for transparency mode, 1/3 for thick paper mode) to slow down the movement of paper through the fixing assembly.

VIII. DISASSEMBLY/ASSEMBLY

Make sure of the following when disassembling or assembling the machine:

1.  When the printer unit power switch is turned off, the fans will operate for about 30 min to cool the machine (so as to prevent caking of toner). Be sure to perform either of the following in addition to disconnecting the power plug:
 - Wait for 30 min after turning off the printer unit power switch; or
 - Turn off the printer unit power switch, and remove the fixing assembly of the printer unit.
2. Assemble the parts by reversing the steps used to disassemble them, unless otherwise mentioned.
3. Identify the screws by type (length, diameter) and location.
4. Do not leave out the toothed washer that comes with one of the mounting screws on the rear cover to protect against static electricity.
5. Do not leave out the washer that comes with the screw used for the grounding wire and the varistor to ensure electrical continuity.
6. Do not operate the machine with any of its parts removed, unless otherwise mentioned.
7.  Do not throw a toner cartridge into fire. It may explode.
8. Keep any toner cartridge in a protective cover whenever it has been taken out of the copier for disassembly/assembly work even for a short time.
9. Remove the cartridge and the intermediate transfer drum before disassembly/assembly work or moving the machine.
10. Touch the machine's metal section before starting the work to discharge the build-up of static electricity so as to prevent static damage before handling any PCBs.
11. To slide out the printer unit from the rack (if the reader unit is also mounted to the rack), pull halfway out the two side pins at the bottom of the rack (middle pin orientation *), and then remove the printer unit fixing member from the left of the copier. Be sure also to remove the printer side power cord and the interface cable.

For removal of the external covers of the printer unit, see IV.A. "External Covers of the Printer Unit" in Chapter 3.

A. Drive System

1. Removing the Drum Drive Unit

- 1) Perform steps 1) through 7) on p. 4-43 to remove the upper cover, rear cover, shielding box, heat discharge fan 1, and rear cover stay.
- 2) Perform step 2) on p. 4-56 to remove the high-voltage PCB 1.
- 3) Perform step 3) on p. 4-55 to remove the DC controller PCB.
- 4) Perform step 2) on p. 4-58 to remove the high-voltage PCB 2.
- 5) Perform step 3) on p. 4-58 to remove the sub transfer 2.
- 6) Perform step 3) on p. 4-58 to remove the sub transformer 1.
- 7) Perform step 2) on p. 4-60 to remove the color toner cartridge level sensor.
- 8) Remove the eight screws, and disconnect the connector; then, remove the drum drive assembly.

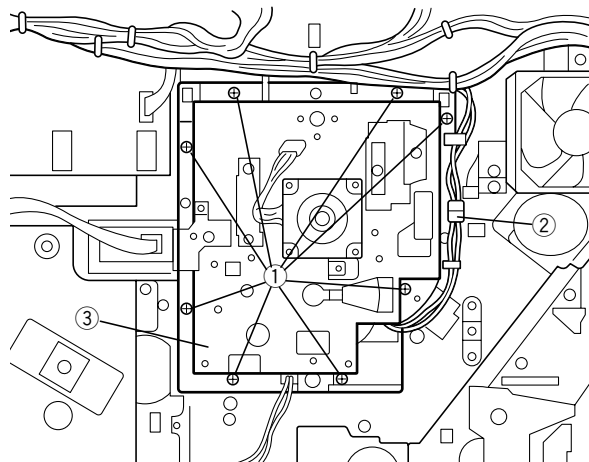

- ① Screws ② Connector
 ③ Drum drive assembly

Figure 4-801

Caution:

When the drum drive assembly is mounted, the gear of the drive assembly and the flags of the developing rotary assembly can interfere with each other, breaking the flags. To avoid this problem, be sure to move the flags of the developing rotary assembly so that they are out of view inside the copier before mounting the drum drive assembly.

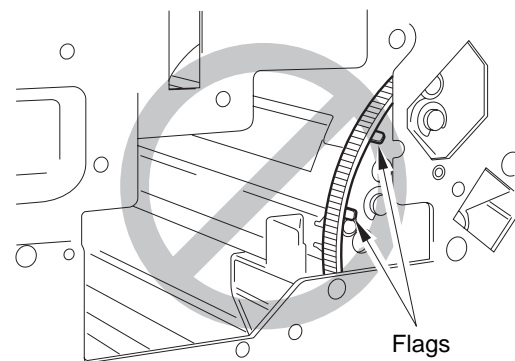

2. Removing the Drum Motor

- 1) Remove the five screws, and detach the drive case.

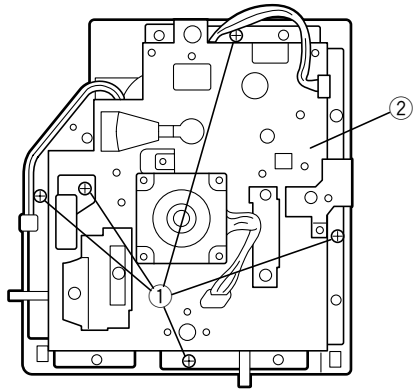

- ① Screws ② Drive case

Figure 4-802

3. Removing the Developing Rotary Position Sensor

- 1) Remove the screw, and detach the developing rotary position sensor.

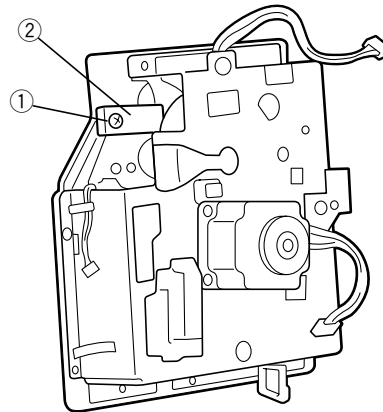

- ① Screw
② Developing rotary position sensor

Figure 4-804

- 2) Remove the drive gear shaft, and remove the four screws; then, detach the drum motor.

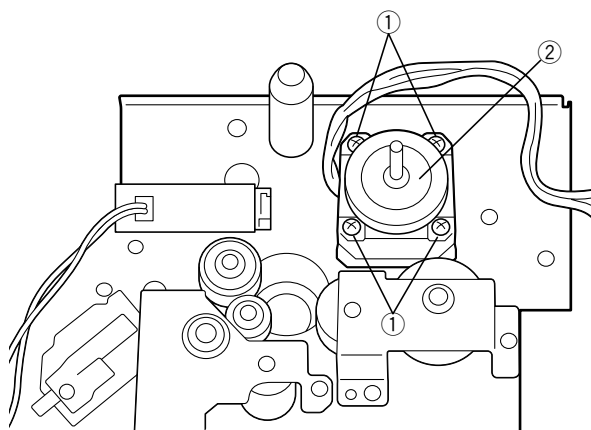

- ① Screw ② Drum motor

Figure 4-803

4. Removing the Delivery Drive Assembly

- 1) Perform steps 1) through 7) on p. 4-43 to remove the upper cover, heat discharge fan 1, shielding box, and rear cover stay.
- 2) Perform step 2 of removing the developing rotary motor PCB to remove the PCB.
- 3) Remove the two screws, and detach the duct cover.

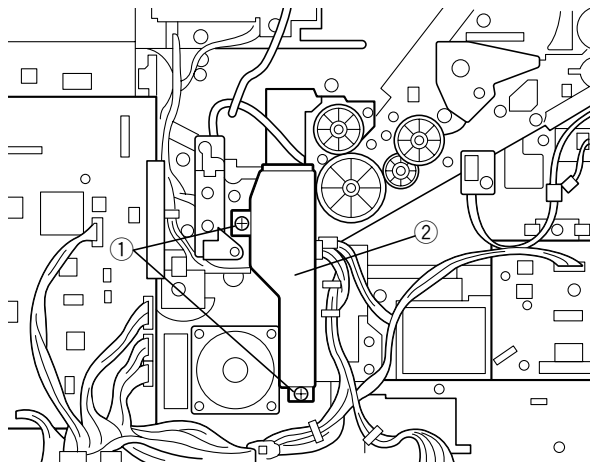

- ① Screws ② Duct cover

Figure 4-805

- 4) Remove the screw, and detach the gear cover.

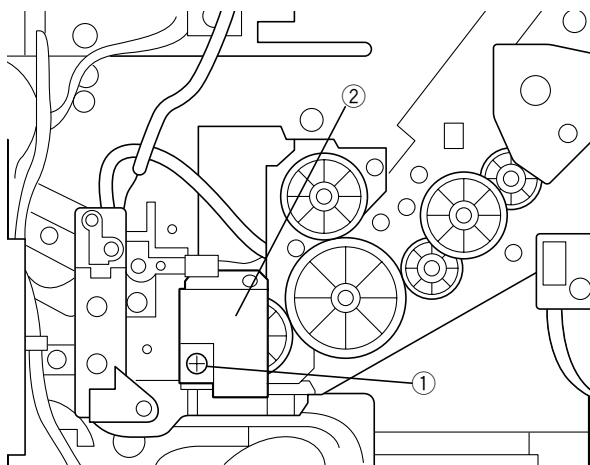

- ① Screw ② Gear cover

Figure 4-806

- 5) Remove the seven screws, and detach the delivery drive assembly.

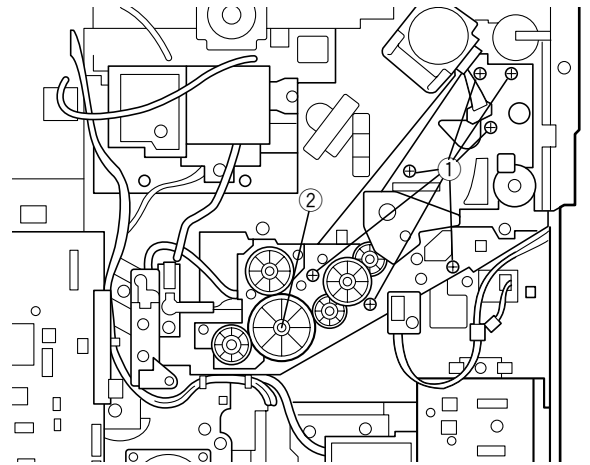

- ① Screws
② Delivery drive assembly

Figure 4-807

5. Removing the Main Drive Assembly

- 1) Perform the steps on p. 5-35 to remove the pick-up assembly.
- 2) Remove the steps on p. 3-21 to remove the inside covers 1, 3, and 4.
- 3) Perform the steps on p. 4-43 to remove the main motor.
- 5) Disengage the two claws, and detach the gear cover.

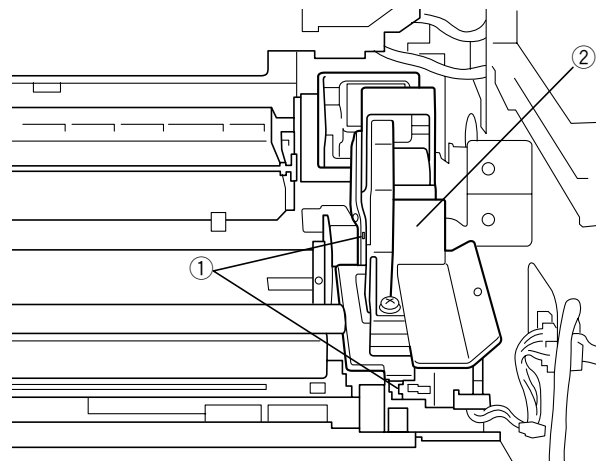

- ① Claws ② Gear cover

Figure 4-808

- 6) Remove the E-shaped stop ring and the bushing.

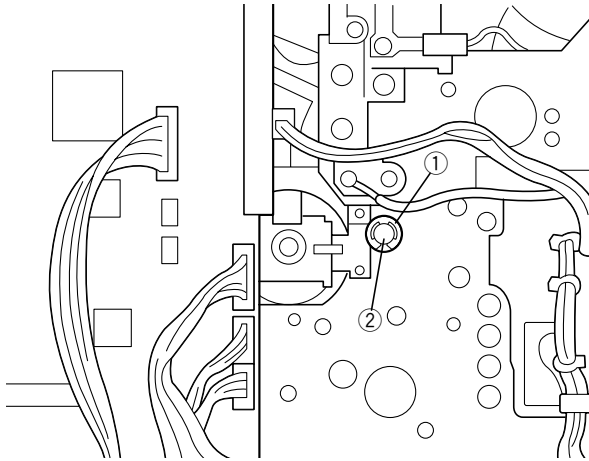

- ① E-shaped stop ring ② Bushing

Figure 4-809

- 7) Remove the E-shaped stop ring and the bushing; then, detach the releasing lever 2.

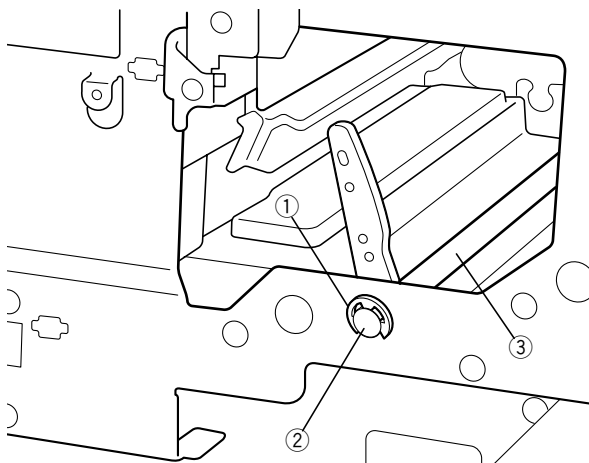

- ① E-shaped top ring ② Bushing
③ Shaft of the releasing lever 2

Figure 4-810

- 8) Remove the screw, and disconnect the connector; then, remove the metal fixing and the secondary transfer belt clutch.

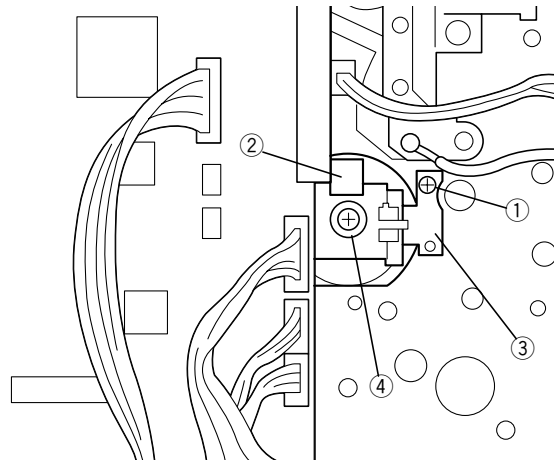

- ① Screw
② Connector
③ Metal fixing
④ Secondary transfer belt clutch

Figure 4-811

- 9) Remove the two screws, and detach the main drive assembly.

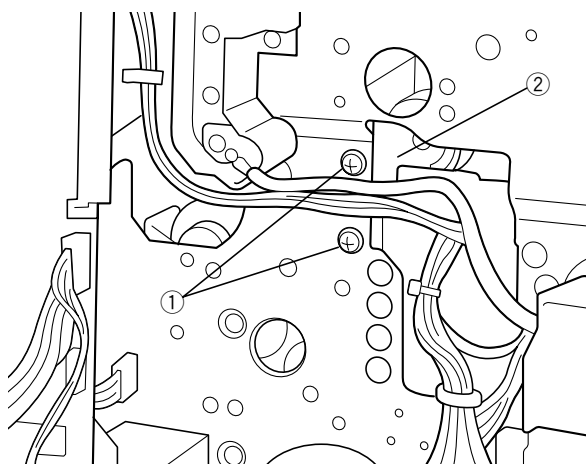

- ① Screw
② Main drive assembly

Figure 4-812

6. Removing the Main Motor

- 1) Perform the steps on p. 4-55 to remove the DC controller PCB.
- 2) Remove the four screws, and disconnect the connector; then, detach the main motor.

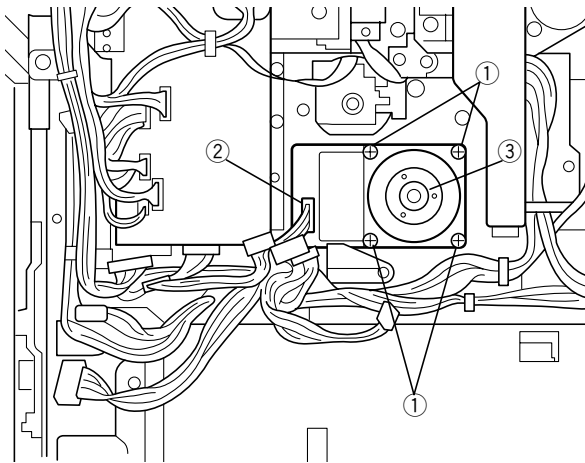

- ① Screws
- ② Connector
- ③ Main motor

Figure 4-813

8. Developing Rotary Motor

- 1) Perform the steps on p. 3-14 to remove the upper cover.
- 2) Perform the steps on p. 3-16 to remove the rear cover.
- 3) Remove the four screws, and disconnect the two connectors on the DC controller PCB to detach; then, detach the video interface PCB.

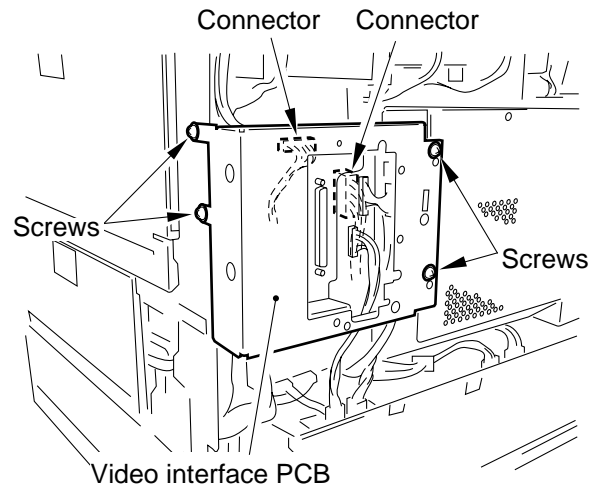
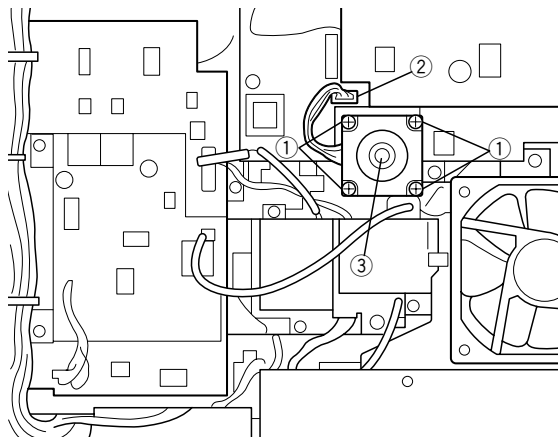

Figure 4-815

7. Removing the Cartridge Motor

- 1) Perform the steps on p. 3-16 to remove the rear cover assembly.
- 2) Remove the four screws, and disconnect the connector; then, detach the cartridge motor.



- ① Screws
- ② Connector
- ③ Cartridge motor

Figure 4-814

- 4) Remove the five screws.

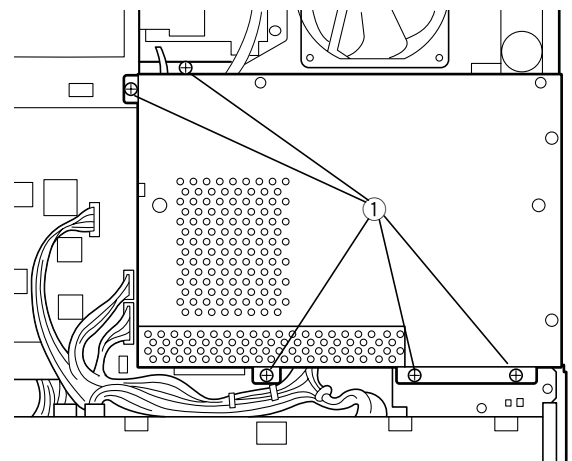

- ① Screws

Figure 4-816

- 5) Remove the five screws, and detach the shielding box.

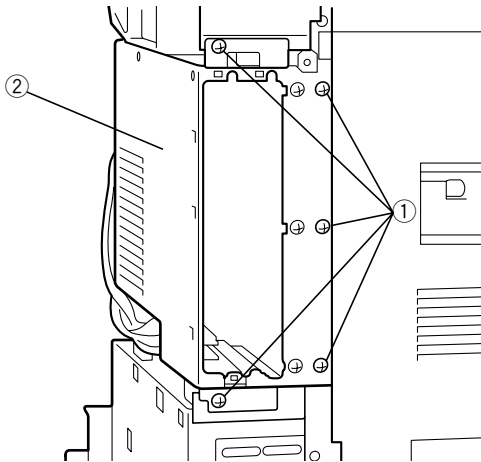

- ① Screws
- ② Shielding box

Figure 4-817

Note: Take care not to bend the grounding spring found on both ends of the shielding box.

- 6) Remove the four screws, and disconnect the connector; then, detach the heat discharge fan 1 (FM1) together with its holder.

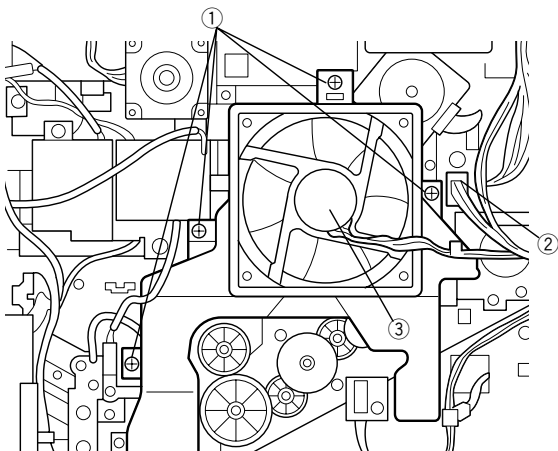

- ① Screws
- ② Connector
- ③ Heat discharge fan 1

Figure 4-818

- 7) Remove the five screws, and detach the rear cover stay.

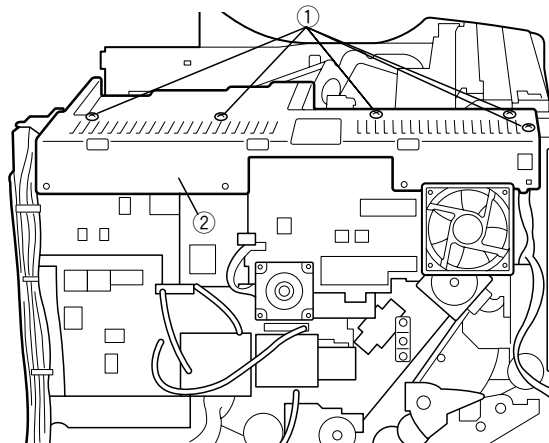

- ① Screws
- ② Rear cover stay

Figure 4-819

- 8) Remove the screw, and disconnect the connector; then, remove the cable clamp, and detach the heat discharge fan 2 (FM2) together with its holder.

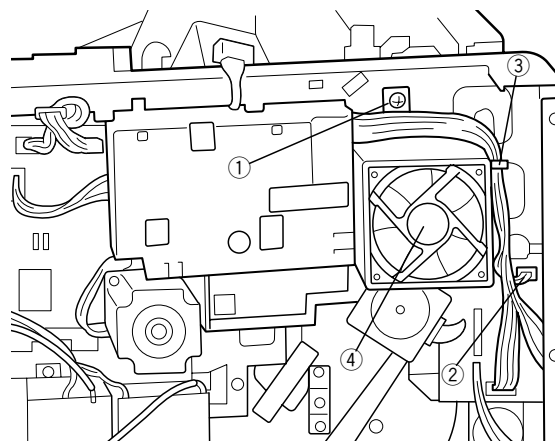

- ① Screw
- ② Connector
- ③ Cable clamp
- ④ Heat discharge fan 2

Figure 4-820

- 9) Remove the four screws, and disconnect the connector; then, remove the developing rotary motor.

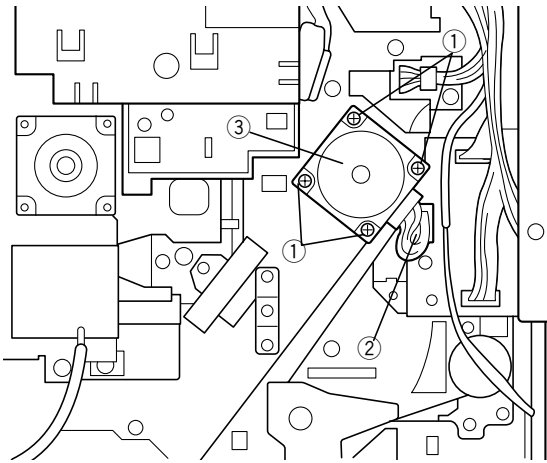

- ① Screws ② Connector
③ Developing rotary motor

Figure 4-821

B. Charging, Developing, and Cleaning

1. Removing the Intermediate Transfer Drum

- 1) Open the front cover of the machine's printer unit; while pushing the lock button on the releasing lever, push down the lever in lower right direction until it stops (thereby, unlocking the intermediate transfer drum).

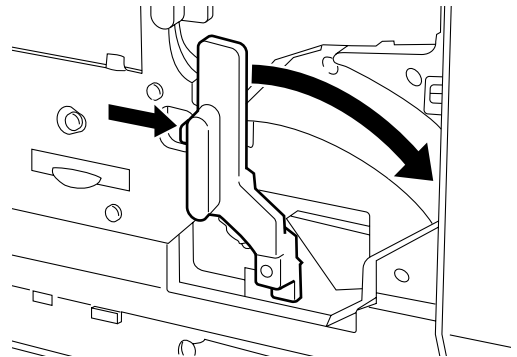

Figure 4-822

- 2) Open the right cover.

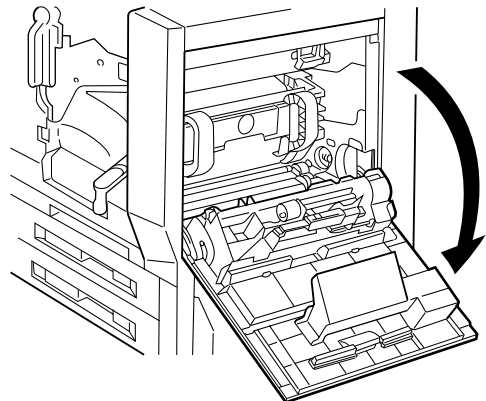

Figure 4-823

- 3) While holding the left and right levers of the intermediate transfer drum, pull the drum straight; when it stops, remove it as if to lift it at an angle.

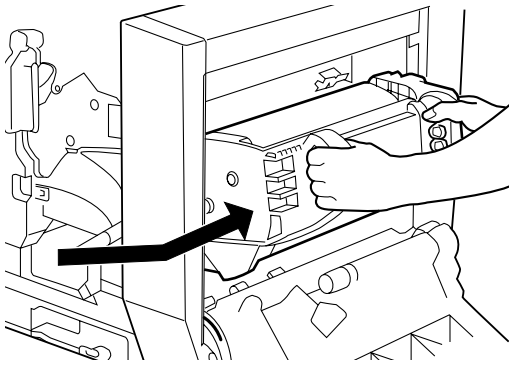

Figure 4-824

Note: The intermediate transfer drum is heaviest at the rear. Remove it as if to lift its rear.

2. Mounting a New Immediate Transfer Drum

- 1) Remove the protective sheet from the new intermediate transfer drum as shown.

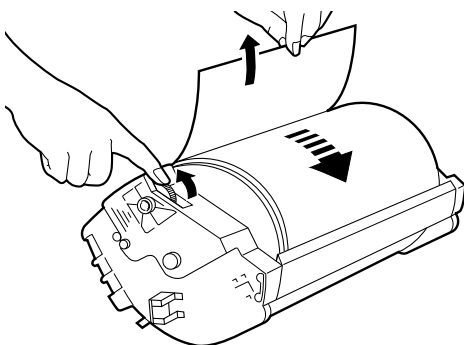

Figure 4-825

Note: Take care not to scratch the surface of the intermediate transfer drum. Avoid touching it.

- 2) Mount the intermediate transfer drum by reversing the steps used to remove it.

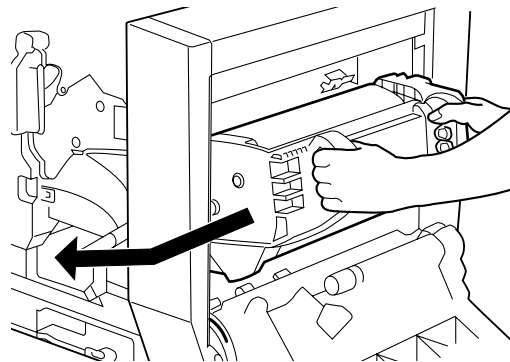

Figure 4-826

- 3) Shift back the bottom releasing lever of the front cover to close the cover.

Note: The intermediate transfer drum must be mounted correctly to set the bottom releasing lever.

- 4) Close the right cover and the front cover.

3. Removing the Pre-Transfer Charging Assembly from the Intermediate Transfer Drum

- 1) Remove the two screws, and detach the secondary pre-transfer charging assembly from the intermediate transfer drum.

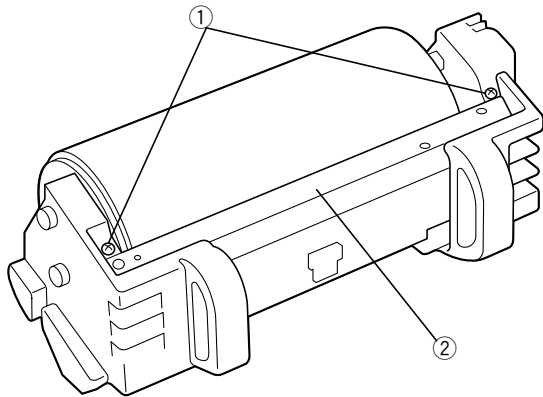

- ① Screws
- ② Secondary pre-transfer charging assembly

Figure 4-827

Note:

1. Be sure to place the intermediate transfer drum on a level surface. Use paper under the drum.
2. Do not clean the intermediate transfer drum. If absolutely necessary, wipe its surface with a flannel cloth moistened with water, and then dry wipe it.

4. Color Cartridge and Print Image Faults

Normally, the color toner cartridges (Y, M, C) may be taken out and put back in easily. If any of them cannot be moved at all because of a power fault or the like, perform the following:

- 1) Open the front cover.
- 2) Perform the steps on p. 3-15 to remove the side cover.
- 3) Disengage the four claws, and remove the stopper arm cover.

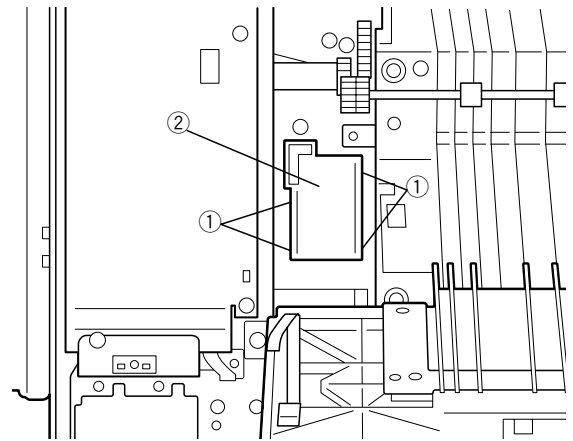

- ① Claws
- ② Stopper arm cover

Figure 4-828

- 4) Check to make sure that the developing rotary stopper arm is released; otherwise, pull the stopper to the front.

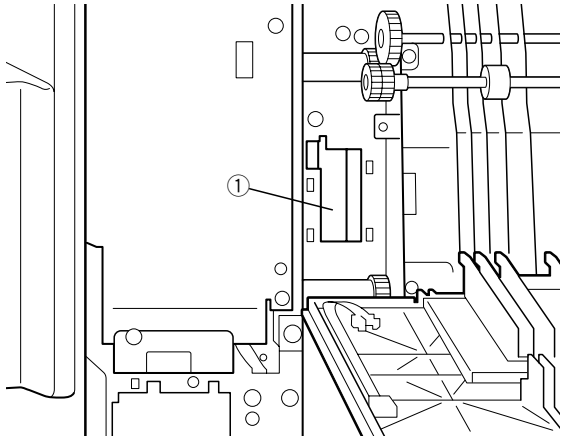

① Developing rotary stopper arm

Figure 4-829

- 5) Open the toner cartridge cover; then, put your hand through the slot of the color toner cartridge, and rotate the developing rotary assembly clockwise slowly.

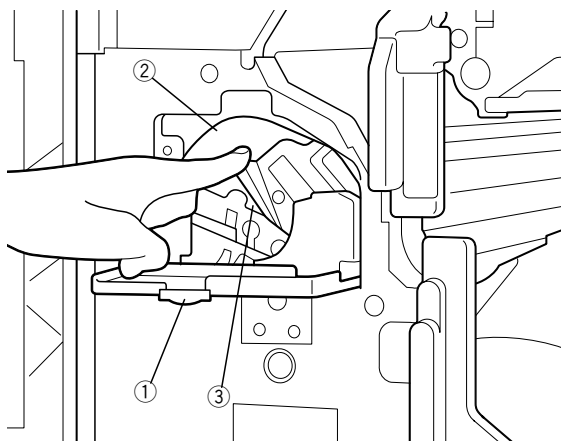

① Toner cartridge cover
 ② Color toner cartridge slot
 ③ Developing rotary assembly

Figure 4-830

Note: When rotating the developing rotary assembly, do not hold the releasing lever. Be sure to hold the metal area of the developing rotary assembly.

- 6) When the slot of the color toner cartridge and the position of the color toner cartridge match, shift the releasing lever in the direction of the arrow.

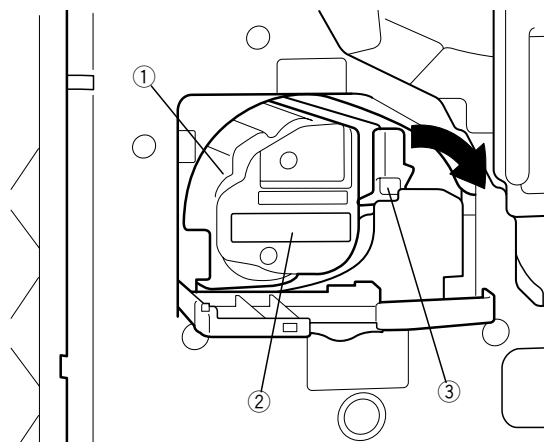
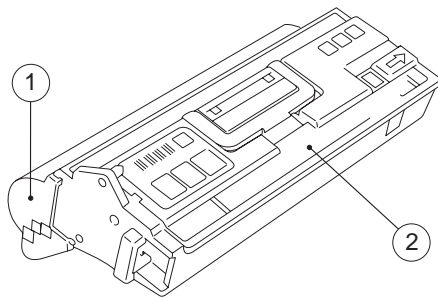

Figure 4-831

- 7) Take out the color toner cartridge. Then, perform the foregoing steps 4) through 5) twice to take out the three color toner cartridges.

5. Points to keep in Mind about Cartridges

- a. Photosensitive Drum Cartridges
- Be sure to wrap the photosensitive drum cartridges with a protective cover whenever it is taken out of the copier. If it must be left out of the copier for a long time, be sure to put it in a protective bag.
 - Work fast as when cleaning. Exposing the drum to light for a long time will affect print images.
 - As a rule, do not touch or clean the drum. If absolutely necessary, use a flannel cloth.
 - Do not use lint-free paper. It will damage the surface of the drum. Further, never use solvent.



- ① Protection cover
② Photosensitive drum

Figure 4-832

Note:

After replacing the drum cartridge, be sure to execute auto gradation correction.

- b. Bk Toner Cartridge
- Do not open the shutter of the Bk toner cartridge unnecessarily.
 - Put the Bk toner cartridge in a protective bag whenever it is taken out of the printer unit.

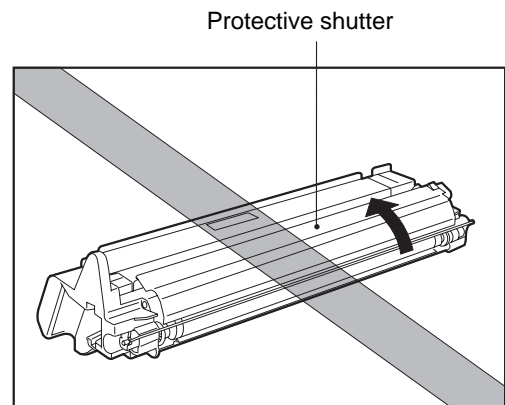

Figure 4-833

- c. Color Toner Cartridge
- Do not open the shutter of a color toner cartridge (Y, M, C) unnecessarily.
 - Put the color toner cartridge (Y, M, C) in a protective bag whenever it is taken out of the printer unit.

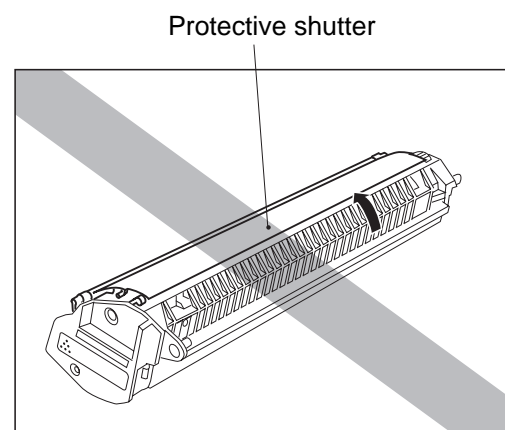
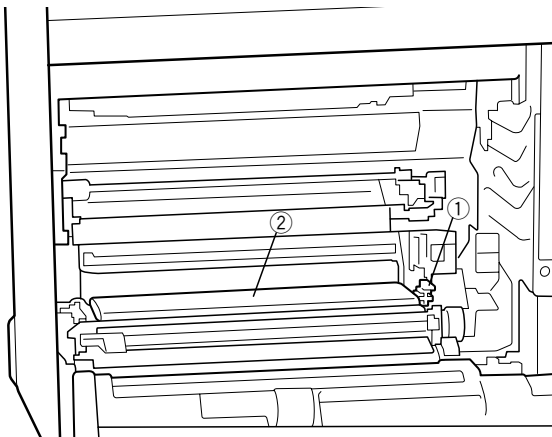

Figure 4-834

6. Removing the Secondary Transfer Belt Assembly

- 1) Open the right cover and the front cover.
- 2) Perform steps 2) and 3) on p. 4-52 to remove the separation static eliminator.
- 3) Perform the steps on p. 4-45 to remove the intermediate transfer drum.
- 4) Pull up the lever 90°, and detach the secondary transfer belt assembly.



- ① Lever
- ② Secondary transfer belt assembly

Figure 4-835

Note:

1. When replacing the secondary transfer belt assembly, take care not to touch the belt.
2. Do not clean the belt.
3. When removing the secondary transfer belt assembly, be sure to remove the separation static eliminator in advance.
4. After mounting a new secondary transfer belt assembly to the printer unit, be sure to remove the protective sheet wrapped around the belt assembly.

7. Removing the ITD Cleaning Holder Assembly

- 1) Perform the steps on p. 3-20, and detach the inside cover 1.
- 2) Open the right cover.
- 3) Remove the screw, and disconnect the connector; then, detach the ITD cleaning roller solenoid.

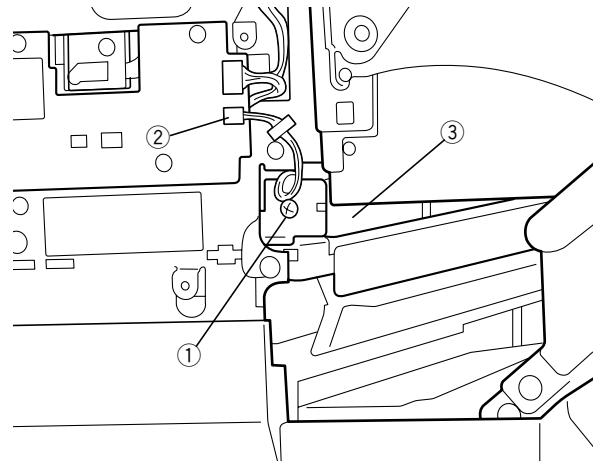

- ① Screw
- ② Connector
- ③ ITD cleaning roller solenoid

Figure 4-836

- 4) Using a high-accuracy screwdriver, free the two springs from the stay.

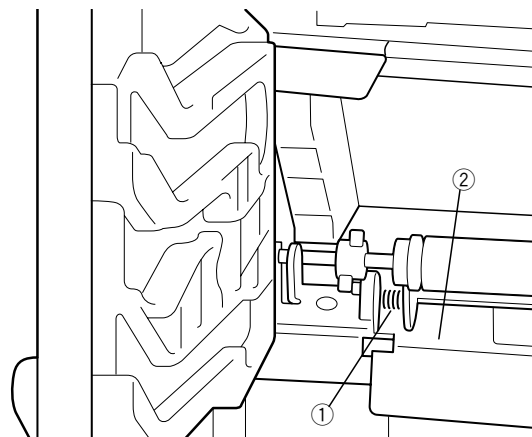

- ① Spring
- ② Stay

Figure 4-837

• Enlarged View of the Right End

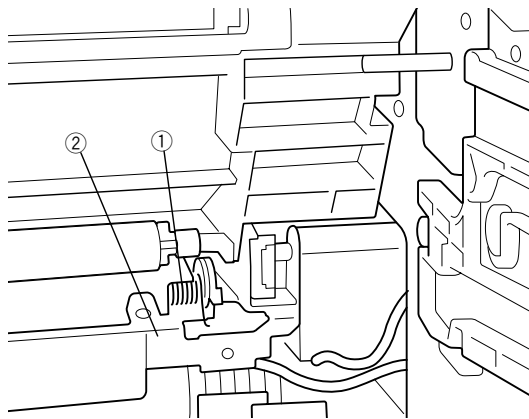

① Sprint ② Stay

Figure 4-838

- 5) Free the claw of the releasing knob found on the left end of the ITD cleaning holder assembly, turn the releasing knob in the direction of the arrow; then, match the boss of the releasing knob as shown.

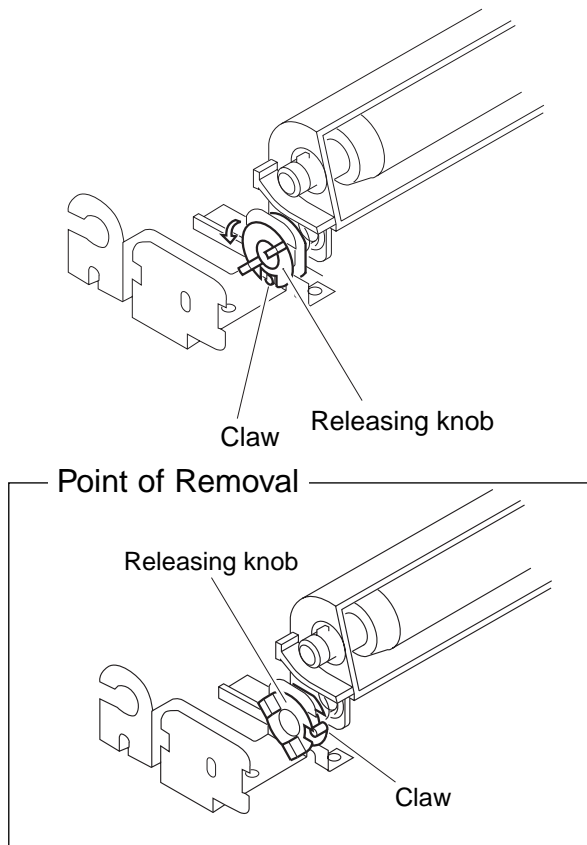
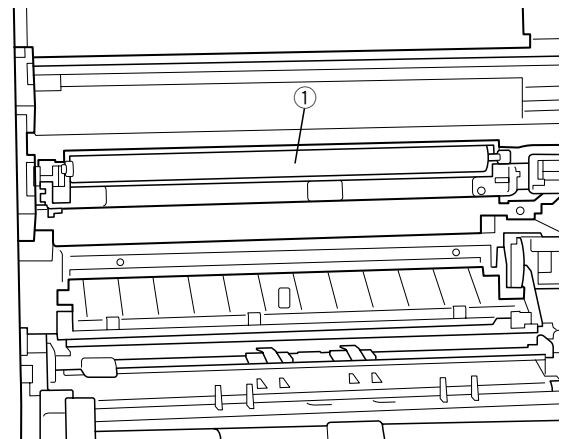

Figure 4-839

- 6) As in step 5), match the releasing knob found on the right end of the ITD cleaning holder assembly.
- 7) Pull out both ends of the ITD cleaning holder assembly to take out the ITD cleaning holder assembly horizontally.



① ITD cleaning holder assembly

Figure 4-840

8. Removing the ITD Cleaning Roller

- 1) Take out the ITD cleaning roller.
- 2) Pull out the roller roll to the front, and slide it to the right; then, detach the ITD cleaning roller.



① Roller roll
② ITD cleaning roller solenoid

Figure 4-841

Note: _____

Take care not to touch the surface of the roller.

9. Removing the Separation Static Eliminator

- 1) Open the front cover.
- 2) While pressing the releasing button, shift the releasing lever 2 in the direction of the arrow.

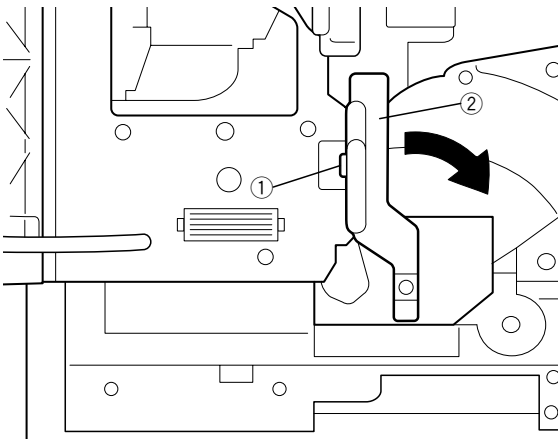

- ① Releasing button
- ② Releasing lever 2

Figure 4-842

- 3) Holding the releasing lever, pull out the separation static eliminator horizontally.

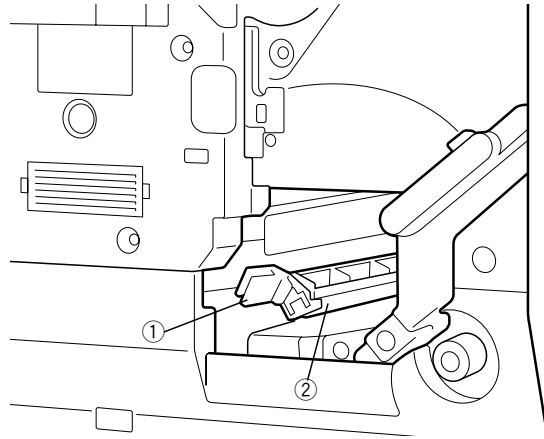

- ① Releasing lever
- ② Separation static eliminator

Figure 4-843

Caution: _____

When replacing the separation static eliminator, take care not to touch the charging wire.

C. PCBs

1. Removing the Main Relay PCB

- 1) Perform the step on p. 4-56 to remove the high-voltage PCB 2.
- 2) Perform step 6) on p. 4-43 to remove the rear cover stay.
- 3) Remove the two screws, and disconnect the eight connectors; then, detach the main relay PCB.

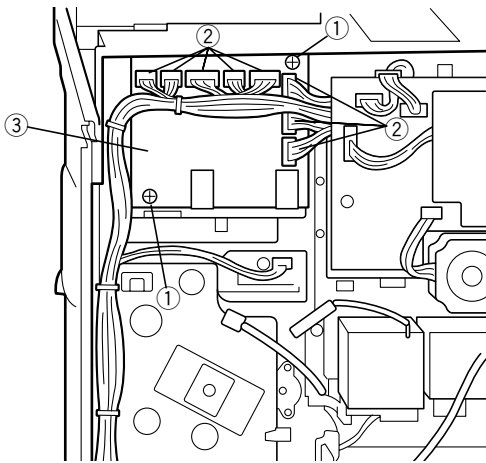

- ① Screw
- ② Connectors
- ③ Main relay PCB

Figure 4-844

2. Removing the Sub Relay PCB

- 1) Perform the steps on p. 3-20 to detach the inside cover 1.
- 2) Remove the four screws, and disconnect the five connectors; then, detach the sub relay PCB.

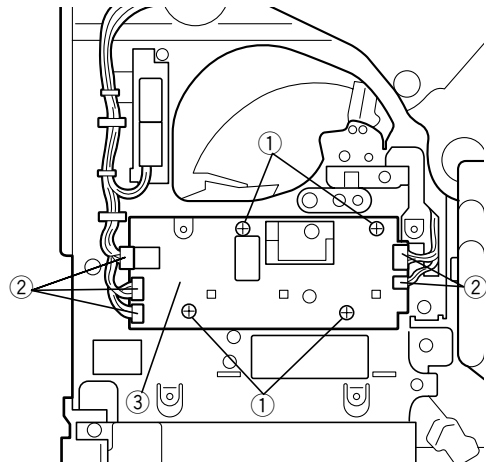

- ① Screws
- ② Connectors
- ③ Sub relay PCB

Figure 4-845

3. Removing the Video Interface PCB

- 1) Perform the steps on p. 3-16 to remove the rear cover.
- 2) Remove the four screws, and disconnect the two connectors on the DC controller PCB; then, detach the video interface PCB.

- 3) Remove the two screws and the two hex nuts; then, detach the video interface PCB from the metal plate.

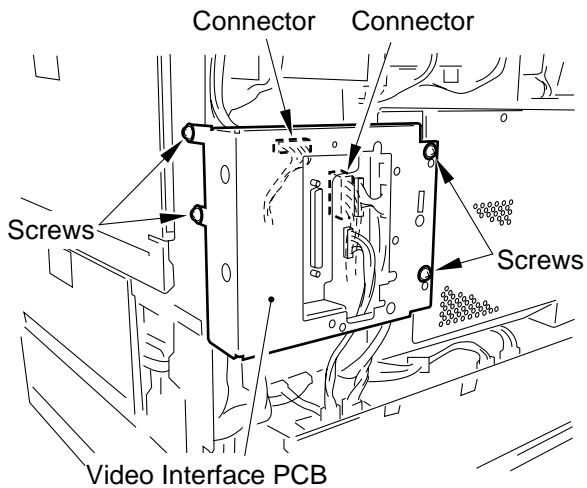

Figure 4-846

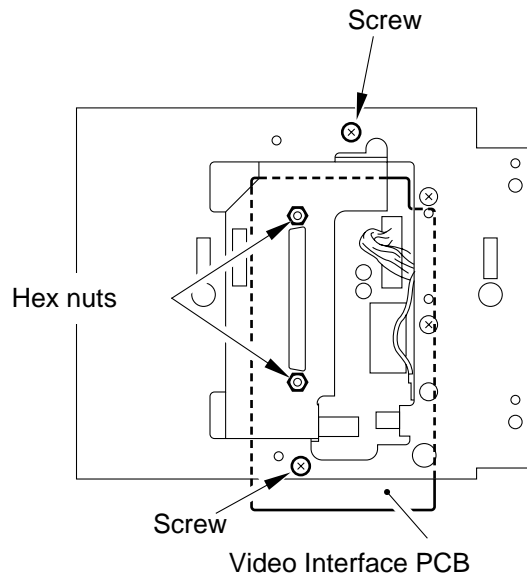

Figure 4-847

4. Removing the DC Controller PCB

- 1) Perform the steps on p. 3-16 to remove the rear cover.
- 2) Perform the steps on p. 4-54 to remove the video interface PCB.
- 3) Remove the four screws, disconnect the 24 connectors, and free the claw; then, slowly detach the DC controller PCB horizontally.

Caution:

1. Connectors to the high-voltage PCB 2 are found on the back of the DC controller PCB, possibly subjected to force during replacement. Be sure to keep the DC controller PCB horizontally and take care during replacement work.
2. The red connector (J204) on the DC controller PCB must be used for the cable from the video interface PCB unit.

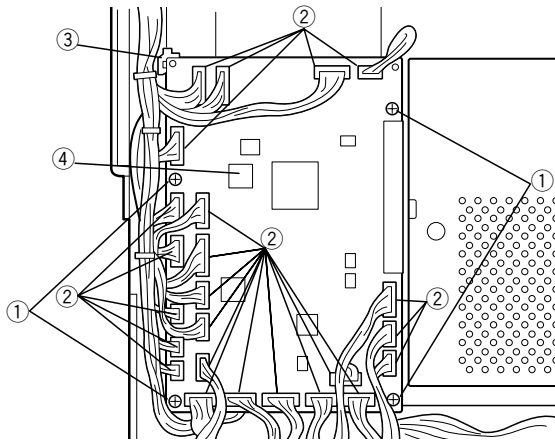

- | | |
|----------|---------------------|
| ① Screws | ② Connectors |
| ③ Claw | ④ DC controller PCB |

Figure 4-848

5. Removing the High-Voltage PCB 1

- 1) Perform steps 1) and 2) through 7) on p. 4-43 to remove the upper cover, rear cover, and rear cover stay.
- 2) Remove the three screws, and disconnect the three connectors; then, slide high-voltage PCB 1 upward to remove.

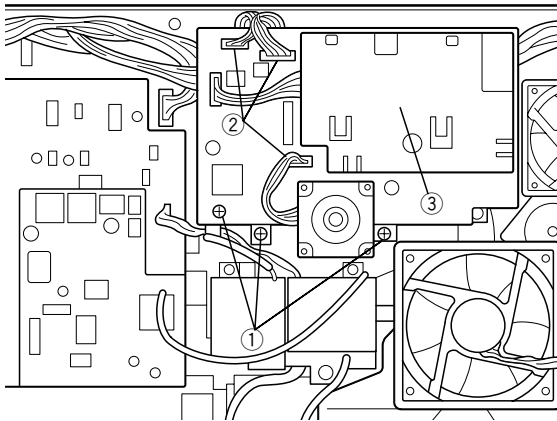

- ① Screws
- ② Connector
- ③ High-voltage PCB 1

Figure 4-849

Note: Do not touch the VR on the high-voltage PCB 1. It is for the factory only.

6. Removing the High-Voltage PCB 2

- 1) Perform the steps on p. 4-55 to remove the DC controller PCB.
- 2) Remove the two screws, disconnect the four connectors, and remove the two cable clamps; then, detach the high-voltage PCB 2.

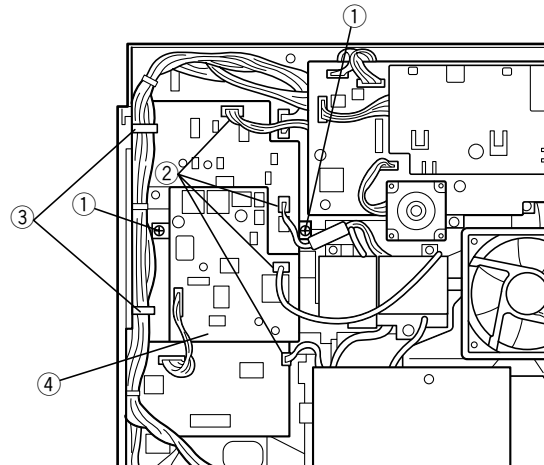

- ① Screws
- ② Connectors
- ③ Cable clamps
- ④ High-voltage PCB 2

Figure 4-850

Note: Do not touch the VR on the high-voltage PCB 2. It is for the factory only.

7. Removing the Separation Static Eliminating Bias PCB

- 1) Perform steps 2) through 5) on p. 4-43 to remove the rear cover and the shielding box.
- 2) Remove the two screws, and disconnect the three connectors; detach the separation static cleaning bias PCB.

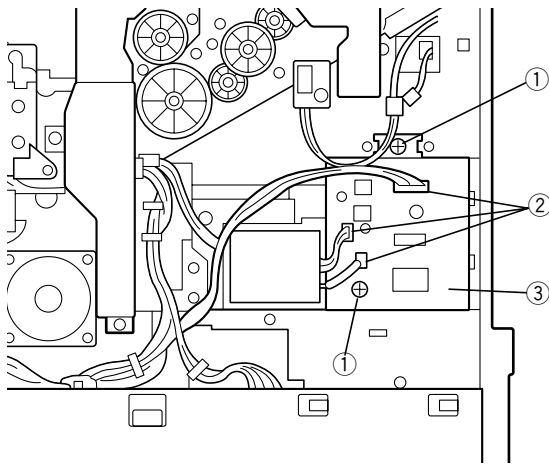

- ① Screw
- ② Connectors
- ③ Separation static eliminating bias PCB

Figure 4-851

8. Removing the Developing Rotary Motor PCB

- 1) Perform the steps on p. 3-16 to remove the rear cover.
- 2) Remove the screw, remove the three claws, and disconnect the six connectors; then, detach the developing rotary motor PCB.

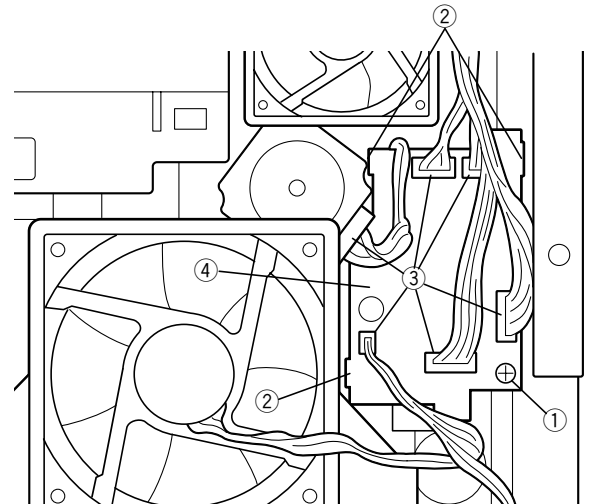

- ① Screw
- ② Claws
- ③ Connectors
- ④ Developing rotary motor PCB

Figure 4-852

9. Removing the Density Detection PCB

- 1) Open the right cover.
- 2) Remove the six claws, and detach the holder cover.

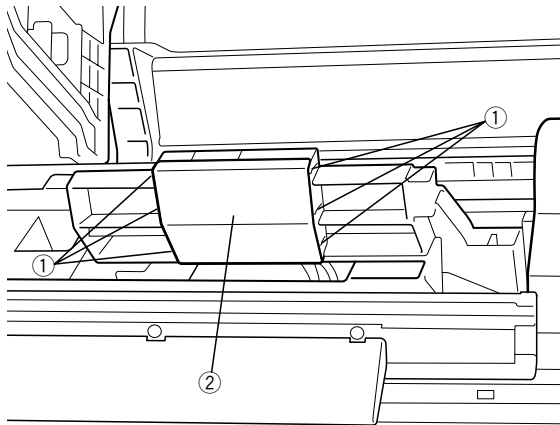

- ① Claw ② Holder cover

Figure 4-853

- 3) Remove the two screws.

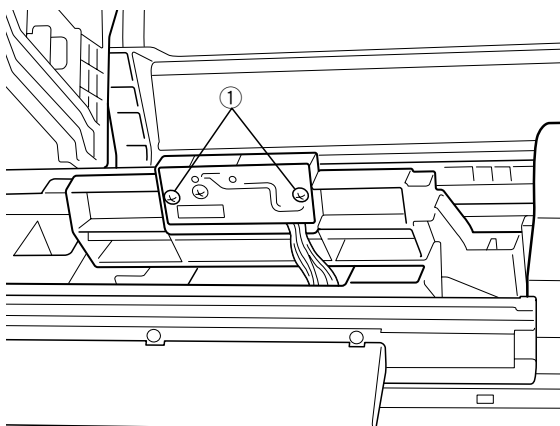

- ① Screws

Figure 4-854

- 4) Disconnect the connector, and detach the density detection PCB.

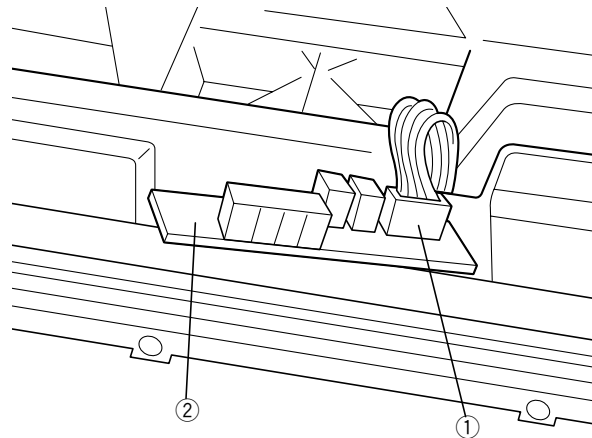

- ① Connector
② Density detection PCB

Figure 4-855

Note:

When replacing the density detection PCB, take care not to touch the sensor assembly.

10. Removing the Sub Transformer 1

- 1) Perform steps 2) through 5) on p. 4-43 to remove the rear cover and the shielding box.
- 2) Perform step 3) on p. 4-55 to remove the DC controller PCB.
- 3) Remove the two screws, and disconnect the two connectors; then, detach the sub transformer 1.

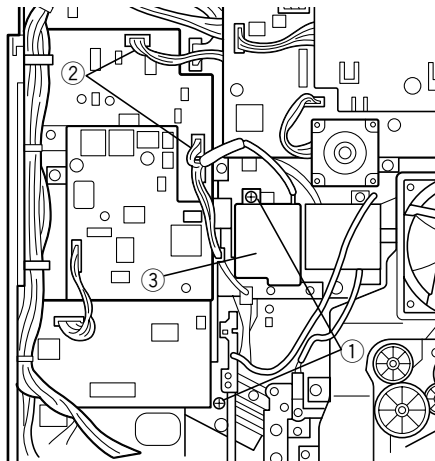

- ① Screws
- ② Connector
- ③ Sub transformer 1

Figure 4-856

11. Removing the Sub Transformer 2

- 2) Perform steps 2) through 5) on p. 4-43 to remove the rear cover and the shielding box.
- 2) Remove the screw, and disconnect the three connectors; then, detach the sub transformer 2.

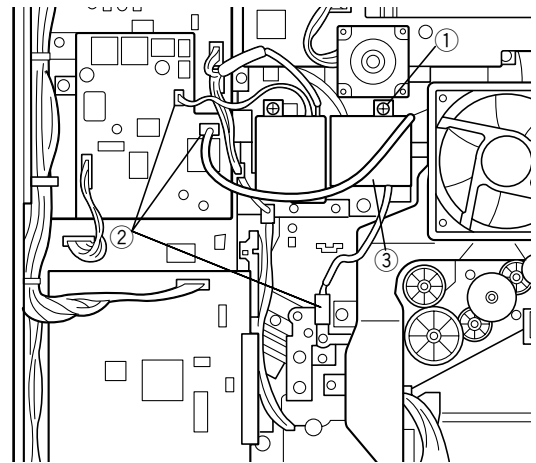

- ① Screws
- ② Connectors
- ③ Sub transformer 2

Figure 4-857

12. Removing the Sub Transformer 3

- 1) Perform the steps on p. 4-57 to remove the separation static eliminating bias PCB.
- 2) Remove the two screws, and detach the duct cover.

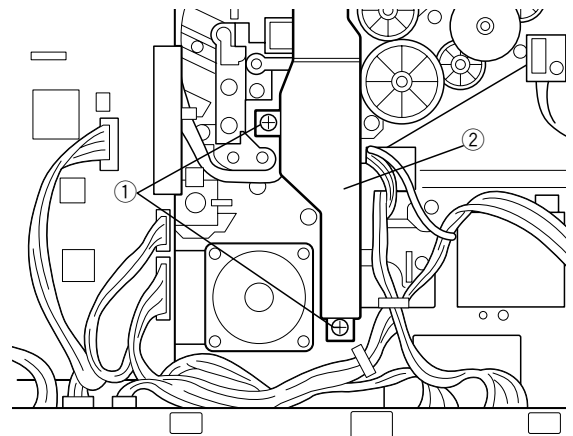

- ① Screws
- ② Duct cover

Figure 4-858

- 3) Remove the screw, and remove the sub transformer 3.

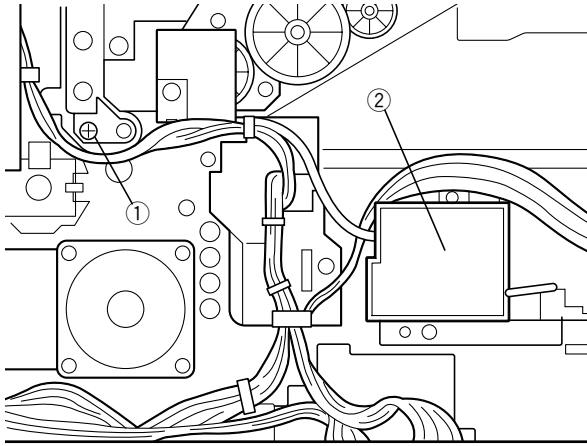

- ① Screw ② Sub transformer 3

Figure 4-859

13. Removing the Color Toner Cartridge Sensor

- 1) Perform the steps on p. 3-20 to remove the inside cover 1.
- 2) Remove the screw, and disconnect the connector; then, remove the color toner cartridge sensor.

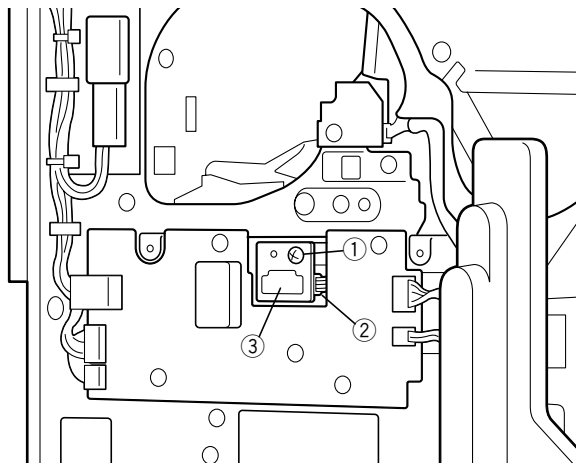

- ① Screw ② Connector
③ Color toner cartridge sensor

Figure 4-860

14. Removing the Color Toner Cartridge Level Sensor

- 1) Perform steps 2) through 6) on p. 4-43 to remove the rear cover, shielding box, and heat discharge fan 1.
- 2) Remove the screw, and disconnect the connector; then, detach the color toner cartridge level sensor.

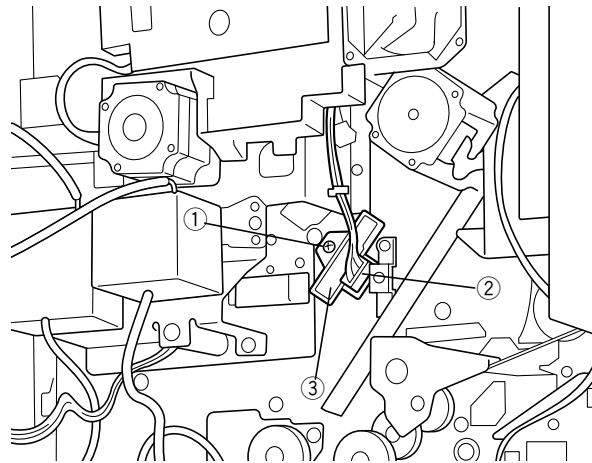

- ① Screw ② Connector
③ Color toner cartridge level sensor

Figure 4-861

Note:

When replacing the color toner cartridge level sensor, take care not to touch the light-receiving/-emitting section.

15. Removing the Color Toner Cartridge Releasing Lever Sensor

- 1) Perform the steps on p. 3-20 to remove the inside cover 1.
- 2) Remove the screw, and disconnect the connector; then, detach the color toner cartridge releasing lever sensor.

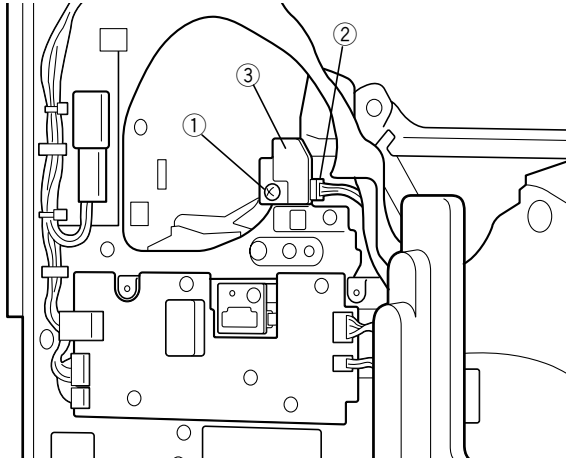

- ① Screw
- ② Connector
- ③ Color toner cartridge releasing lever sensor

Figure 4-862

16. Removing the Temperature/Humidity Sensor

- 1) Remove the cassette 1/2.
- 2) Remove the three claws, and disconnect the connector; then, detach the temperature/humidity sensor.

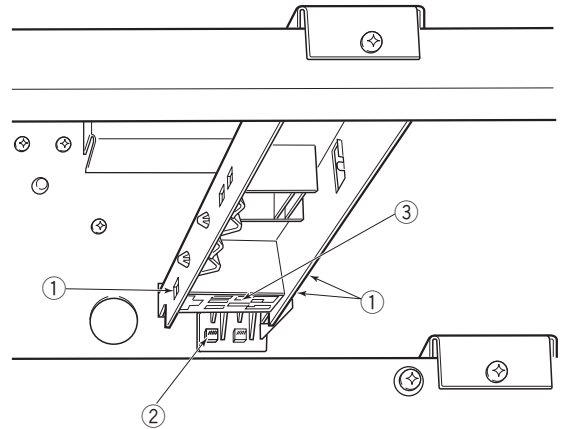

- ① Claws
- ② Connector
- ③ Temperature/humidity sensor

Figure 4-863

CHAPTER 5

PICK-UP/FEEDING SYSTEM

This chapter provides descriptions on the machine's operations between pickup and delivery, functions of each operation, relationships between electrical and mechanical systems, and timing at which each associated part is turned on.

I.	OUTLINE.....	5-1			
	A. Outline.....	5-1			
II.	PICK-UP ASSEMBLY.....	5-3			
	A. Pick-Up from the Cassette.....	5-3			
	B. Pick-Up from the Multifeeder Tray.....	5-16			
	C. Controlling the pick-up motor.....	5-19			
III.	FEEDING/DELIVERY ASSEMBLY.....	5-21			
	A. Outline.....	5-21			
IV.	DUPLEXING UNIT.....	5-22			
	A. Outline.....	5-22			
	B. Reversing Operation.....	5-25			
	C. Horizontal Registration Adjustment.....	5-26			
	D. Re-Pickup.....	5-28			
V.	DETECTING JAMS.....	5-29			
	A. Detecting Jams in the Printer Unit ...	5-29			
	B. Detecting Jams in the Duplexing Unit.....	5-32			
VI.	DISASSEMBLY/ASSEMBLY.....	5-34			
	A. Pick-Up Assembly.....	5-35			
	B. Delivery Assembly.....	5-39			
	C. Feeding Assembly.....	5-40			
	D. Registration Roller Assembly.....	5-40			
	E. Multifeeder Pick-Up Assembly.....	5-42			
	F. Multifeeder Tray Pick-Up Roller.....	5-44			
	G. Multifeeder Tray Separation Pad.....	5-45			
	H. Cassette Pick-UP, Feeding, and Separation Rollers.....	5-45			
	I. PCBs.....	5-46			

I. OUTLINE

A. Outline

When the PRNT* signal arrives from the printer board*¹ and the scanner motor becomes ready, the DC controller PCB starts printing operation.

In the case of pick-up from the cassette, paper is fed into the printer unit by the pick-up roller and is moved by the feeding roller; in the case of pick-up from the multifeder, on the other hand, the multifeder pick-up roller feeds paper into the printer unit.

The orientation of the paper is corrected by the registration roller so that it will not move askew; the paper is then stopped and kept in wait. Then, the paper is started once again so that its leading edge and the leading edge of the image on the intermediate transfer drum will match; the paper is further moved through the transfer, separation, and fixing/delivery assemblies all the way to the face-down tray or the face-up tray.

*¹ Reader controller PCB (when making prints with the reader unit installed).

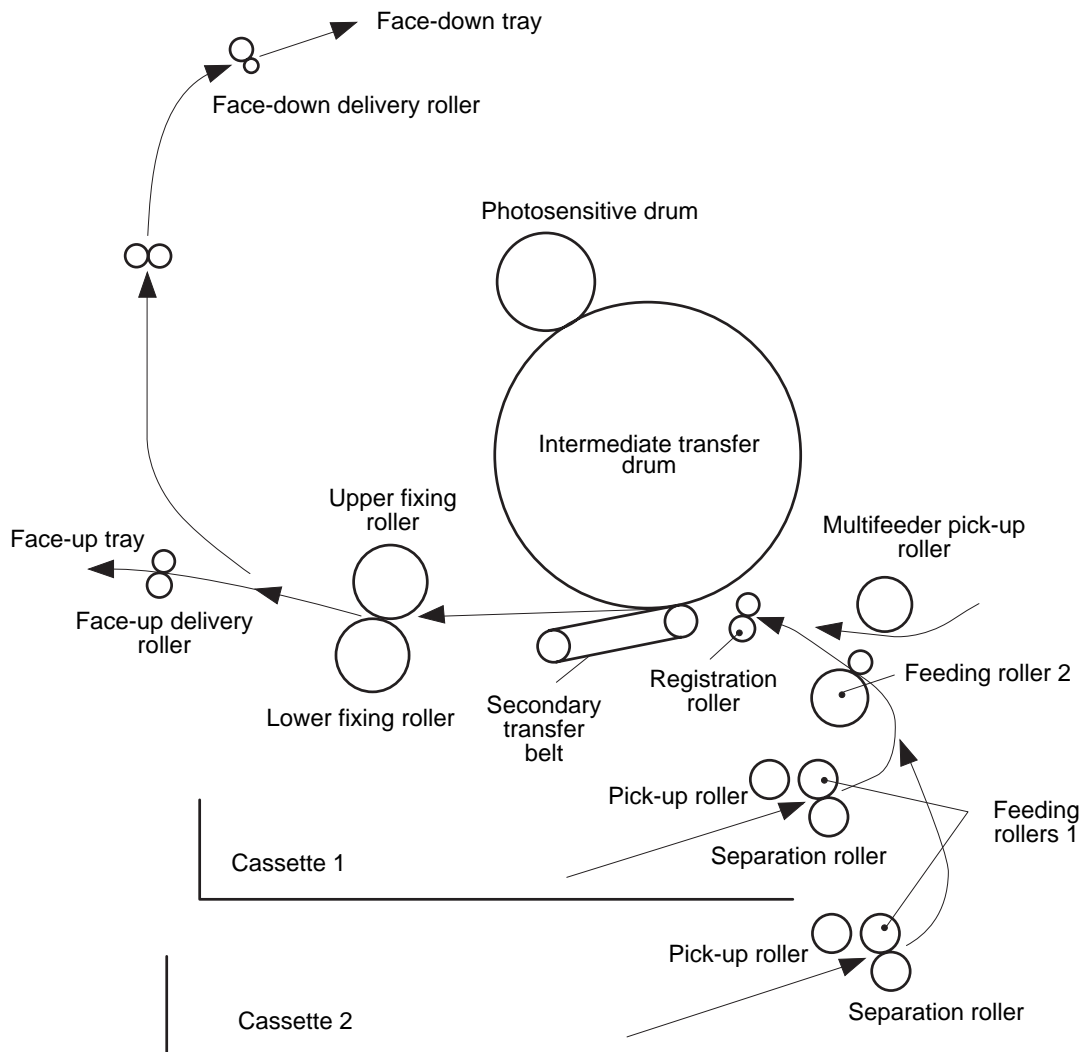

Figure 5-101

The printer unit switches over three feeding speeds according to the paper type mode signal from the printer board*1. Table 5-101 shows the speed used for each paper type.

The feeding speed is switched when paper arrives at the registration paper sensor (PS1).

Mode	Normal	Thick paper	Transparency
Feeding speed	Normal	1/3 of normal	1/4 of normal

Table 5-101

The printer unit enters transparency mode when the user selects transparencies on the control panel. To enable the printer unit to identify a transparency, transparency sensors 1 and 2 (PS1801, PS1802; Figure 5-213) are mounted in front of the pick-up roller. The DC controller PCB monitors the states of the sensors to identify a transparency (Note).

A Canon-recommended transparency (OHT TH-1) or a transparency for a color copier has a marking on its leading edge. The marking blocks either of the two sensors (PS1801, PS1802), causing the DC controller PCB to assume that the transparency is of a type that cannot be used for the printer unit; it then communicates the fact to the printer board¹ and, at the same time, stops the printer unit (Note 2).

*1 Reader controller PCB (when making prints with the reader unit installed).

Note:

1. Paper is stopped once at the registration roller before re-pickup, and the DC controller PCB checks the two sensors (PS1801, PS1802) during this period.

The sensors are of a feedback type, consisting of a light-emitting section and a light-receiving section. If a transparency exists between the sections, the light from the light-emitting section passes through it to reach the light-receiving section, enabling the DC controller PCB to identify the medium as a transparency, thereby starting transparency mode.

2. Canon-recommended transparencies (OHT TH-10) are extremely thin, and are impregnated with oil. The printer unit, on the other hand, uses two fixing heaters, and the high caloric value can cause such transparencies to jam inside the fixing assembly.

Likewise, the printer unit rejects transparencies intended for a color copier (identifying them as such in response to the marking on the leading edge by stopping the ongoing operation).

II. PICK-UP ASSEMBLY

A. Pick-Up from the Cassette

1. Pick-Up Operation

The printer unit moves up the paper inside the cassette using a lifter to pick-up position; then, it brings down a rotating pick-up roller to come into contact with the paper for pick-up.

The series of pick-up operations is executed in response to the PRNT* signal, and the main motor is used to bring down the pick-up roller to the stack of paper, while the pick-up motor is used to rotate the pick-up roller.

When the printer board1 sends the PRNT* signal to the printer unit, the main motor (M4) and the pick-up motor (M5) start to rotate. When the cassette pick-up solenoid (SL3) turns on, the drive of the main motor is sent to the cassette pick-up cam through gears, and the rotation of the cam moves the lift arm.

At the same time, the drive of the pick-up motor is sent through the feeding roller gears to reach the cassette pick-up roller. The rotating cassette pick-up roller moves down to the stack of paper, and a single sheet of paper is picked up, at the end of which the pick-up roller moves to its initial position and stops.

When the pick-up motor rotates clockwise, the pick-up roller of the cassette 1, feeding roller 1, and separation roller are driven to pick up paper from the cassette 1. When the motor rotates counterclockwise, on the other hand, the pick-up roller of the cassette 2, feeding roller 1, and separation roller are driven to pick up paper from the cassette 2.

*1: Reader controller PCB (when making prints with the reader unit installed).

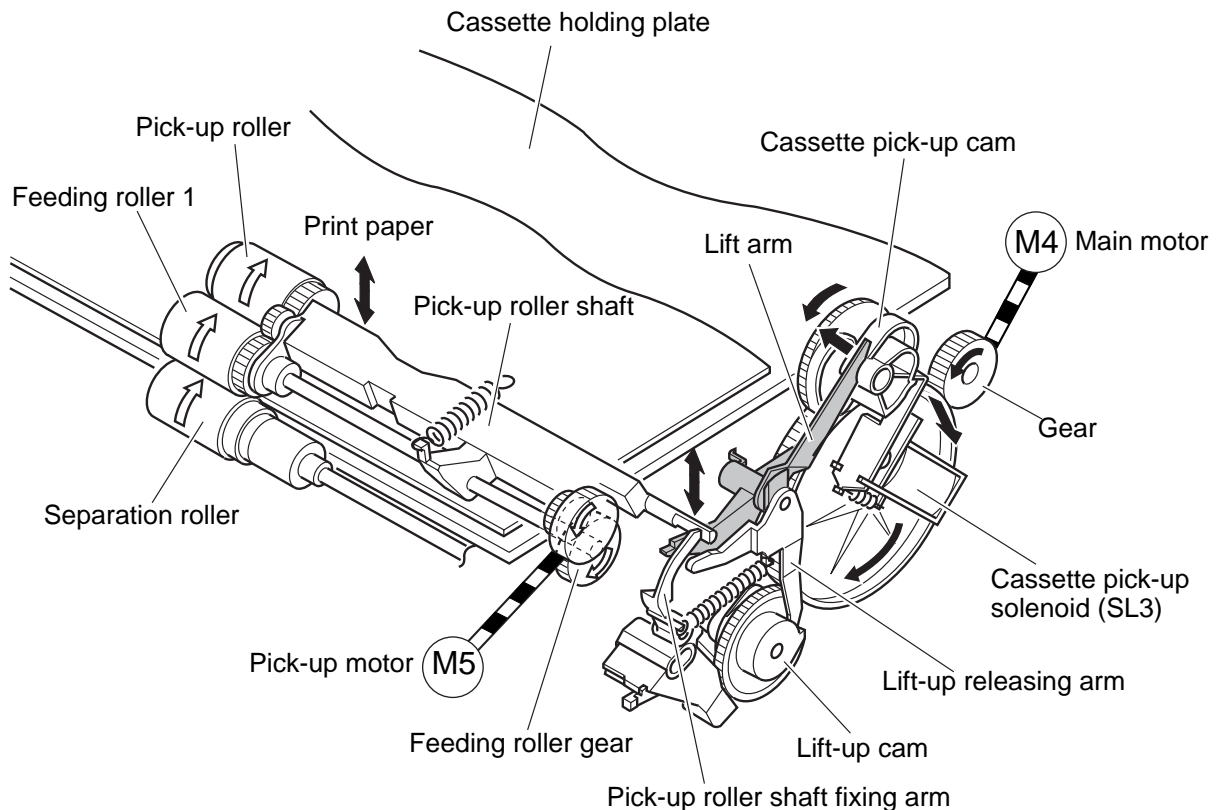

Figure 5-201

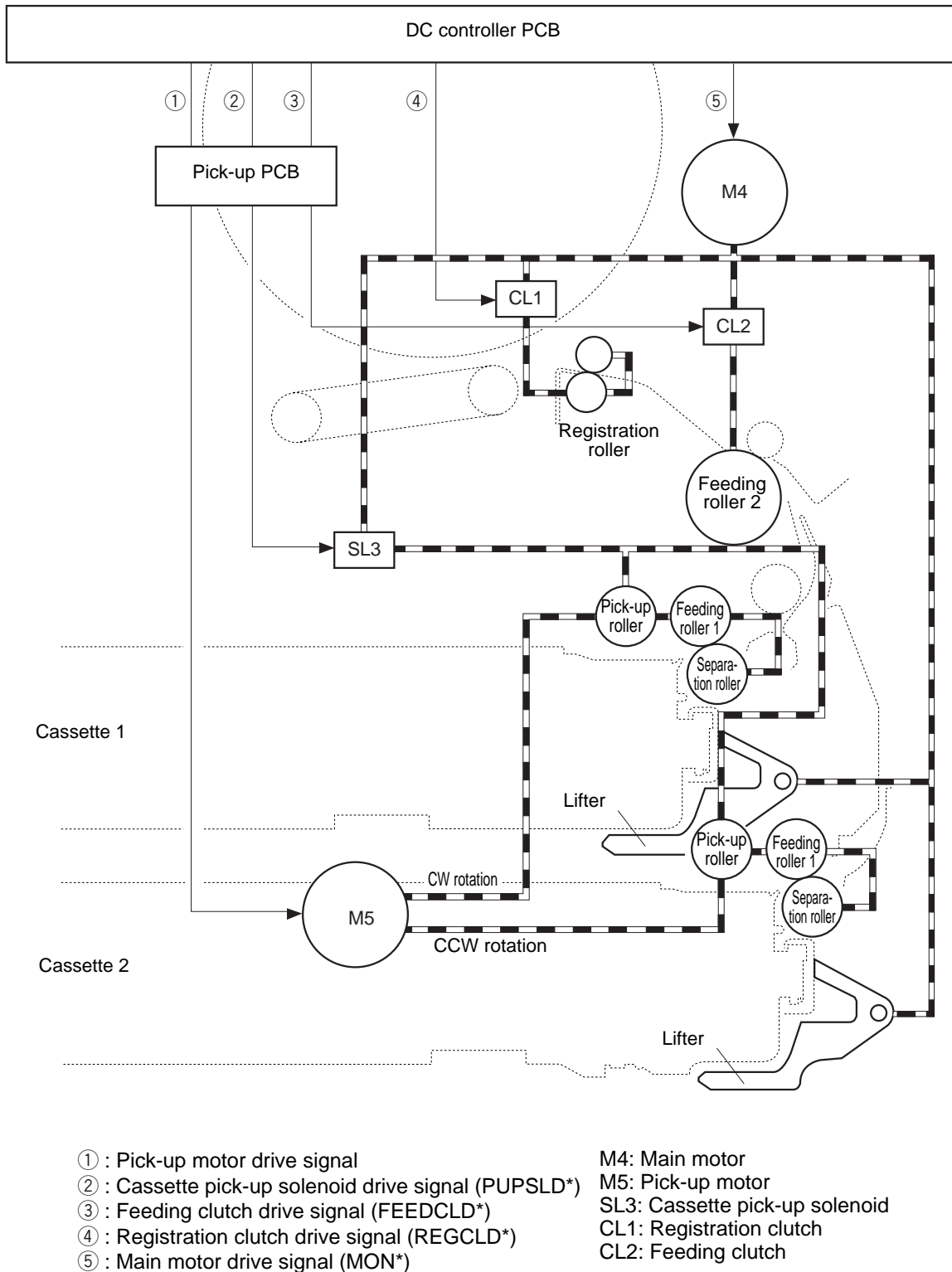
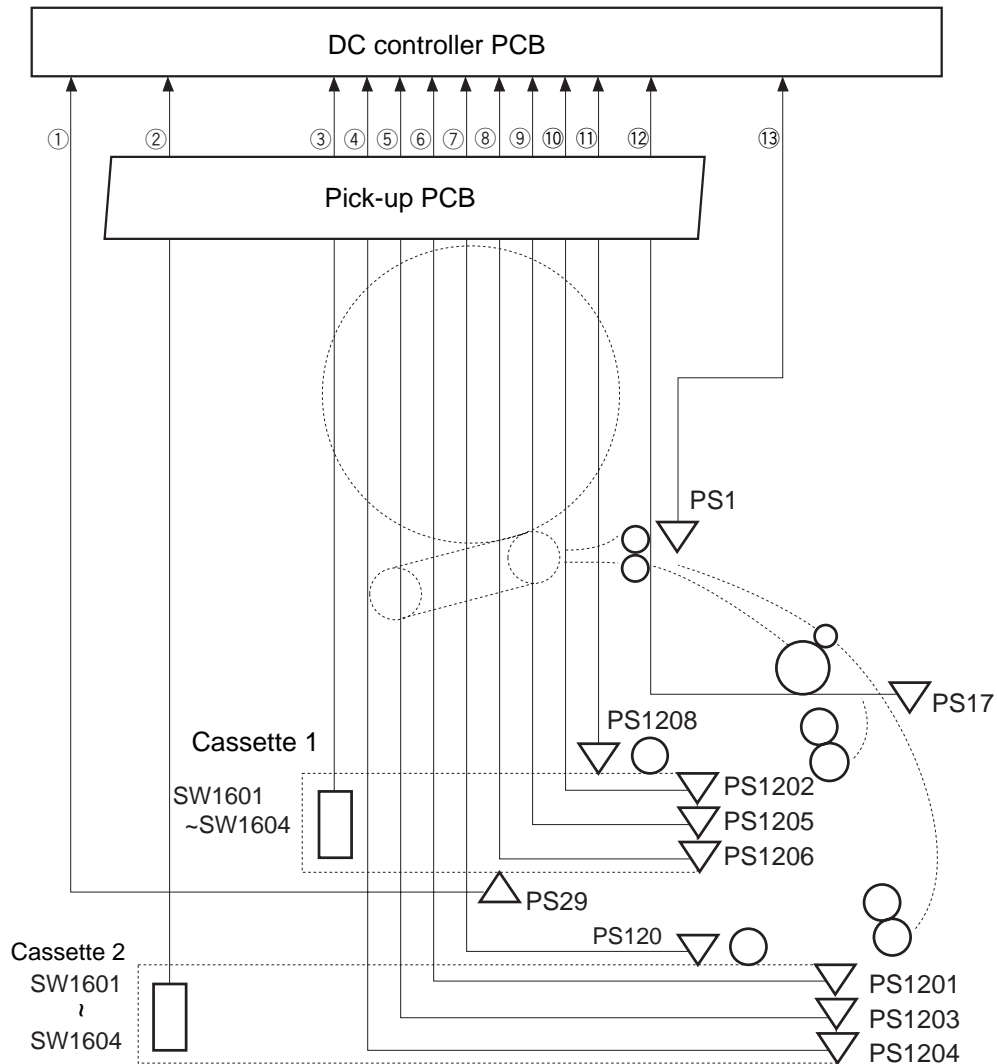

Figure 5-202



- | | |
|---|---|
| <ul style="list-style-type: none"> ① : Cassette 1 last paper detection signal (UCEDFS) ② : Cassette 2 size detection signal ③ : Cassette 1 size detection signal ④ : Cassette 2 paper level detection signal 1 (LPVS1*) ⑤ : Cassette 2 paper level detection signal 2 (LPVS2*) ⑥ : Cassette 2 detection signal (LDECKC*) ⑦ : Cassette 2 paper absent detection signal (LDECKS) ⑧ : Cassette 1 paper level detection signal 1 (UPVS1*) ⑨ : Cassette 1 paper level detection signal 2 (UPVS2*) ⑩ : Cassette 1 detection signal (UDECKC*) ⑪ : Cassette 1 paper absent detecting signal (UDECKS) ⑫ : Pick-up assembly paper detection signal (FEEDS) ⑬ : Registration paper detection signal (REGS*) | <ul style="list-style-type: none"> PS1: Registration paper sensor PS17: Pick-up assembly paper sensor PS29: Cassette 1 last paper sensor PS1201: Cassette 2 sensor PS1202: Cassette 1 sensor PS1203: Cassette 2 paper level sensor 1 PS1204: Cassette 2 paper level sensor 2 PS1205: Cassette 1 paper level sensor 1 PS1206: Cassette 1 paper level sensor 2 PS1207: Cassette 2 paper absent sensor PS1208: Cassette 1 paper absent sensor SW1601: Cassette size switch SW1602: Cassette size switch SW1603: Cassette size switch SW1604: Cassette size switch |
|---|---|

Figure 5-203

2. Detecting the Presence/Absence of a Cassette, Cassette Size, and Paper Level

The presence/absence of the cassette 1 or 2 is checked by the cassette 1 sensor (PS1202) or the cassette 2 sensor (PS1201), and the presence/absence of paper is checked by the cassette 1 paper absent sensor (PS1208) or the cassette 2 paper absent sensor (PS1207).

The size of the paper inside the cassette 2, further, is identified by the four sensors each mounted to the cassette 1 and the cassette 2; i.e., cassette 1 or cassette 2 size detecting switches (SW1601 through SW1604). Table 5-201 shows combinations of the states of the cassette size detecting switches.

Paper size	Cassette size detecting switch			
	SW1601	SW1602	SW1603	SW1604
11 × 17	OFF	OFF	OFF	OFF
A3	OFF	ON	OFF	OFF
B4	ON	OFF	OFF	OFF
LGL	ON	ON	OFF	OFF
LTRR	OFF	OFF	OFF	ON
A4R	OFF	OFF	ON	OFF
A4	ON	OFF	OFF	ON
B5R	OFF	ON	OFF	ON
A5R	OFF	OFF	ON	ON

Table 5-201

The level of paper inside the cassette is checked in relation to the position of the lifter used to move up the stack of paper. The lifter is equipped with a light-blocking plate, and the position of the lifter is checked when the light-blocking plate blocks two sensors, thereby enabling the identification of the level of paper.

In the case of the cassette 1, the outputs of the cassette 1 paper levels sensor 1 (PS1205) and the cassette 1 paper level sensor 2 (PS1206) are used; in the case of the cassette 2, on the other hand, the outputs of the cassette 2 paper level sensor 1 (PS1203) and the cassette 2 paper level sensor 2 (PS1204) are used. Figure 5-204 shows the combinations of the states of PS1205 and PS1206 (or, of PS1203 and PS1204).

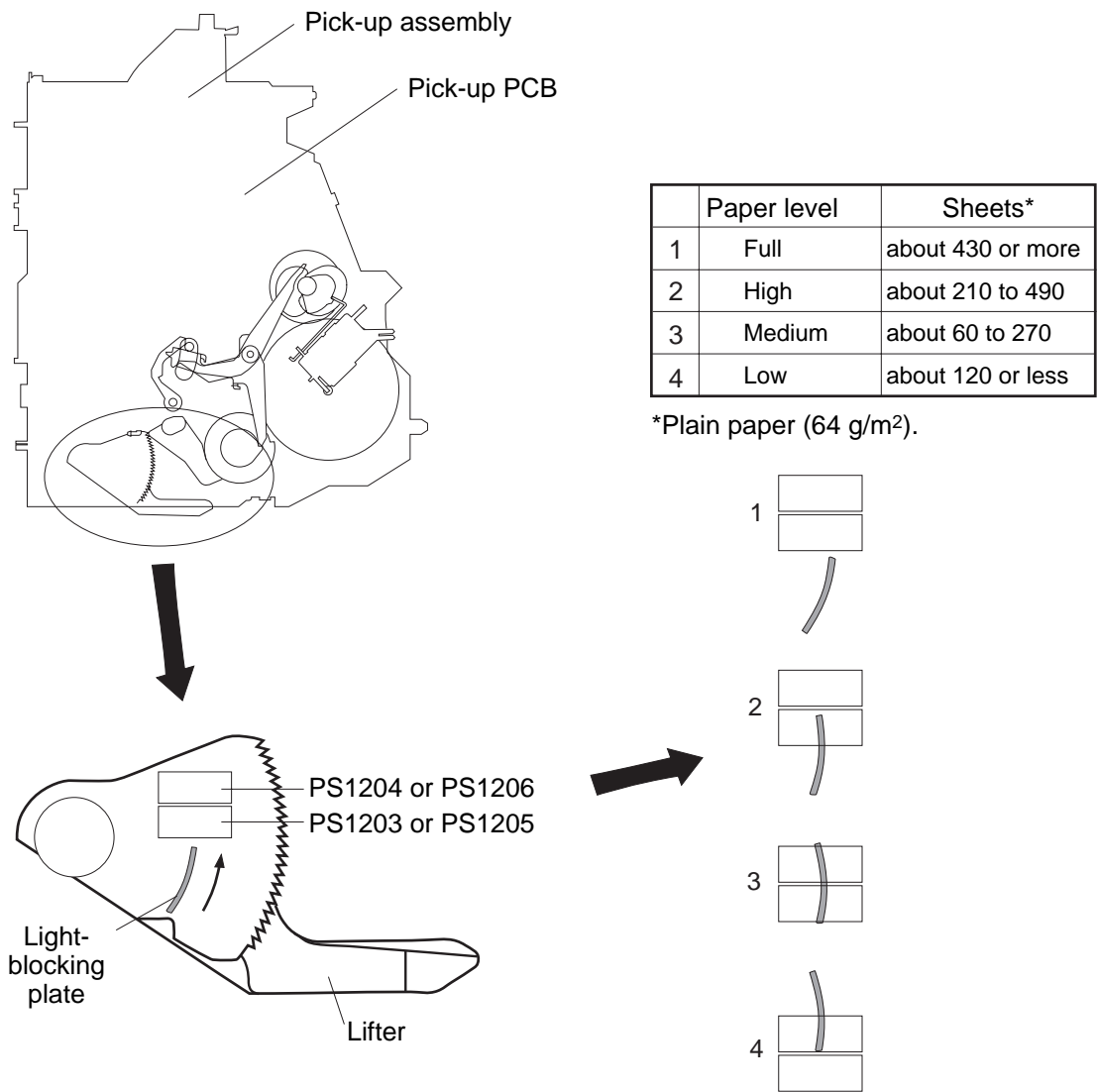

Figure 5-204

3. Lift-Up Operation

The term "lift-up operation" is used to refer to the operation executed when the cassette is slid in or when the pick-up roller shaft falls a specific distance under a lowering stack of paper. The operation is driven by the main motor, and is executed as in the following two cases:

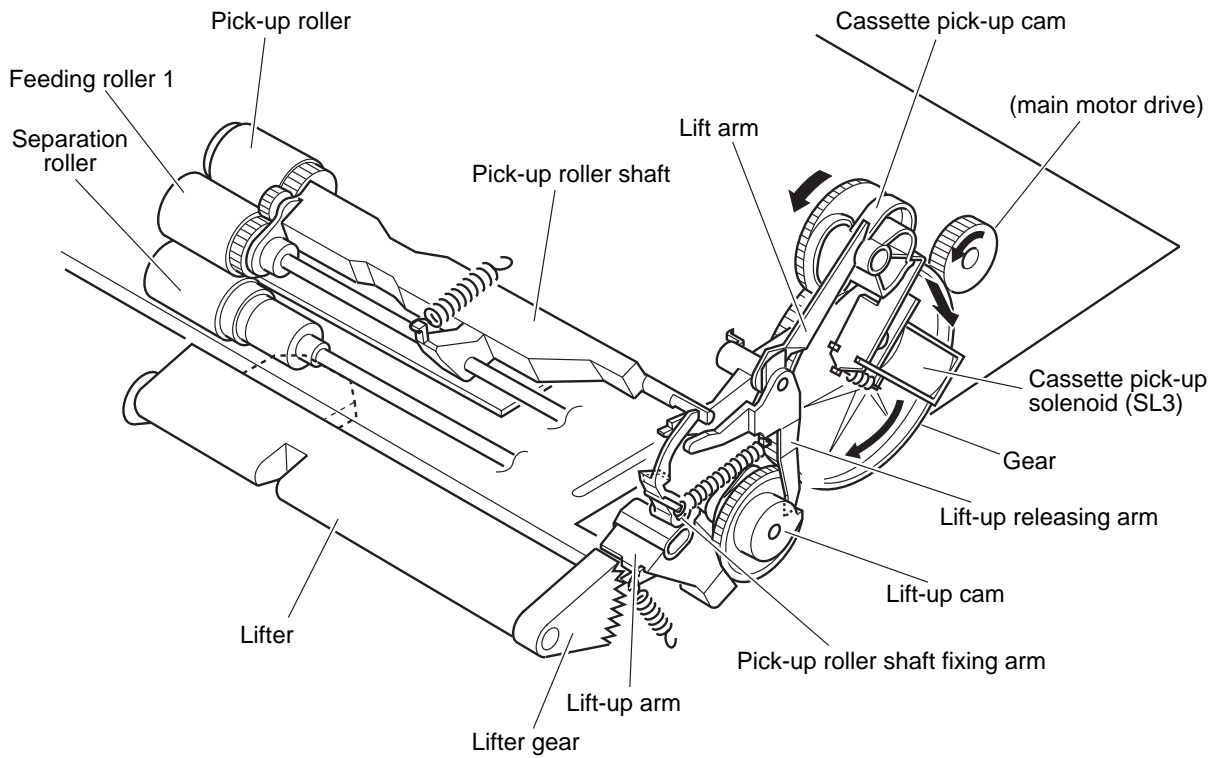

Figure 5-205

a. When the Cassette Is Slid In

- ① When the cassette is slid in, the main motor starts to rotate, and the cassette pick-up solenoid (SL3) turns on. The drive moves through gears and rotates the cassette pick-up cam to operate the lift arm.

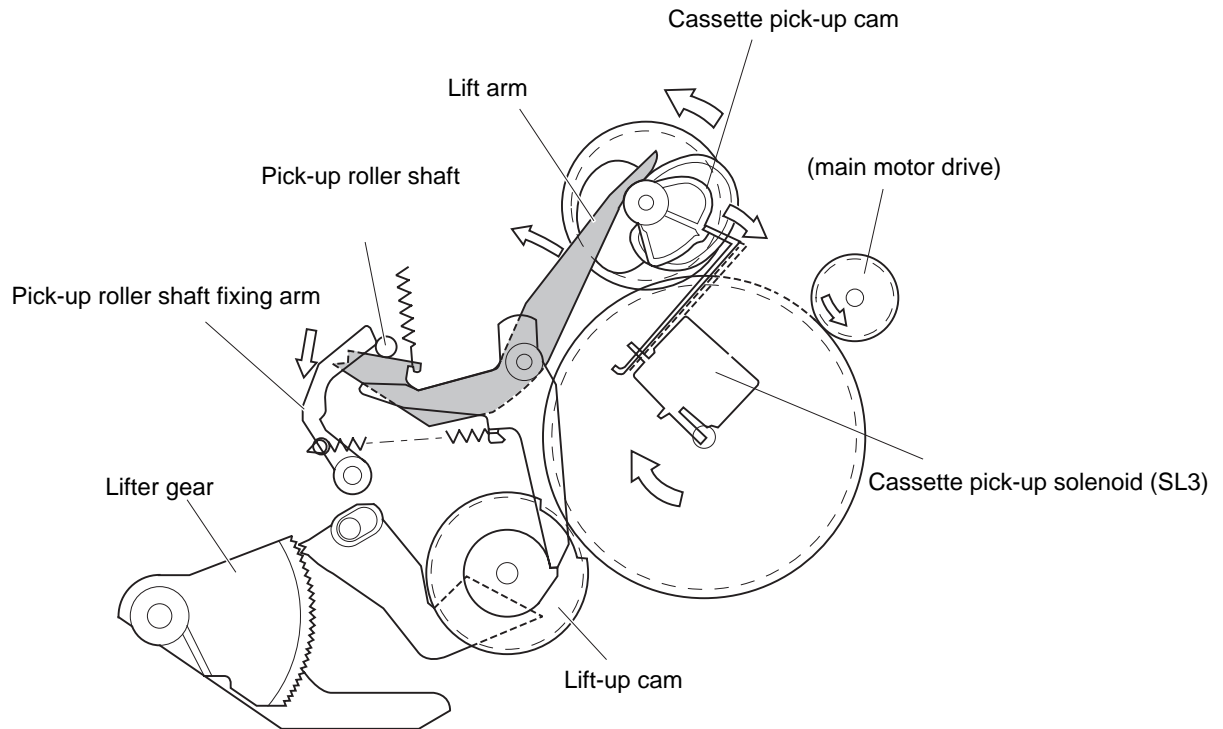

Figure 5-206

- ② When the lift arm lowers, the pick-up roller shaft moves down, pushing the lift-up releasing arm to free the lift-up cam. At the same time, the lift arm is locked to the pick-up roller shaft fixing arm, stopping the pick-up roller shaft at a specific position.

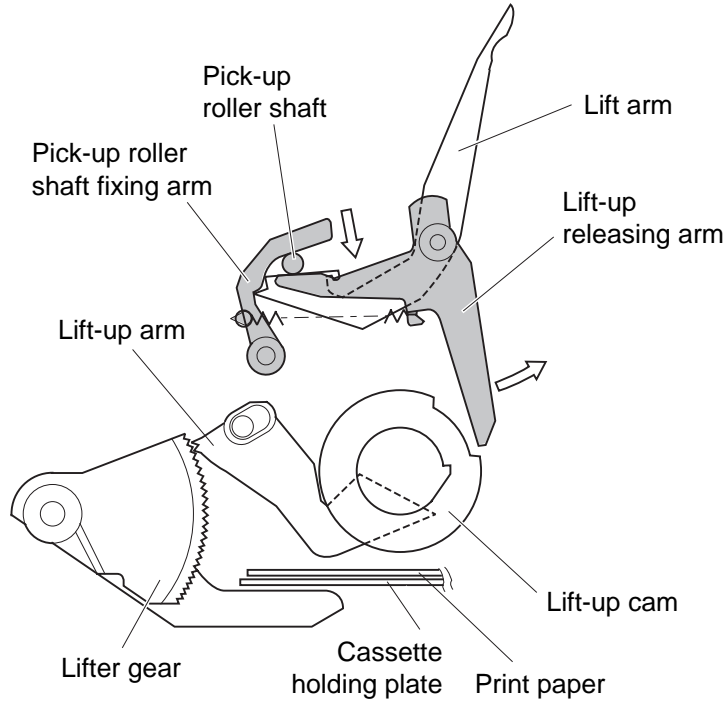

Figure 5-207

- ③ When the lift-up cam is freed, the lift-up cam starts to rotate so that the lift-up arm pushes up the lifter gear by a distance equivalent to a single tooth. These operations are repeated to move up the cassette holding plate.

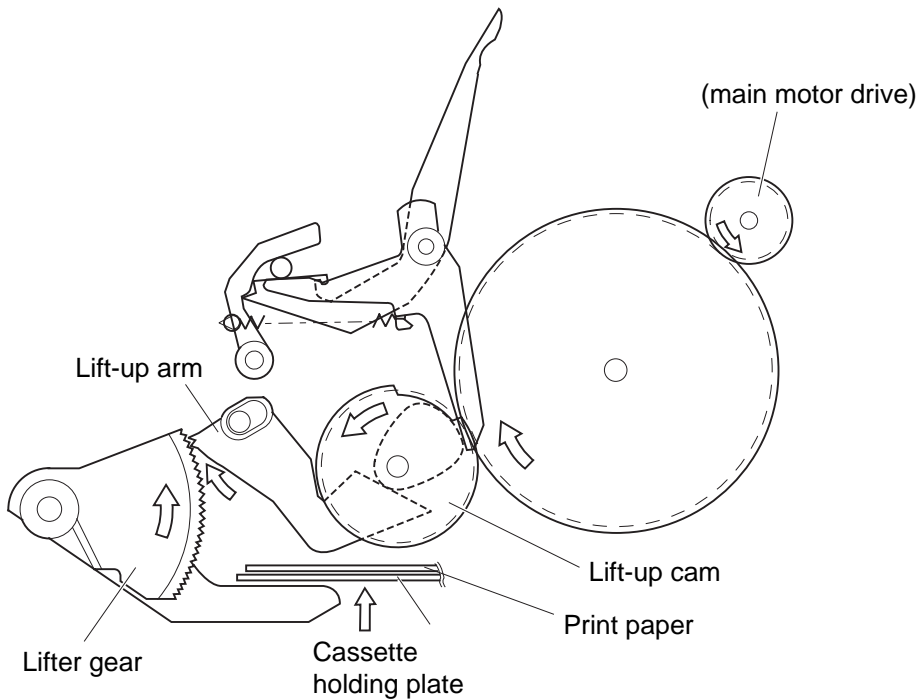

Figure 5-208

- ④ When the paper on the cassette holding plate comes into contact with the pick-up roller, the pick-up roller shaft is pushed up, freeing the fixing arm so that the lift-up releasing arm will move up the pick-up roller shaft to wait position by the force of a spring. At the same time, the pick-up roller shaft fixing arm and the lift-up releasing arm are driven to fix the lift-up cam in place, thereby stopping the lift-up arm and ending the lift-up operation.

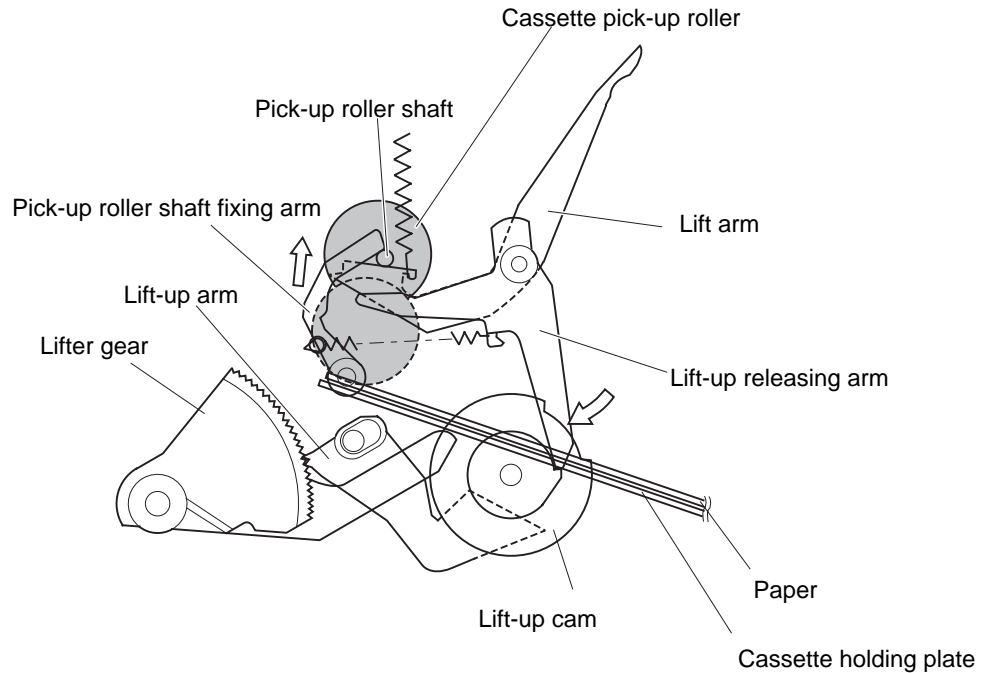
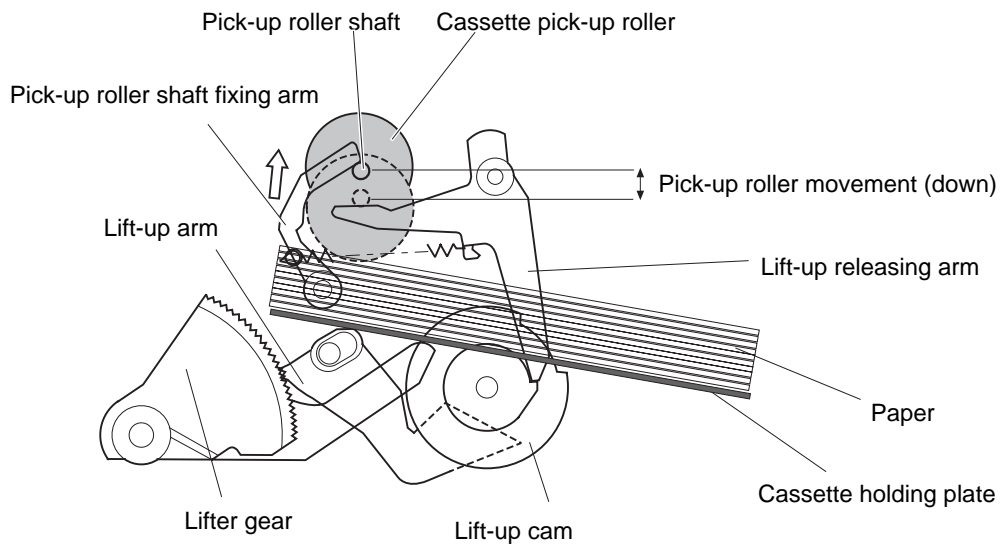

Figure 5-209

b. Decrease in the Stack

- ① When the stack decreases and, as a result, its top surface lowers a specific distance, the pick-up roller moves farther down during pick-up, causing the pick-up roller shaft to push the lift-up releasing arm and the lift-up cam to be freed.

Normal Operation



Decrease in the Stack

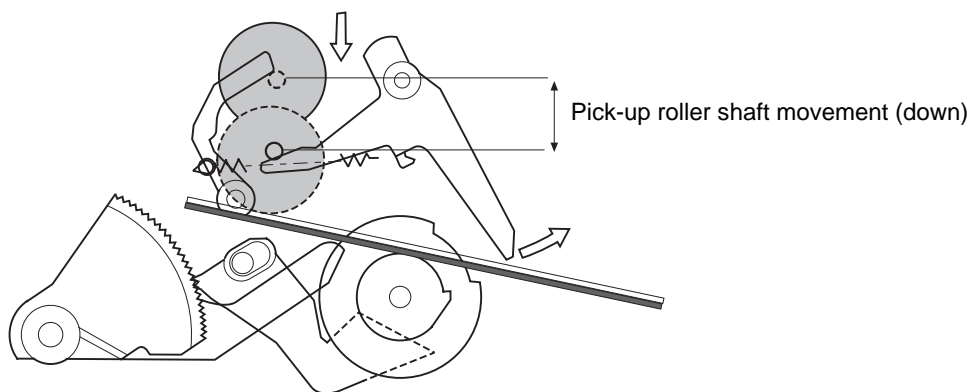

Figure 5-210

- ② When the lift-up cam is freed, the lift-up cam starts to rotate so that the lift-up arm pushes up the lifter gear by a distance equivalent to a single tooth. These operations are repeated to move up the cassette holding plate. (Figure 5-208)
- ③ When the pick-up roller comes into contact with the paper on the cassette holding plate, the pick-up roller shaft is moved up, freeing the fixing arm to cause the lift-up releasing arm to move up the pick-up roller shaft to wait position by the force of a spring. At the same time, the pick-up roller shaft fixing arm and the lift-up releasing arm are driven to keep the lift-up cam in place, causing the lift-up arm to stop and end the lift-up operation. (Figure 5-209)

4. Preventing Double Feeding

The printer unit uses a separation roller to prevent double feeding when pick-up is from the cassette. The separation roller is subjected to a rotating force opposite the rotation of the feeding roller. The separation roller is equipped with a torque limiter, and the rotation of the feeding roller 1 from the moving paper normally forces the separation roller to rotate. In the case of double feeding, however, the weak friction between two sheets of paper makes the rotating force going to the separation roller weak, causing the rotation of the separation roller to move back the extra sheet.

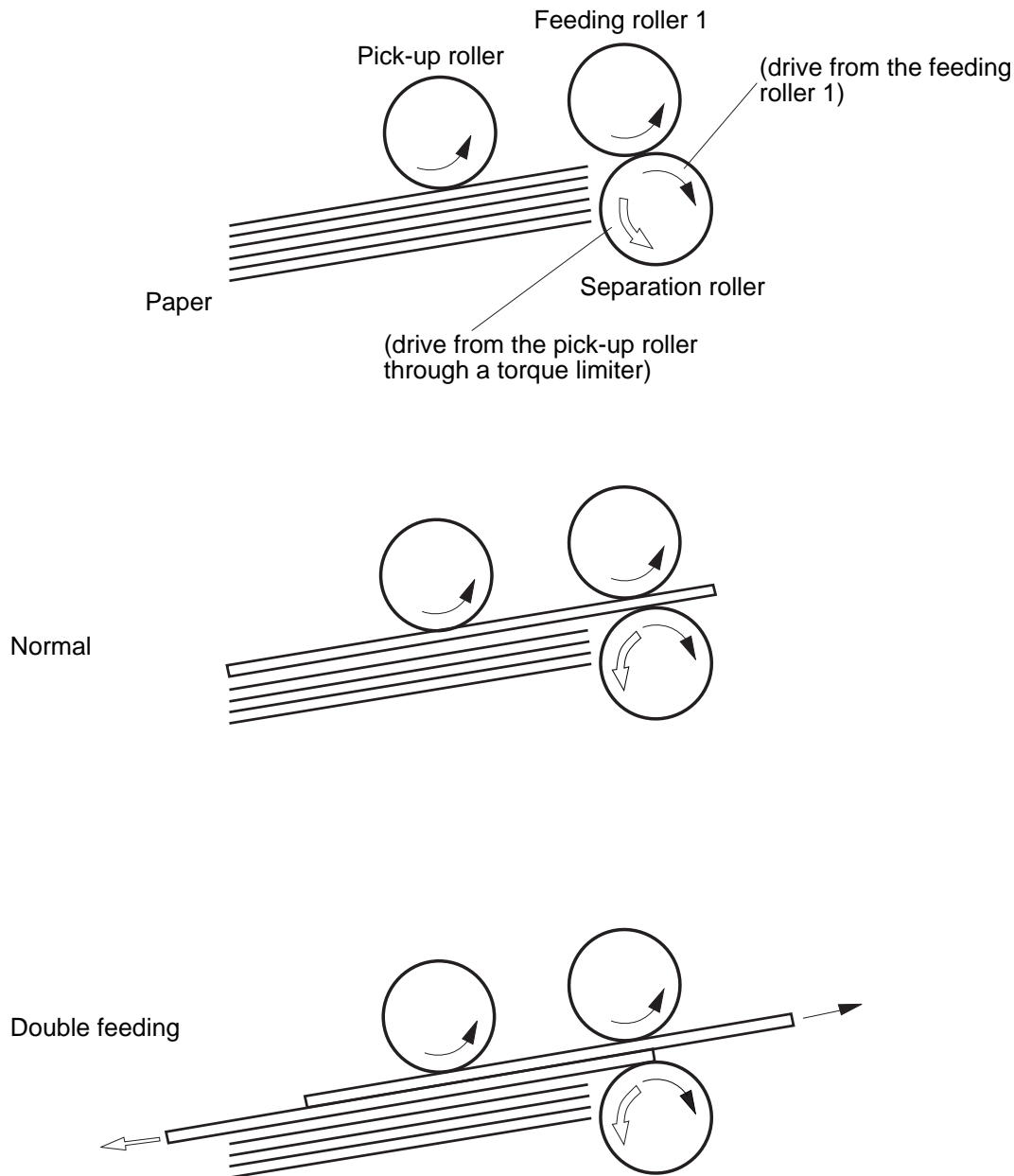

Figure 5-211

5. Cassette 1 Last Sheet Detection

The printer unit is capable of detecting the last sheet from the cassette 1. The feeding distance from the cassette 1 paper absent sensor to the registration roller is short; as such, if the last sheet was picked up during continuous printing, writing would start before the DC controller PCB identifies the absence of paper, requiring the printer unit to detect the absence of paper before writing starts and, ultimately, to prevent soiling between the photosensitive drum and the intermediate transfer drum.

The cassette 1 last sheet sensor (PS29) is a reflecting type sensor, and consists of a light-emitting section and a light-receiving section. In the presence of paper, the light from the light-emitting section will be reflected by the paper to reach the light-receiving section. In the absence of paper (after the last sheet has been picked up), on the other hand, the light from the light-emitting section will pass through the machine's inside, not reaching the light-receiving section.

In response, the DC controller PCB will assume that the last sheet has been picked up, and communicate the fact to the printer board*1 to stop writing of the next image.

*1Reader controller PCB (when making prints with the reader unit installed).

One Sheet Exists in the Cassette 1

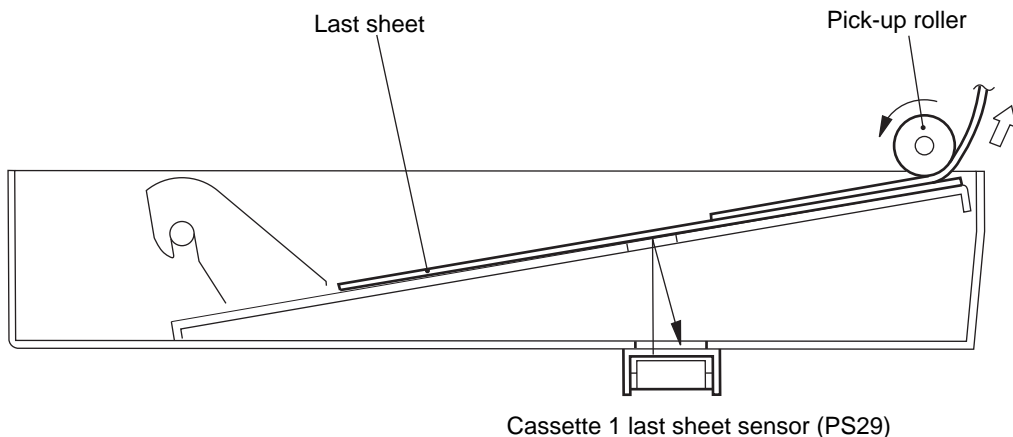

No Sheet Exists in the Cassette 1

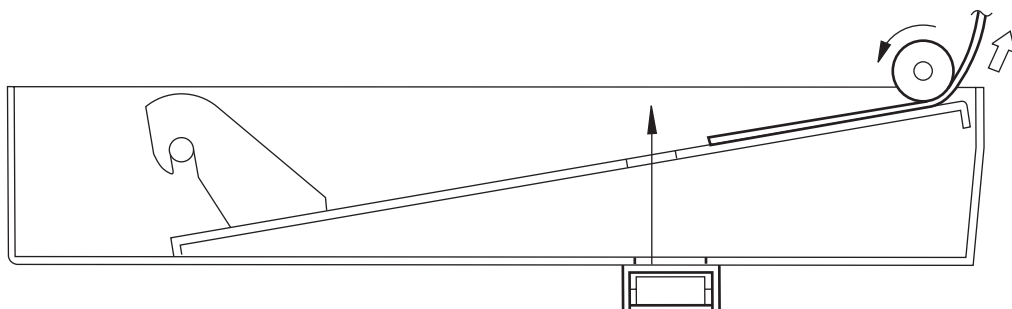

Figure 5-212

B. Pick-Up from the Multifeeder Tray

1. Operation

The presence/absence of paper on the multifeeder tray is checked by the multifeeder tray paper sensor (PS1301).

In response to the PRNT* signal, the DC controller PCB starts the main motor (M4). At the same time, it turns on the holding plate solenoid (SL4) to free the holding plate (so that it may move up), causing the pick-up roller to come into contact with the stack of paper.

The up/down movement of the holding plate is checked by the holding plate sensor (PS1302). If the holding plate is up during the wait period, the holding plate solenoid (SL4) is turned on to bring down the holding plate.

Thereafter, the multifeeder pick-up clutch (CL3) is turned on so that the drive of the main motor (M4) is transmitted to the multifeeder tray pick-up roller.

The stack of paper butted against the multifeeder tray pick-up roller by the holding plate gives up one sheet in response to the rotation of the pick-up roller. After the extra sheet, if any, has been removed by the work of the separation pad, the paper is moved inside the printer unit. The operations that follow are the same as in cassette pick-up; however, the holding plate solenoid (SL4) is additionally turned on immediately after the registration roller starts to rotate to move down the holding plate.

The multifeeder tray paper width sensor (PS1701) is mounted inside the feeder tray, detecting the width of paper in relation to the slide resistor operating in conjunction with the size guide plate.

The DC controller PCB detects the width of paper, if any on the multifeeder tray; if the paper is of a width different from the width specified by the printer board*1, it will identify a paper size mismatch, and communicate the fact to the printer board1 and, at the same time, issues a message on the printer control panel to warn the user.

*1 Reader control PCB (when making prints with the reader unit installed).

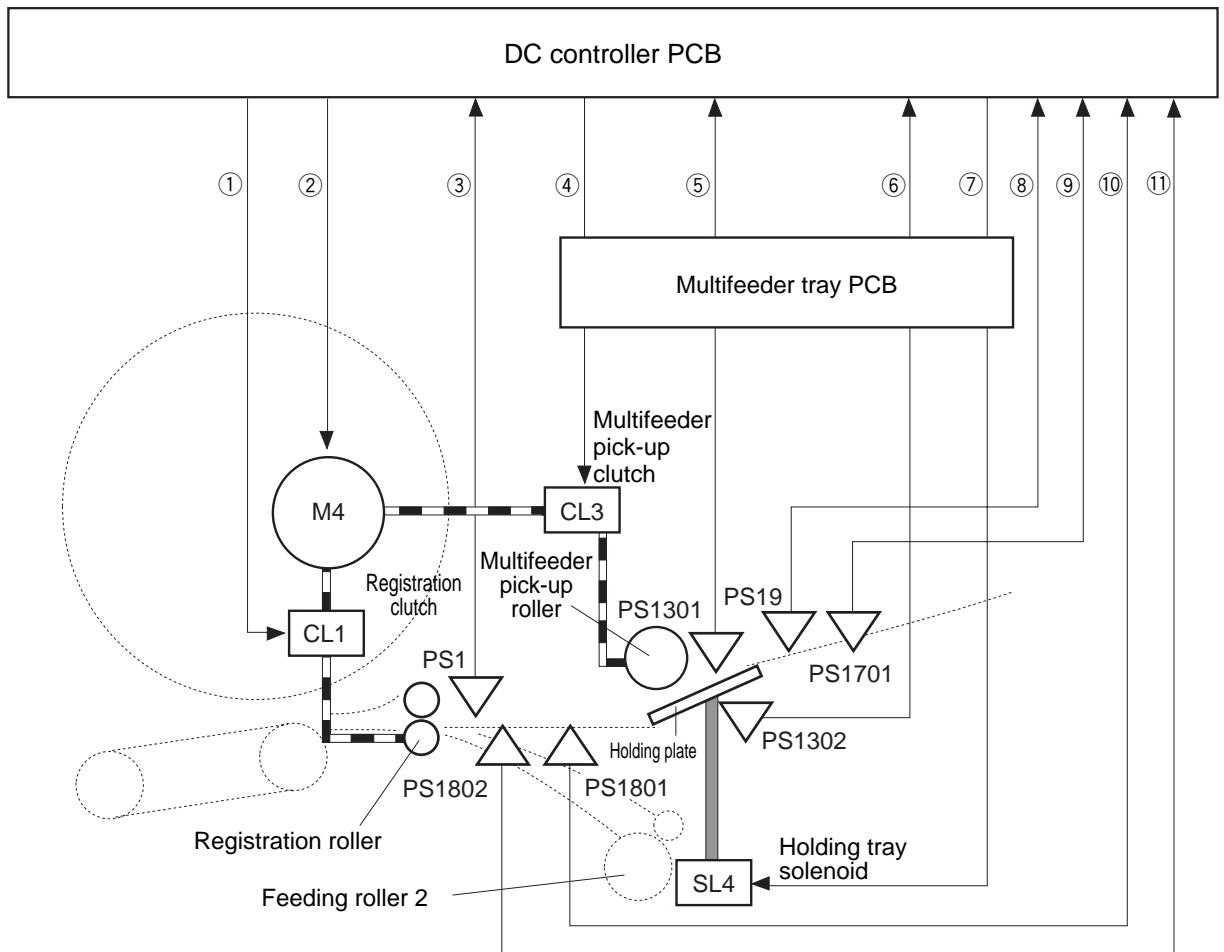

- | | |
|---|---|
| ① : Registration clutch drive signal (REGCLD*) | SL4: Holding plate solenoid |
| ② : Main motor drive signal (MON*) | CL1: Registration clutch |
| ③ : Registration paper detection signal (REGS*) | CL3: Multifeeder pick-up clutch |
| ④ : Multifeeder tray paper detection signal (MPTCLD*) | PS1: Registration paper sensor |
| ⑤ : Multifeeder tray paper detection signal (MPTPS*) | PS19: Multifeeder tray last sheet sensor |
| ⑥ : Holding plate position detection signal (MPTLS) | PS1301: Multifeeder tray paper sensor |
| ⑦ : Holding tray solenoid drive signal (MPTSOLD*) | PS1302: Holding plate position sensor |
| ⑧ : Multifeeder tray last sheet detection signal (MPDFS*) | PS1701: Multifeeder tray paper width sensor |
| ⑨ : Multifeeder paper width detection signal (MPTWID) | PS1801: Transparency sensor 1 |
| ⑩ : Transparency detection signal 1 (OHPSNS1*) | PS1802: Transparency sensor 2 |
| ⑪ : Transparency detection signal 2 (OHPSNS2*) | |

Figure 5-213

2. Multifeeder Last Sheet Detection

The printer unit is capable of detecting the last sheet from the multifeeder. The feeding distance from the multifeeder tray paper sensor to the registration roller is short; as such, if the last sheet was picked up during continuous printing, writing would start before the DC controller PCB identifies the absence of paper, requiring the printer unit to detect the absence of paper before writing starts and, ultimately, to prevent soiling between the photosensitive drum and the intermediate transfer drum.

The last sheet is detected by monitoring the rotation of the last sheet detecting roll mounted to the multifeeder tray by the multifeeder tray last sheet sensor (P19).

If two or more sheets of paper exist on the multifeeder tray, the last paper detecting roll will not rotate during pick-up operation. When the last sheet is picked up, however, the sheet will rotate the last sheet detecting roll, causing the output of the last paper sensor to change between '1' and '0'. In response, the DC controller PCB will assume that the last sheet has been picked up, and communicate the fact (absence of paper) to the printer board*1 to stop writing the next image.

*1 Reader controller PCB (when making prints with the reader unit installed).

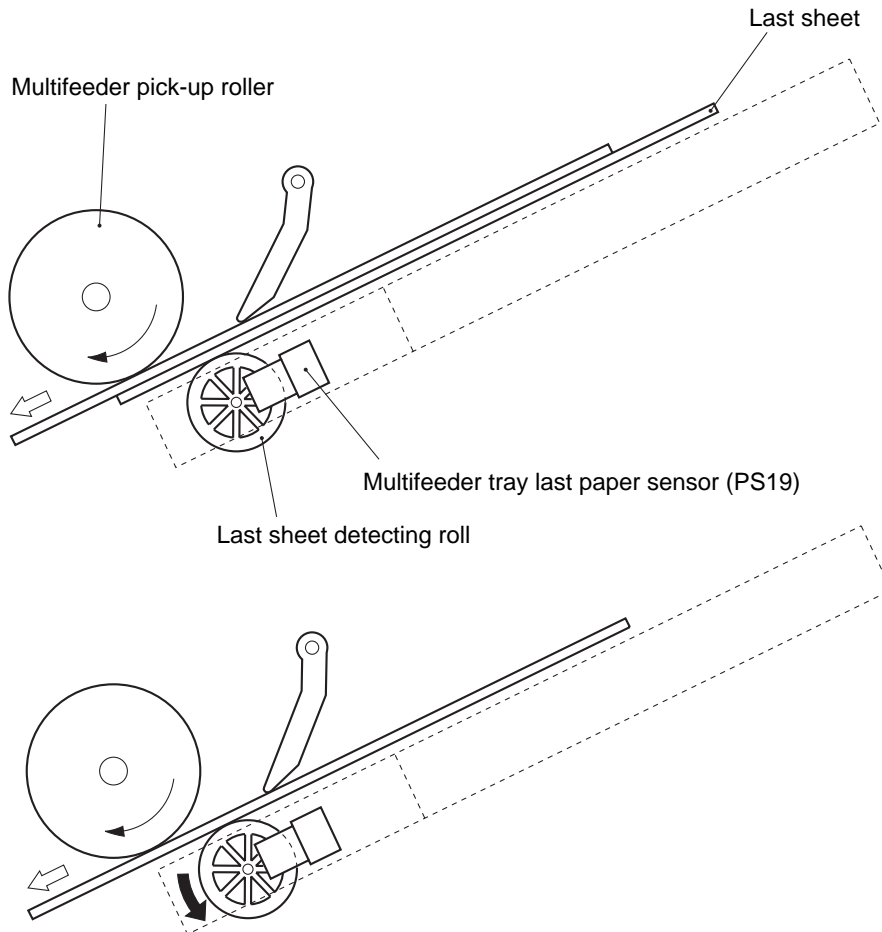

Figure 5-214

C. Controlling the Pick-Up Motor

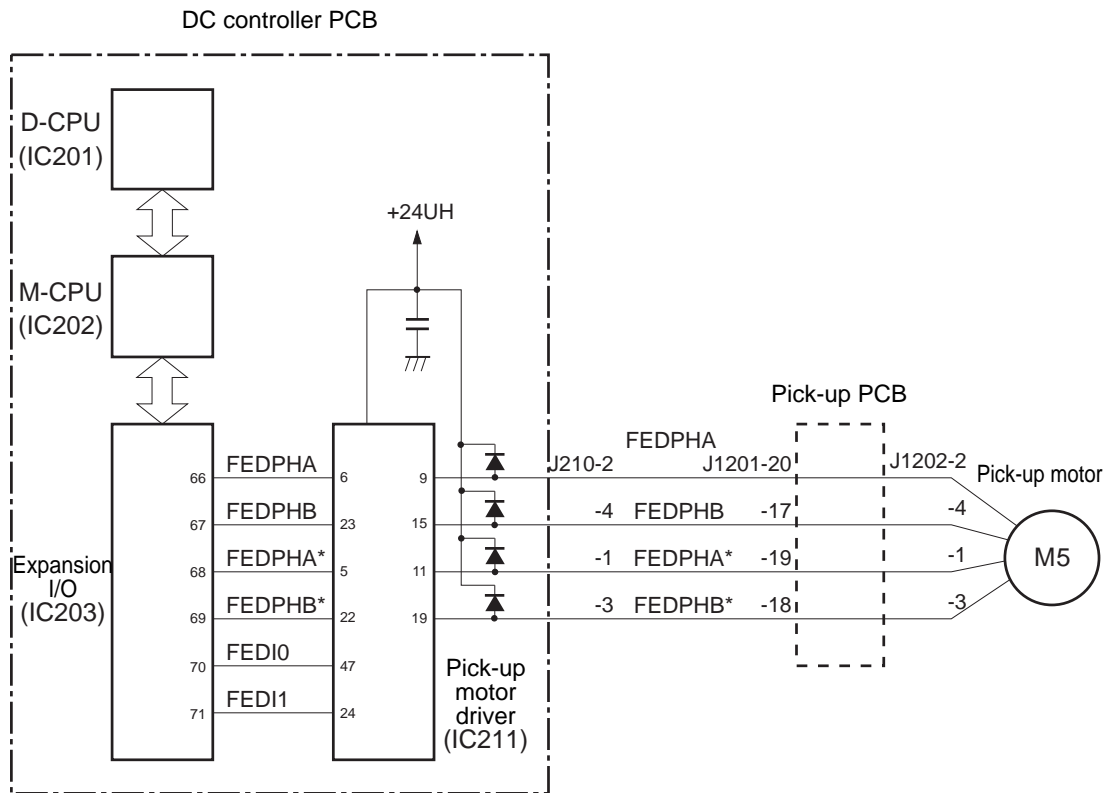

Figure 5-215

The pick-up motor is a 2-phase stepping motor, and is controlled by the pick-up motor driver (IC211) for pick-up operation.

When the print sequence command is received from the D-CPU (IC202), the M-CPU (IC201) sends the pick-up motor drive signal (FEDPHA, FEDPHA*, FEDPHB, FEDPHB*) and the pick-up motor current level switch signal (FEDI0, FEDI1) to the pick-up motor driver (IC211) by way of the expansion I/O (IC203).

The pick-up motor driver (IC211) uses these signals to supply the motor with the drive signals (FEDPHA, FEDPHA*, FEDPHB, FEDPHB*) to switch among three motor speeds: for normal clockwise rotation, normal counterclockwise rotation, and high-speed counterclockwise rotation.

The motor torque varies in relation to rotation speed, requiring variation of the current level, and the printer unit uses combinations of FEDI0 and FEDI1 signals to find the appropriate current level for each motor speed.

Table 5-202 shows the relationship between the combinations of FED10 and FED11 signal states and speeds:

	FED10	FED11
Cassette 1 pick-up (normal CW)	L	L
Cassette 2 pick-up (1st sheet; normal CCW)	H	L
Cassette 2 pick-up (2nd sheet and after; high-speed CCW)	L	H
Stationary	H	H

Table 5-202

III. FEEDING/DELIVERY ASSEMBLY

A. Outline

The printer unit switches between face-up and face-down delivery paths using the delivery flapper.

The face-up delivery roller and the face-down delivery roller are driven by the main motor (M4); when the face-up solenoid drive signal (FUSLD*) goes '0', the face-up solenoid (SL2) operates the face-up flapper so that it will face the face-up tray, delivering paper to the face-up tray. When FUSLD* is '1', on the other hand, paper will be delivered to the face-down tray found at the top of the printer unit.

Paper on the face-down tray is checked by the face-down tray delivery sensor (PS11). When the face-down tray becomes full of paper, the condition is identified by the face-down tray full sensor (PS10).

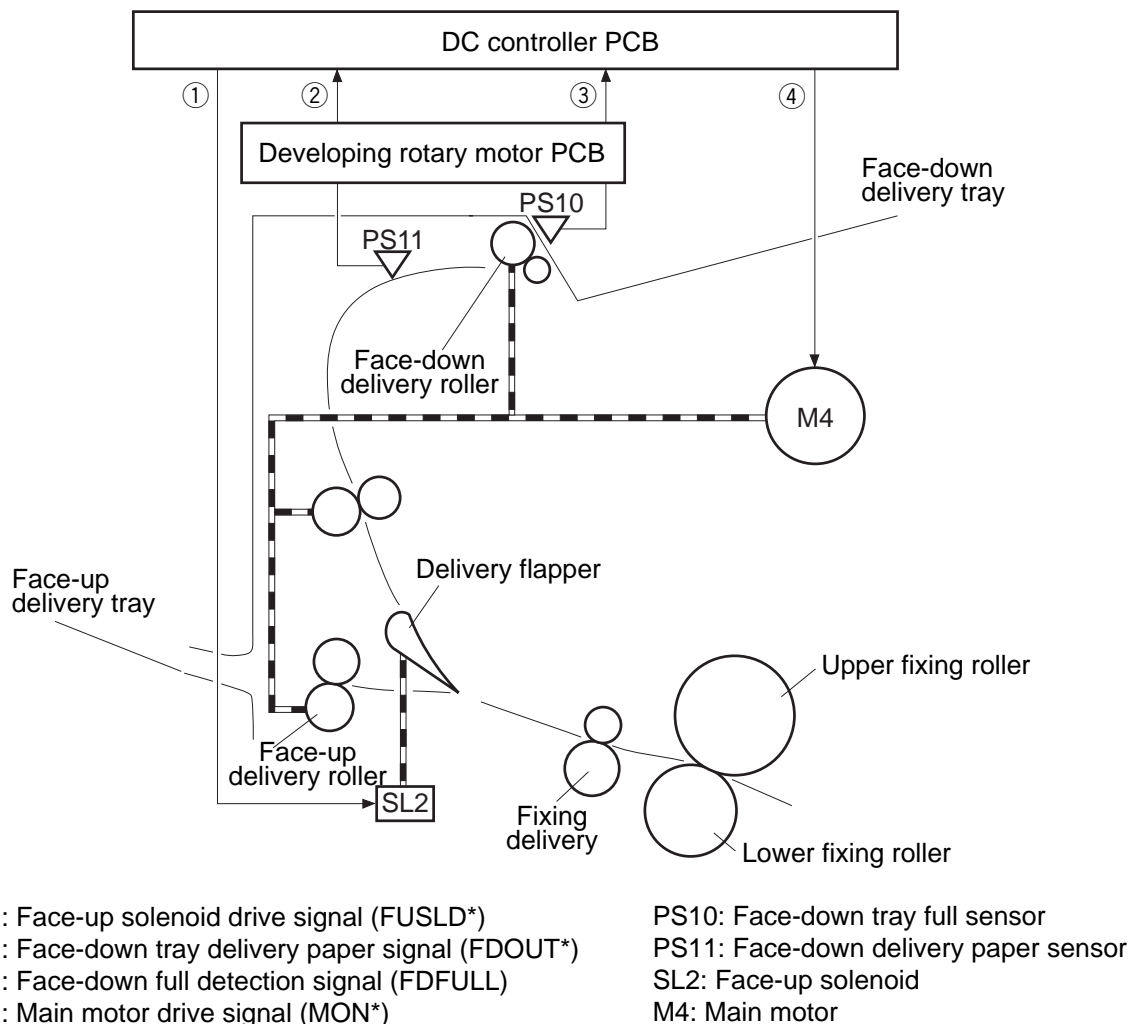

Figure 5-301

IV. DUPLEXING UNIT

A. Outline

Paper is moved to the copier's reversing assembly through the duplexing unit by the duplexing flapper.

It is then shifted by the reversing roller and moved inside the duplexing unit. When it has been adjusted for horizontal registration by the horizontal registration guide inside the duplexing unit (p. 5-26), it is moved by the duplexing feeding roller to the duplexing unit stacking assembly.

The reversing roller rotates in response to the drive from the duplexing motor (M8). The duplexing feeding roller 1 and the duplexing feeding roller 2 are rotated by the drive from the duplexing motor (M8) controlled by the duplexing feeding clutch.

The duplexing motor (M8) is a stepping motor, and is controlled to rotate clockwise and counterclockwise by the microprocessor (CPU) on the duplexing driver PCB; it is also controlled to rotate at normal or high speed.

The horizontal registration guide is shifted by the drive from the horizontal registration motor (M7).

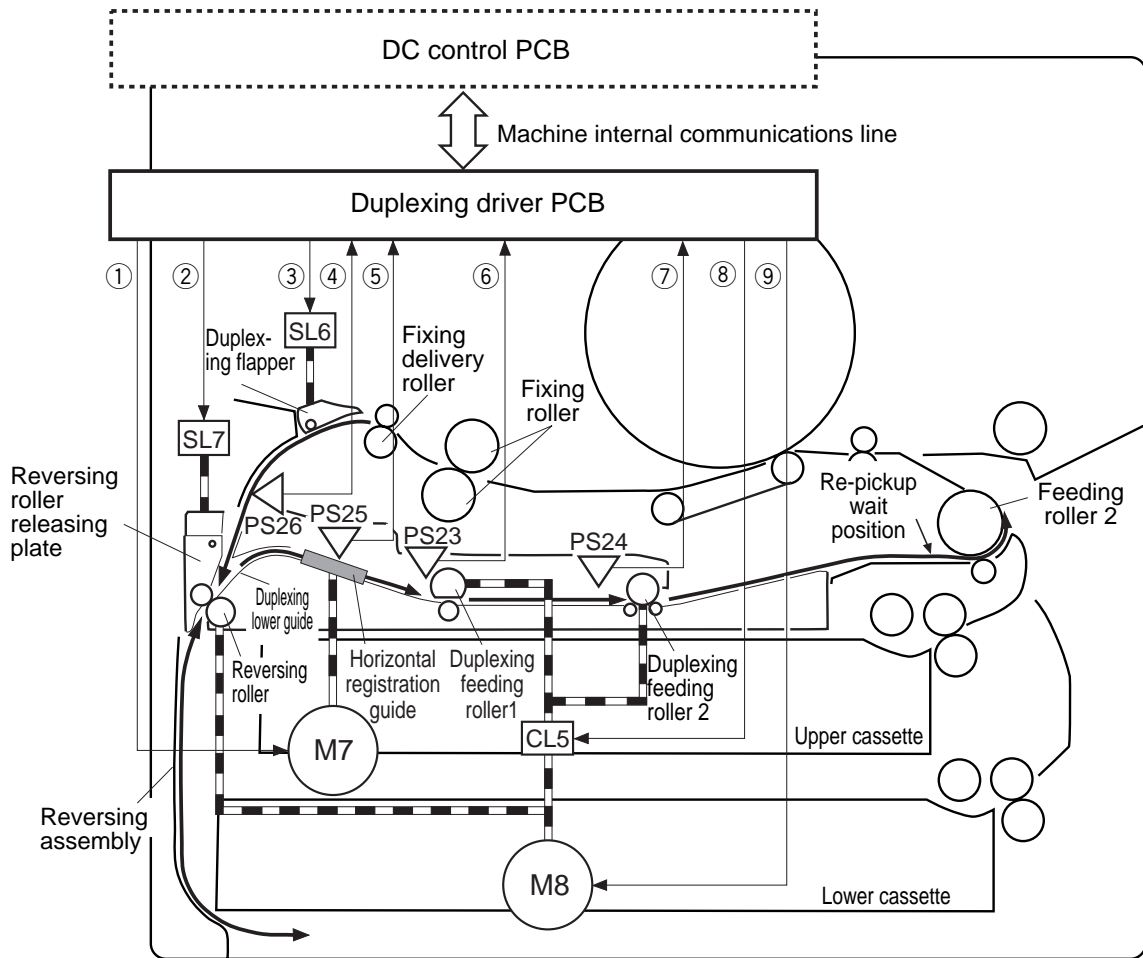

- | | |
|--|---|
| ① : Horizontal motor drive signal | M7: Horizontal registration motor |
| ② : Reversing roller releasing solenoid drive signal (PRRESLD*) | M8: Duplexing motor |
| ③ : Duplexing flapper solenoid drive signal (DUPSLD*) | SL6: Duplexing flapper solenoid |
| ④ : Reversal paper detection signal (SWBKS*) | SL7: Reversing roller releasing solenoid |
| ⑤ : Horizontal registration guide home position detection signal (HREGS) | CL5: Duplexing feeding clutch |
| ⑥ : Duplexing feeding roller 1 home position detection signal (DRPS) | PS23: Duplexing feeding roller 1 home position sensor |
| ⑦ : Duplexing unit paper detection signal (DUPPS*) | PS24: Duplexing unit paper sensor |
| ⑧ : Duplexing feeding clutch drive signal (DUPCLD*) | PS25: Horizontal guide home position sensor |
| ⑨ : Duplexing motor drive signal | PS26: Reversal paper sensor |

Figure 5-401

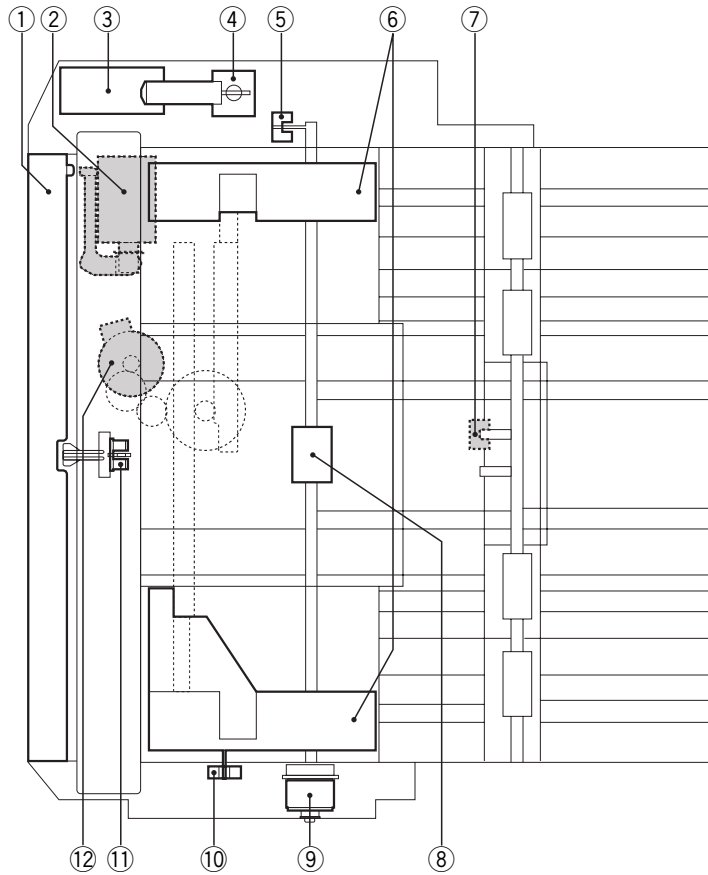

- | | |
|---|--|
| ① : Reversing roller releasing plate | ⑦ : Duplexing unit paper sensor |
| ② : Reversing roller releasing solenoid | ⑧ : Duplexing feeding roller 1 |
| ③ : Duplexing motor | ⑨ : Duplexing feeding clutch |
| ④ : Duplexing flapper solenoid | ⑩ : Horizontal registration guide home position sensor |
| ⑤ : Duplexing feeding roller 1 home position sensor | ⑪ : Reversal paper sensor |
| ⑥ : Horizontal registration guide | ⑫ : Horizontal registration motor |

Figure 5-402 (top view)

B. Reversing Operation

When the duplexing command arrives from the DC controller PCB, the duplexing driver PCB turns on the duplexing flapper solenoid (SL6), operating the duplexing flapper so that paper will be moved to the duplexing unit.

When the leading edge of paper is detected by the reversal sensor (PS26), the duplexing driver PCB rotates the duplexing motor (M8) counterclockwise (CCW; Note) to move the paper to the machine's reversing assembly.

Then, a specific period of time after the reversal paper sensor (PS26) has detected the trailing edge of the paper, the duplexing driver PCB switches the rotation of the duplexing motor (M8) to clockwise direction to switch the paper path so that paper will be moved along the duplexing lower guide to the feeding roller side of the duplexing unit.

Note:

If paper is not 11x17, A3, B4, or LGL, the duplexing driver PCB first drives the duplexing motor (M8) and then will switch its rotation to high speed to move the paper to the reversing assembly.

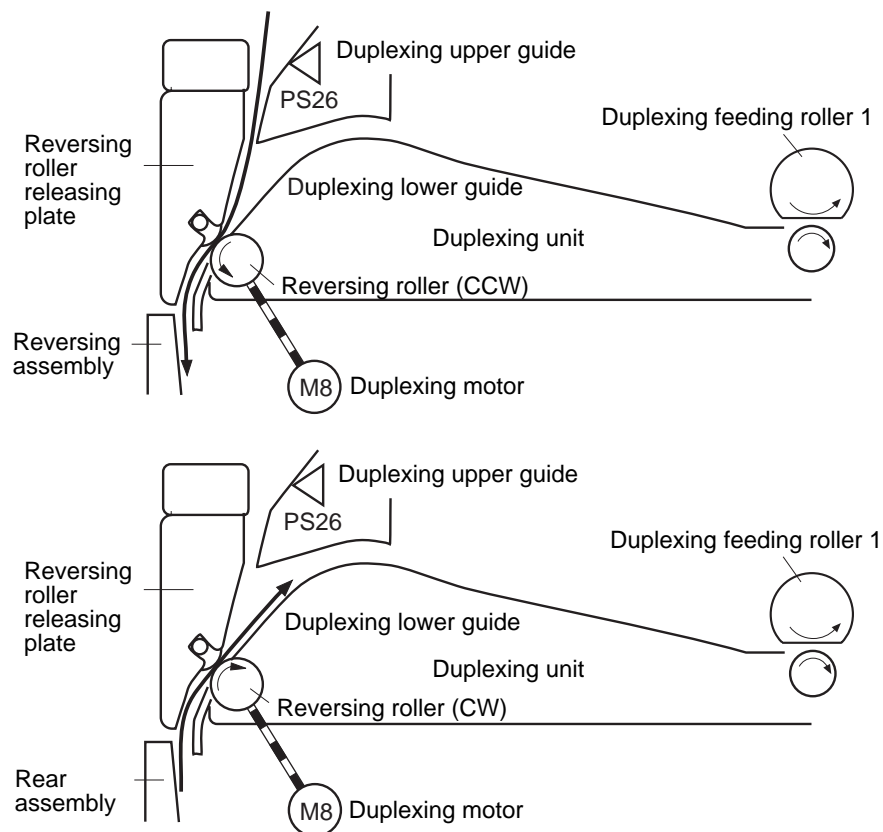

Figure 5-403

C. Horizontal Registration Adjustment

In duplexing mode, the printer unit performs horizontal registration adjustment so that the middle in main scanning direction of a second page will match the middle of the printing area of the drum by butting the horizontal registration guides against both sides of paper.

The presence/absence of the horizontal guide at its home position is checked by the horizontal registration guide home position sensor (PS25).

At power-on, the duplexing driver PCB drives the horizontal registration motor (M7) to move the horizontal registration guide back to its home position. If the horizontal registration guide is already at its home position, it is first moved away from the home position and brought back to it.

When paper is moved into the duplexing unit by the reversing roller rotating clockwise, the duplexing driver PCB checks the duplexing feeding roller 1 to find out if it is at its home position. If not, the duplexing driver PCB turns on the duplexing feeding clutch (CL5) to rotate the duplexing feeding roller 1; after making sure that the roller is at its home position, the PCB turns off the clutch to stop the roller.

A specific period of time after the reversing roller starts to rotate clockwise, the duplexing driver PCB turns on the duplexing feeding clutch (CL5) to rotate the duplexing feeding roller 1. When the duplexing roller 1 is found to be at its home position, the duplexing driver PCB turns off the clutch to stop the roller. At this time, the paper is stopped where it is not in contact with the duplexing feeding roller 1.

If the paper is not A4R, LTRR, or A5, the duplexing driver PCB turns on the reversing roller releasing solenoid (SL7) to free the reversing roller, thereby fully releasing the paper in preparation for horizontal registration adjustment.

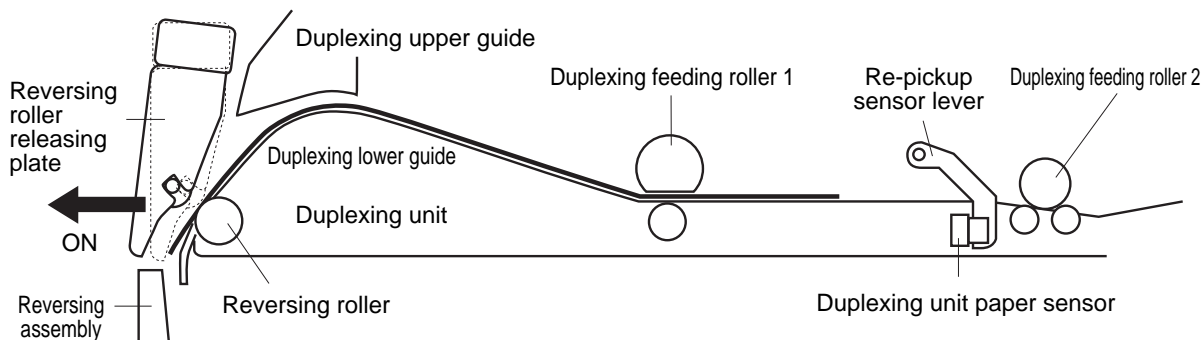

Figure 5-404

When all is ready, the duplexing driver PCB drives the horizontal registration motor for a specific number of pulses based on the paper size data from the DC controller PCB to shift the horizontal registration guide according to the size of the paper for horizontal registration (Note).

The horizontal registration guide returns to its home position a specific period of time after the leading edge of paper is moved and detected by the duplexing unit paper sensor (PS24). The horizontal registration motor (M7) is a stepping motor, capable of controlling the shift distance with high accuracy.

The duplexing driver PCB will identify a fault in the registration guide if the shift distance exceeds the value stored in advance (i.e., the distance the horizontal registration guide moves from its home position), communicating the fact to the printer board*¹ by way of the DC controller PCB.

*¹ Reader controller PCB (when making prints with the reader unit installed).

Reference: _____

E055: A fault in the drive of the duplexing unit horizontal registration guide.

Note: _____

If the paper is not A3, 11x17, A4R, LTRR, or B4, the horizontal registration guide must move a longer distance. As such, the duplexing driver PCB drives the horizontal registration motor (M7) while the reversing roller is rotating counterclockwise to move the horizontal registration guide to a point suited to the paper size.

D. Re-Pickup

The duplexing driver PCB turns on the duplexing feeding clutch (CL5) at the end of horizontal registration so as to move paper once gain.

About 0.5 sec after the duplexing unit paper sensor (PS24) has detected the leading edge of paper, the duplexing driver PCB turns of the reversing roller releasing solenoid (SL7; if the paper is not A4R, LTRR, or A5); about 1.0 sec later, it turns off the duplexing feeding clutch (CL5). While keeping the paper at re-pickup wait position, the duplexing driver PCB waits for a re-pickup command from the DC controller PCB.

When the re-pickup command is received from the DC controller PCB, the duplexing driver PCB controls the speed of the duplexing motor (M8) so that it matches the machine's feeding speed; thereafter, it turns on the duplexing feeding clutch (CL5) to move the paper to the machine's feeding assembly.

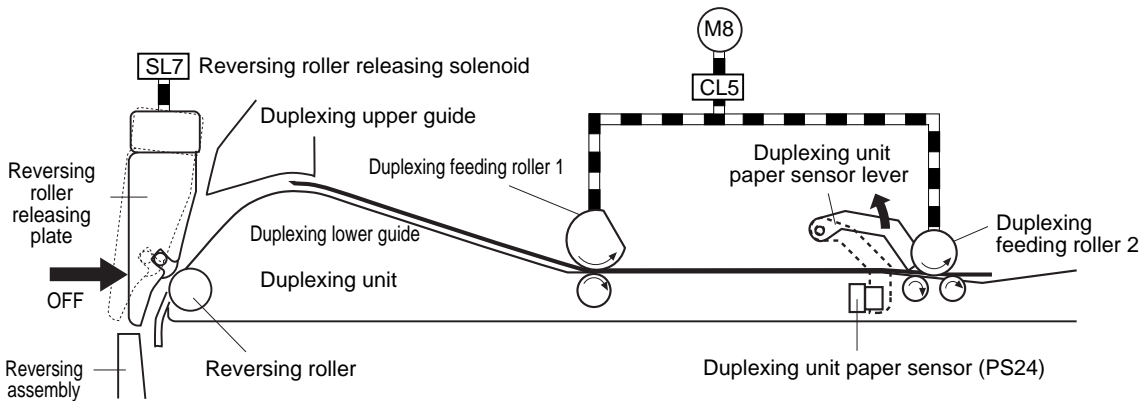

Figure 5-405

V. DETECTING JAMS

A. Detecting Jams in the Printer Unit

The printer unit is equipped with the following paper sensors to check the presence/absence of paper and to find out whether paper is moving normally inside it:

- Registration paper sensor (PS1)
- Pick-up assembly paper sensor (PS17)
- Separation sensor (PS5)
- Face-down tray delivery sensor (PS11)
- Transparency sensor 1/2 (PS1801/PS1802)
- Fixing delivery sensor (PS1903)

A jam is identified in relation to the presence/absence of paper at a specific sensor at such times as programmed in the microprocessor (CPU) in advance.

When the microprocessor identifies a jam, it stops the ongoing printing operation and communicates the fact to the printer board*1.

*1 Reader controller PCB (when making prints with the reader unit installed).

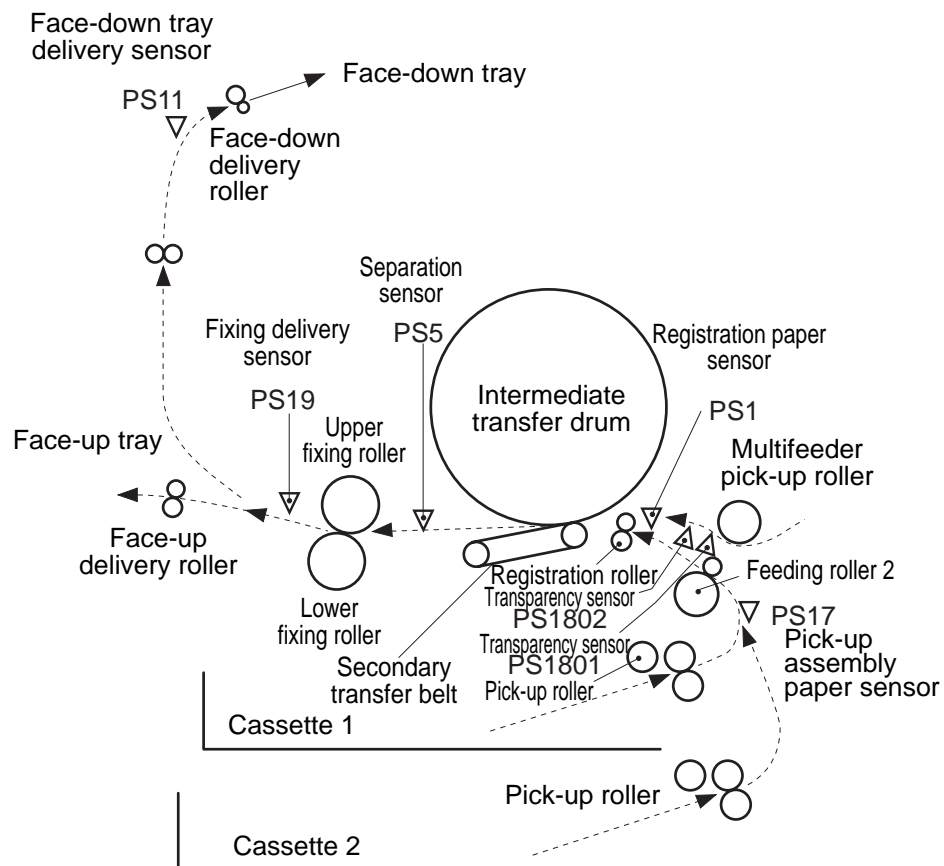

Figure 5-501

1. Pick-Up Delay Jam 1

The CPU will identify a pick-up delay jam 1 if the print paper does not reach the pick-up assembly paper sensor (PS17) a specific period of time (T = about 2.7 sec) after the vertical sync signal (TOP*) has been generated.

2. Pick-Up Delay Jam 2

The CPU will identify a pick-up delay jam 2 if the paper does not reach the registration paper sensor (PS1) a specific period of time (T) after the horizontal sync signal (TOP*) has been generated.

- T = about 2.9 sec if the multifeeder tray is used.
- T = about 3.3 sec if a source other than the multifeeder tray is used.

3. Wrapping on the Intermediate Transfer Drum

The CPU assumes that the paper has wrapped around the intermediate transfer drum if the separation sensor (PS5) does not detect the paper within a specific period of time (T) between 1.5 and 8.7 sec after the registration drive signal (TOPR*) has been generated.

- T = about 0.1 sec (normal mode)
- T = about 0.4 sec (transparency mode)
- T = about 0.3 sec (thick paper mode)

4. Fixing Delivery Delay Jam

The CPU will identify a fixing delivery delay jam if the paper does not reach the fixing delivery sensor (PS1903) within a specific period of time (T) after the registration drive signal (TOPR*) has been generated.

- T = about 3.2 sec (normal mode)
- T = about 12.8 sec (transparency mode)
- T = about 9.6 sec (thick paper mode)

5. Fixing Delivery Stationary Jam

The CPU will identify a fixing delivery stationary jam if the paper does not move past the fixing delivery sensor (PS1903) within a specific time (T) after the sensor has detected the leading edge of the paper.

- T = about 2.4 sec (normal mode, A4R)
- T = about 4.1 sec (normal mode, A3)
- T = about 9.4 sec (transparency mode, A4R), T = about 16.6 sec (transparency mode, A3)
- T = about 7.0 sec (thick paper mode, A4R), T = about 12.4 sec (thick paper mode, A3)

6. Face-Down Delivery Slot Delay Jam

The CPU will identify a face-down delivery slot delay jam if the paper does not reach the face-down tray delivery sensor (PS11) within a specific period of time (T) after the fixing delivery sensor (PS1903) has detected the leading edge of the paper.

- T = about 4.0 sec (normal mode)
- T = about 16.0 sec (transparency mode)
- T = about 12.0 sec (thick paper mode)

7. Face-Down Delivery Slot Stationary Jam

The CPU will identify a face-down delivery slot stationary jam if the paper does not move past the face-down tray delivery sensor (PS11) within a specific period of time (T) after the face-down tray delivery sensor (PS11) has detected the leading edge of the paper.

- T = about 2.4 sec (normal, A4)
- T = about 4.1 sec (normal, A3)
- T = about 9.4 sec (transparency, A4)
- T = about 16.6 sec (transparency, A3)
- T = about 7.0 sec (thick paper, A4)
- T = about 12.4 sec (thick paper, A3)

8. Delivery Excess Length Feeding Jam

The CPU checks the size of paper using the registration paper sensor (PS1), and will stop the printer unit operation if the difference in size between the the result of its detection and the result of later detection is +15 mm or more. If the difference is between +7.5 and 15 mm or -3.7 mm or more, it will discharge the paper as a paper size mismatch.

9. Non-Default Size Feeding Jam

If the transparency sensors 1 and 2 detect a transparency not of a specific size, a non-default size feeding jam is identified.

10. Door Open Jam

If any of the following sensors detects paper when the cover is opened/closed, the CPU will identify a door open jam:

- Registration paper sensor (PS1)
- Pick-up assembly paper sensor (PS17)
- Separation sensor (PS5)
- Face-down tray delivery sensor (PS11)
- Fixing delivery sensor (PS1903)

11. Inside Residual Jam

The CPU will identify an inside residual jam if any of the following sensors detects paper when the paper switch is turned on:

- Pick-up assembly paper sensor (PS17)
- Separation sensor (PS5)
- Face-down tray delivery sensor (PS11)
- Fixing delivery sensor (PS1903)

B. Detecting Jams in the Duplexing Unit

The printer unit is equipped with the following paper sensors to check the presence/absence of paper or to find out whether paper is moving normally:

- Duplexing unit paper sensor (PS24)
- Reversal paper sensor (PS26)

The presence/absence of a jam is checked in relation to the presence/absence of paper at a specific sensor at such times as programmed in the microprocessor (CPU) on the duplexing driver PCB.

When the CPU identifies a jam, it stops the ongoing duplexing feeding operation and, at the same time, communicates the fact to the printer board *1.

*1 Reader controller PCB (when making prints with the reader unit installed).

Note:

T1 and T2 times represent minimum print size and maximum print size.

1. Reversing Assembly Delay Jam

The duplexing driver PCB will identify a reversing assembly delay jam if the paper does not reach the reversal paper sensor (PS26) within a specific time after the duplexing flapper solenoid has turned on.

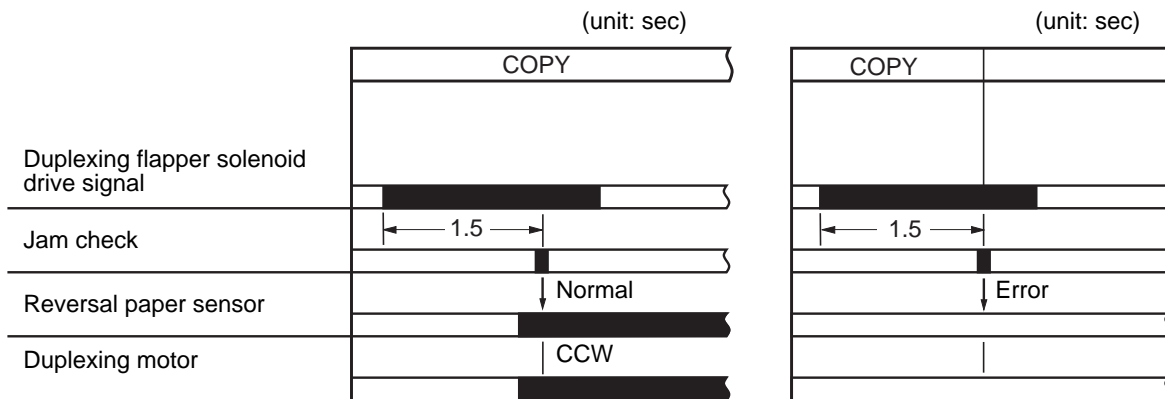
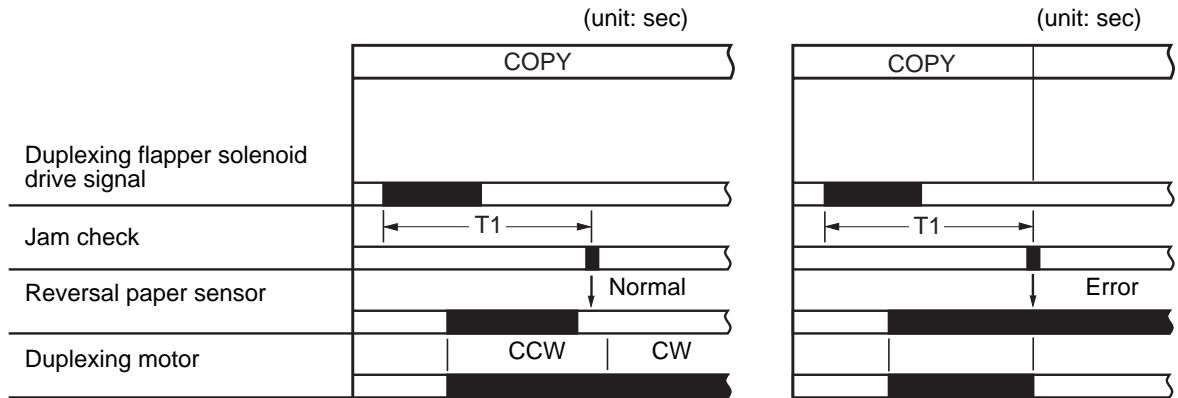

Figure 5-502

2. Reversing Assembly Stationary Jam

The duplexing driver PCB will identify a reversing assembly stationary jam if the paper does not move past the reversal paper sensor (PS26) within a specific period of time aft the duplexing flaper solenoid has turned on.



T1 = about 3.2 sec for A4 (horizontal), about 6.3 sec for LDG.

Figure 5-503

3. Duplexing Feeding Assembly Delay Jam

The duplexing driver PCB will identify a duplexing feeding assembly delay jam if the paper does not reach the duplexing unit paper sensor (PS24) within a specific period of time after the paper has moved past the reversal paper sensor (PS26).

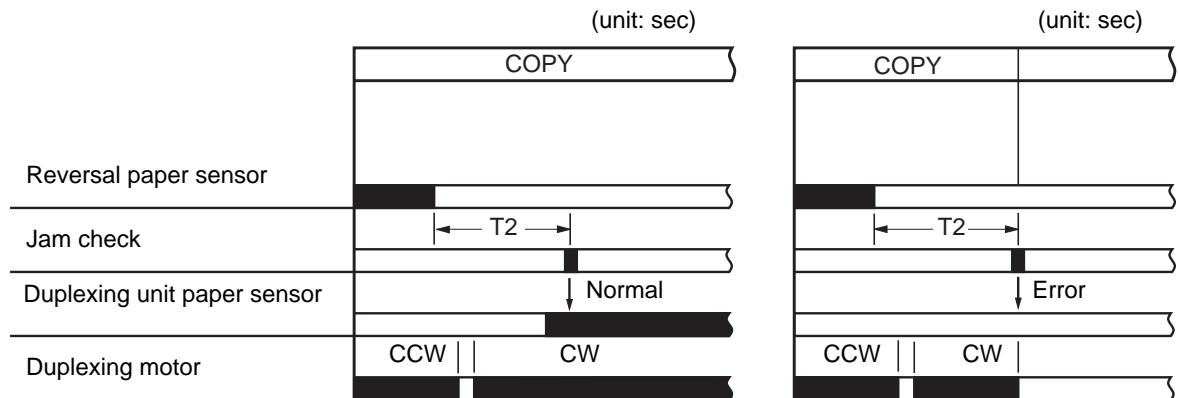

T2 = about 1.7 sec for A4R, about 2.4 sec for 11x17.

figure 5-504

VI. DISASSEMBLY/ASSEMBLY

Make sure of the following when disassembling or assembling the machine:

1. **⚠** When the printer unit power switch is turned off, the fans will operate for about 30 min to cool the machine (so as to prevent caking of toner). Be sure to perform either of the following in addition to disconnecting the power plug:
 - Wait for 30 min after turning off the printer unit power switch; or
 - Turn off the printer unit power switch, and remove the fixing assembly of the printer unit.
2. Assemble the parts by reversing the steps used to disassemble them, unless otherwise mentioned.
3. Identify the screws by type (length, diameter) and location.
4. Do not leave out the toothed washer that comes with one of the mounting screws on the rear cover to protect against static electricity.
5. Do not leave out the washer that comes with the screw used for the grounding wire and the varistor to ensure electrical continuity.
6. Do not operate the machine with any of its parts removed, unless otherwise mentioned.
7. **⚠** Do not throw a toner cartridge into fire. It may explode.
8. Keep any toner cartridge in a protective cover whenever it has been taken out of the printer unit for disassembly/assembly work even for a short time.
9. Remove the cartridge and the intermediate transfer drum before disassembly/assembly work or moving the machine.
10. Touch the copier's metal section before starting the work to discharge the build-up of static electricity so as to prevent static damage before handling any PCBs.
11. To slide out the printer unit from the rack (if the reader unit is also mounted to the rack), pull halfway out the two side pins at the bottom of the rack (middle pin orientation *), and then remove the printer unit fixing member from the left of the printer unit. Be sure also to remove the printer side power cord and the interface cable.

For removal of the external covers of the printer unit, see IV.A. "External Covers of the Printer Unit" in Chapter 3.

A. Pick-Up Assembly

1. Removing the Pick-Up Assembly

- 1) Slide out the cassette 1/2.
- 2) Perform the steps on p. 3-16 to remove the rear cover assembly.
- 3) Perform the steps on p. 5-42 to remove the multifeder pick-up assembly.
- 4) Perform the steps on p. 5-40 to remove the registration roll assembly.
- 5) Open the pick-up cassette cover, and detach the strap.

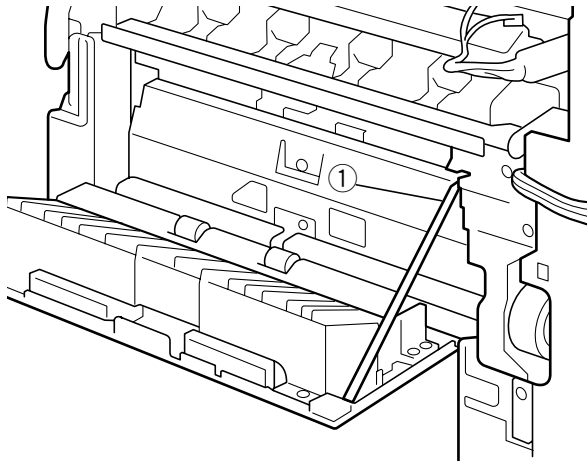

① Strap

Figure 5-601

- 6) Remove the four screws, and detach the pick-up cassette cover.

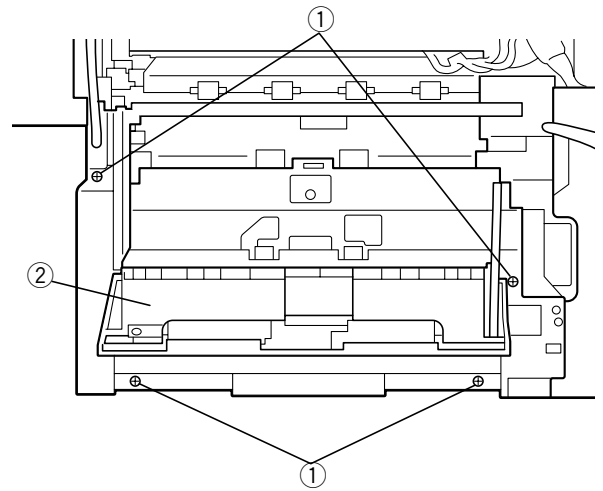

- ① Screws
- ② Pick-up cassette cover

Figure 5-602

- 7) Disconnect the connector.

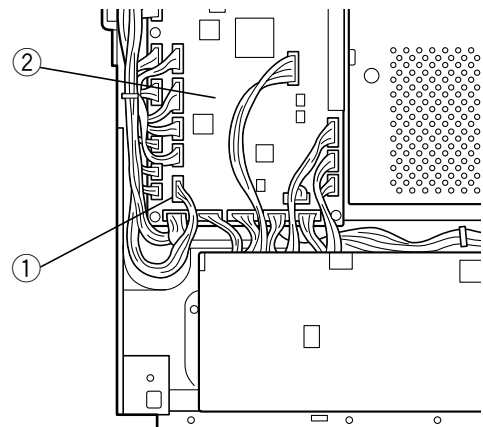

- ① Connector
- ② DC control PCB

Figure 5-603

- 8) Remove the four screws, and detach the pick-up assembly.

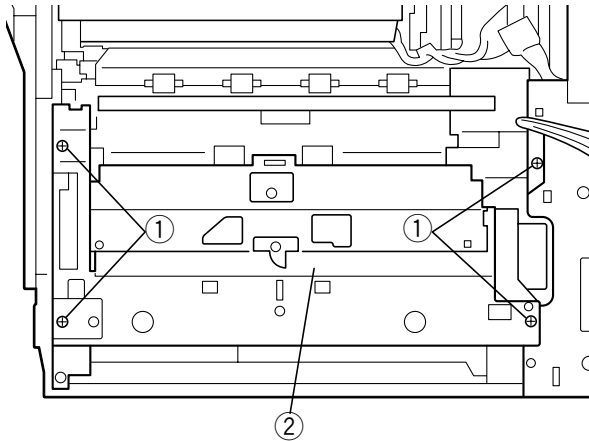

- ① Screws
② Pick-up assembly

Figure 5-604

Note:

1. If you are replacing any of the parts of the pick-up assembly, be sure to remove the pick-up roller, feeding roller, and separation roller first to avoid soiling them with grease. Further, take care not to soil the paper feeding guide with grease.
2. If you are replacing the gears shown in Figure 5-605, be sure to apply grease to prevent abnormal noise. Use the appropriate grease (SHV-2), and never use any that is not recommended.
To apply, put a small amount (size of a small bean) over three or more contiguous teeth.

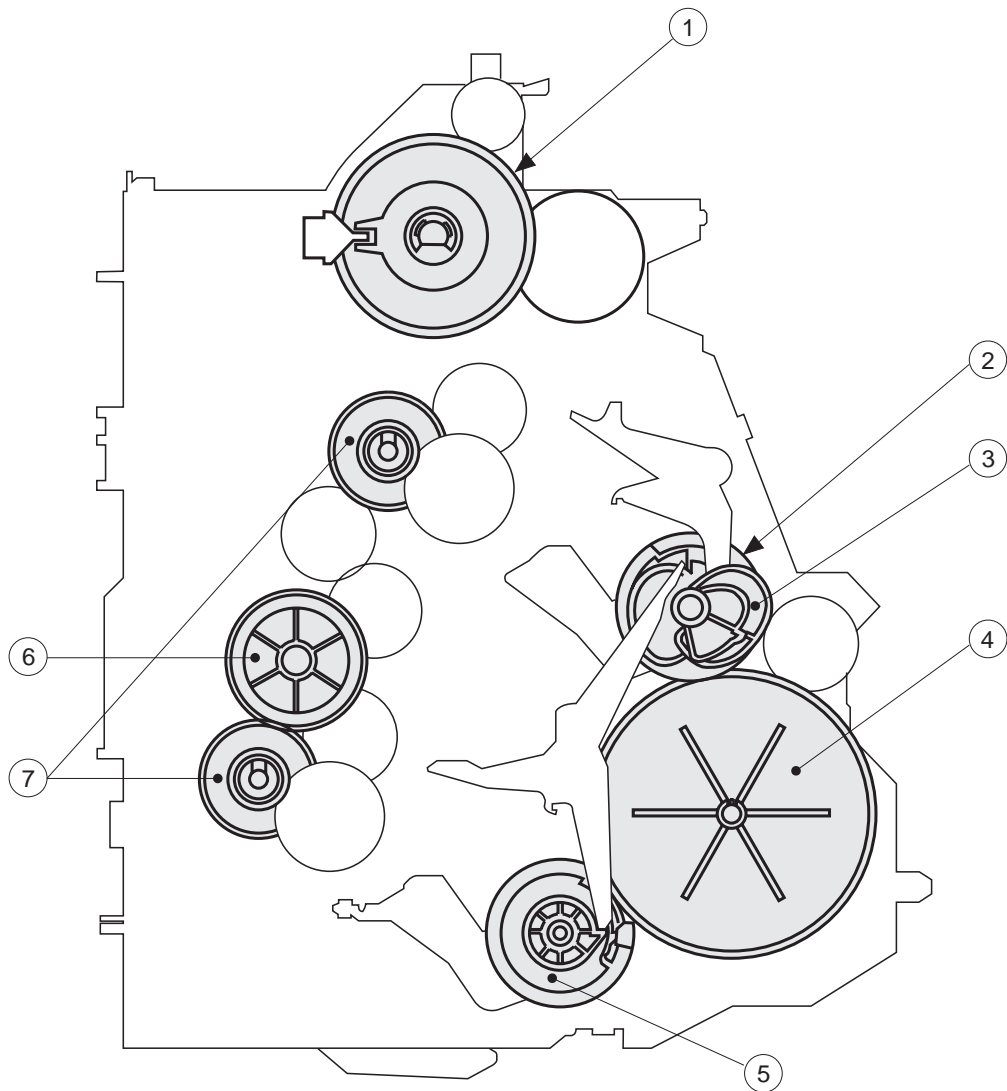

- ① 57T gear
- ② Lift-up cam
- ③ Pick-up cam
- ④ 100T gear
- ⑤ Lift-up cam (lower)
- ⑥ 31T/47T gear
- ⑦ 20T/41T gear

Figure 5-605

2. Removing the Pick-Up Motor

- 1) Disconnect the connector.
- 2) Remove the two screws, and slide the pick-up motor in the direction of the arrow to detach.

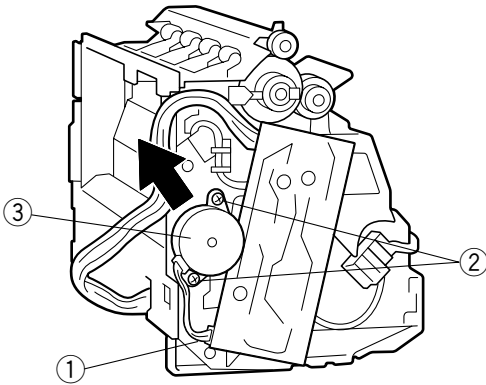

- ① Connector
- ② Screws
- ③ Pick-up motor

Figure 5-606

3. Removing the Feeding Clutch

- 1) Disconnect the connector.
- 2) Remove the screw, and disengage the two claws; then, detach the pick-up PCB.

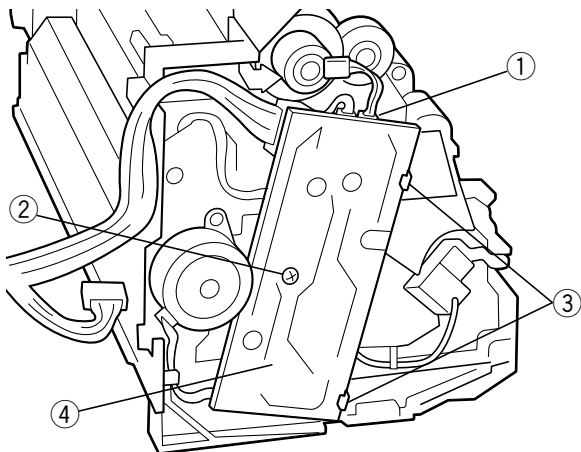

- ① Connector
- ② Screw
- ③ Claws
- ④ Pick-up PCB

Figure 5-607

- 4) Remove the E-shaped stop ring, and detach the feeding clutch.

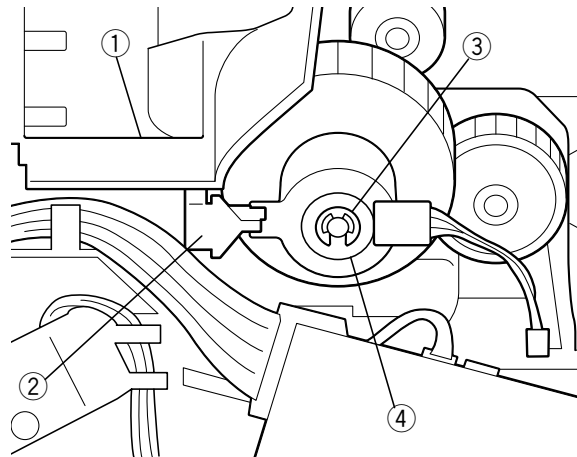

- ① Claw
- ② Clutch fixing plate
- ③ E-shaped stop ring
- ④ Feeding clutch

Figure 5-608

4. Removing the Cassette Pick-Up Solenoid

- 1) Disconnect the connector.
- 2) Remove the screw, and detach the cassette pick-up solenoid.

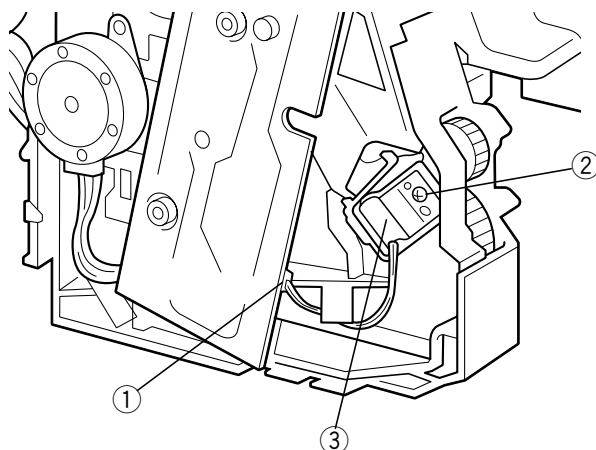

- ① Connector
- ② Screw
- ③ Cassette pick-up solenoid

Figure 5-609

- 3) Disengage the claw, and detach the clutch fixing plate.

B. Delivery Assembly

1. Removing the Delivery Assembly

- 1) Perform the steps on p. 3-14 to remove the upper cover.
- 2) Perform the steps on p. 3-15 to remove the side cover.
- 3) Perform the steps on p. 3-17 to remove the left cover.
- 4) Remove the two screws, and disconnect the connector; then, detach the upper stay.

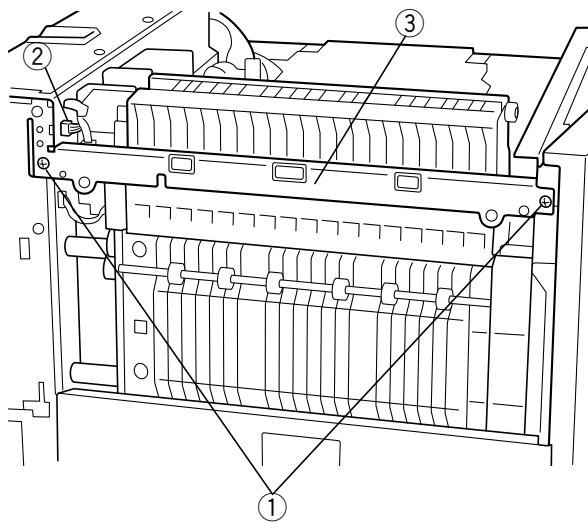

- ① Screws ② Connector
③ Upper stay

Figure 5-610

- 5) Remove the two screws, and detach the delivery assembly.

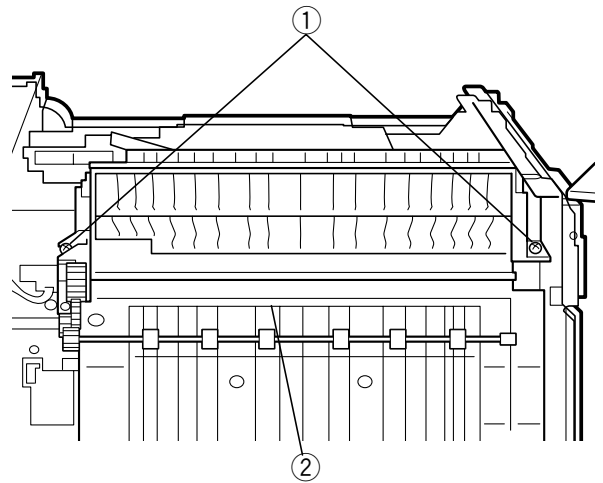

- ① Screws
② Delivery assembly

Figure 5-611

C. Feeding Assembly

1. Removing the Feeding Assembly

- 1) Perform the steps on p. 5-39 to remove the delivery assembly.
- 2) Remove the two screws, and remove the lower stay.

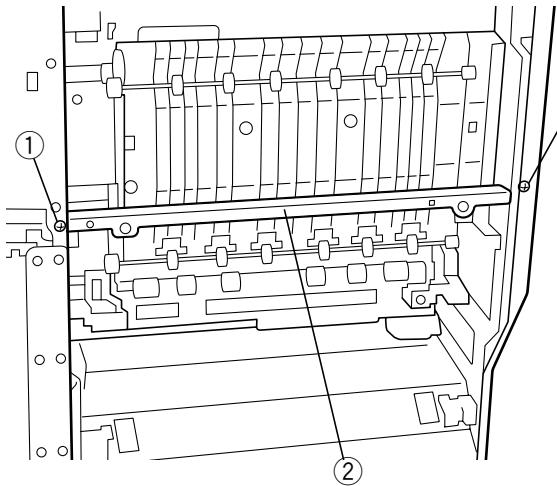

- ① Screw ② Lower stay

Figure 5-612

- 3) Remove the six screws, and detach the feeding assembly.

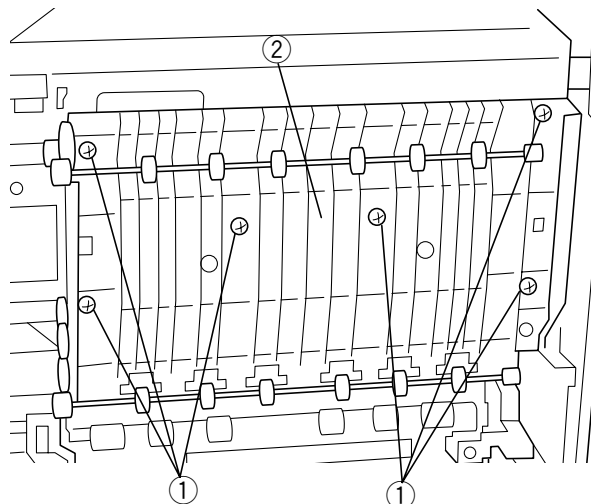

- ① Screws ② Feeding assembly

Figure 5-613

D. Registration Roller Assembly

1. Removing the Registration Roller Assembly

- 1) Perform the steps on p. 4-50 to remove the secondary transfer belt assembly.
- 2) Perform step 3) on p. 3-21 for the inside cover 4 to remove the jam removal knob.
- 3) Disengage the two claws, and detach the gear cover.

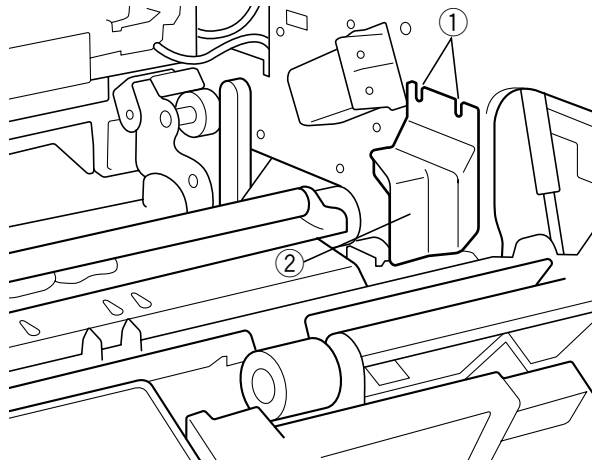

- ① Claws ② Gear cover

Figure 5-614

- 4) While opening the registration roller guide and the jam guide, remove the four screws and disconnect the connector; then, detach the registration roller assembly.

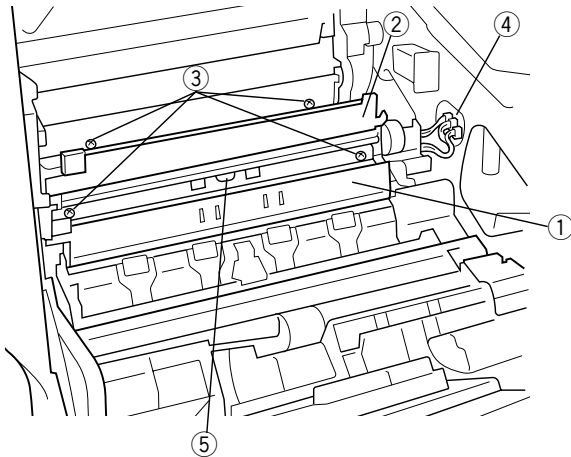

- ① Registration roller guide
- ② Jam guide
- ③ Screws
- ④ Connector
- ⑤ Registration roller assembly

Figure 5-615

Caution:

When replacing each part of the registration roller assembly, take extra care not to touch the sensor window.

2. Removing the Registration Clutch

- 1) Remove the E-shaped stop ring, and detach the registration clutch.

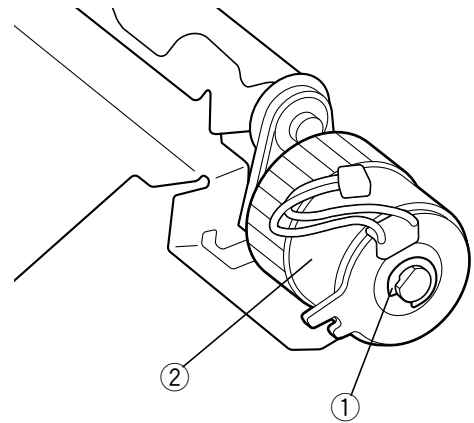

- ① E-shaped stop ring
- ② Registration clutch

Figure 5-616

3. Registration Lower Roller

- 1) Remove the spring, E-shaped stop ring, and bushing.

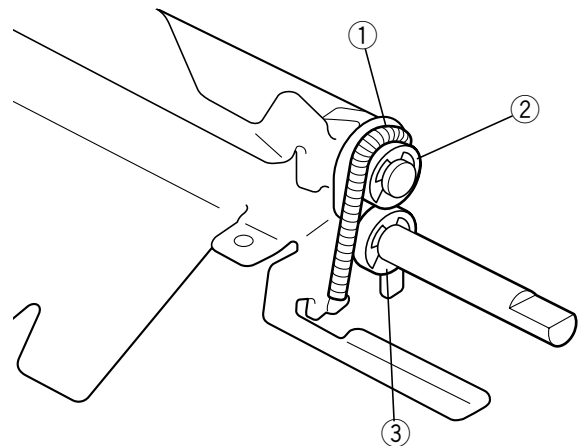

- ① Spring
- ② E-shaped stop ring
- ③ Bushing

Figure 5-617

- 3) Disengage the claw, and remove the gear; then, remove the spring, E-shaped stop ring, and bushing to detach the registration lower roller.

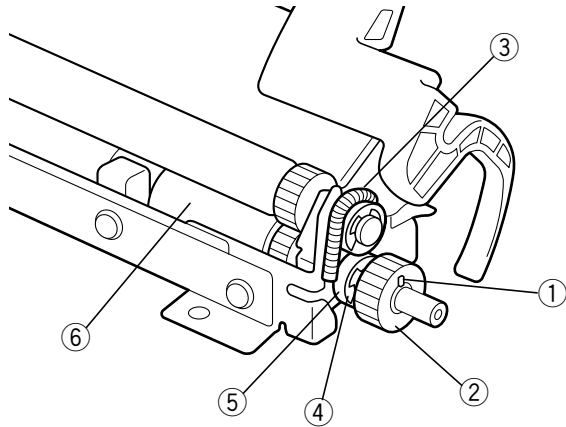

- ① Claw
- ② Gear
- ③ Spring
- ④ E-shaped stop ring
- ⑤ Bushing
- ⑥ Registration lower roller

Figure 5-618

E. Multifeeder Pick-Up Assembly

1. Removing the Multifeeder Pick-Up Assembly

- 1) Perform the steps on p. 3-14 to remove the front right cover.
- 2) Perform the steps on p. 3-16 to remove the rear cover.
- 3) Open the right cover.
- 4) Perform the steps on p. 4-54 to remove the video interface PCB.
- 5) Disconnect the four connectors.

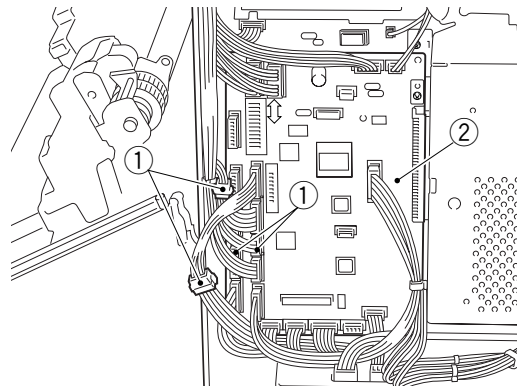

- ① Connector
- ② DC controller PCB

Figure 5-619

- 6) Remove the screw, and disengage the two claws; then, remove the gear cover.

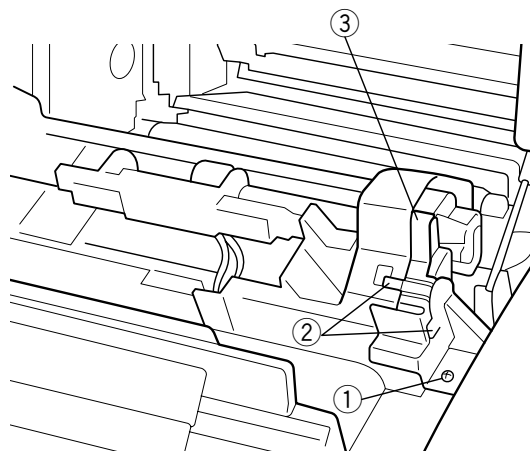

- ① Screw
- ② Claws
- ③ Gear cover

Figure 5-620

- 7) Extend the rod, and remove it from the rod holder of the multifeeder pick-up assembly.

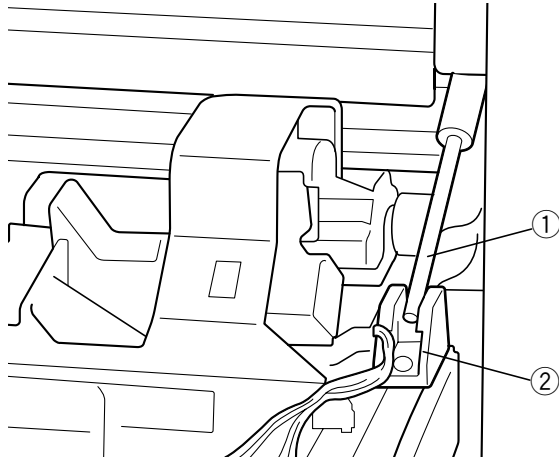

- ① Rod ② Rod holder

Figure 5-621

- 8) Remove the screw, and detach the rod holder cover.

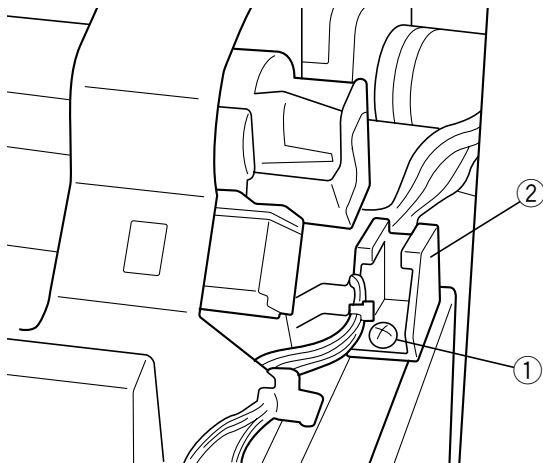

- ① Screw
② Rod holder cover

Figure 5-622

- 9) Remove the E-shaped stop ring.

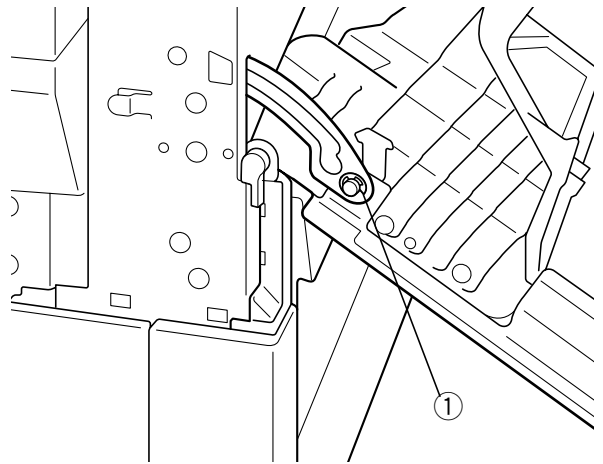

- ① E-shaped stop ring

Figure 5-623

- 10) Turn the fixing hook in the direction of the arrow; then, lift the multifeeder pick-up assembly together with the right cover slightly, and slide it to the left to detach.

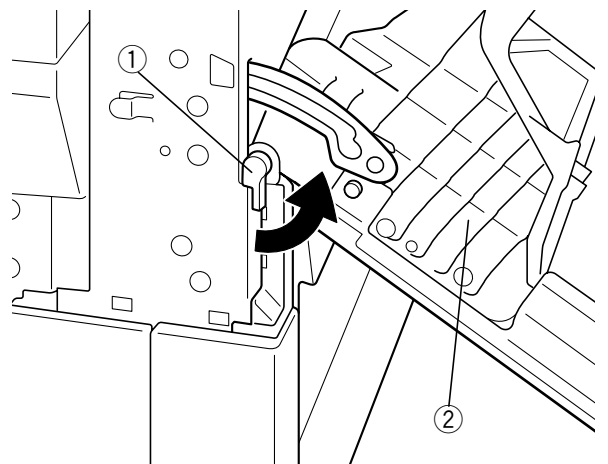

- ① Fixing hook
② Multifeeder pick-up assembly

Figure 5-624

11) Remove the three screws, and disengage the two claws; then, disconnect the connector, and detach the multifeeder pick-up assembly.

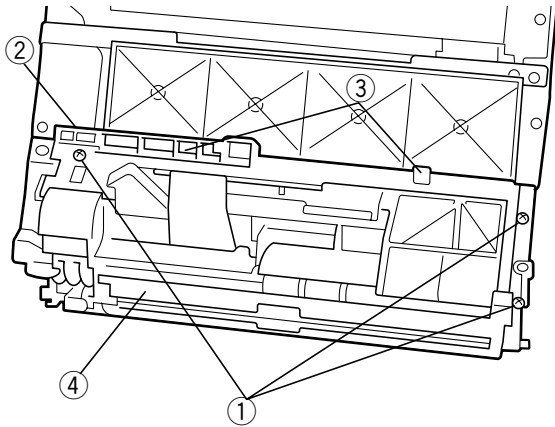

- ① Screws
- ② Connector
- ③ Claws
- ④ Multifeeder pick-up assembly

Figure 5-625

F. Multifeeder Tray Pick-Up Roller

1. Removing the Multifeeder Tray Pick-Up Roller

- 1) Open the right cover.
- 2) While pushing the holding plate and the separation pads, pull out the multifeeder pick-up roller by holding the knob on the roller.

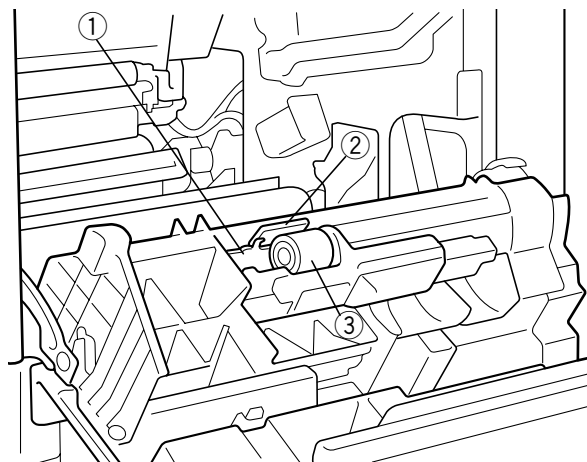

- ① Holding plate
- ② Multifeeder separation pad
- ③ Multifeeder pick-up roller

Figure 5-626

G. Multifeeder Tray Separation Pad

1. Removing the Multifeeder Separation Pad

- 1) Perform the steps on p. 5-44 to remove the multifeeder pick-up roller.
- 2) Remove the separation pad using a flat-blade screwdriver.

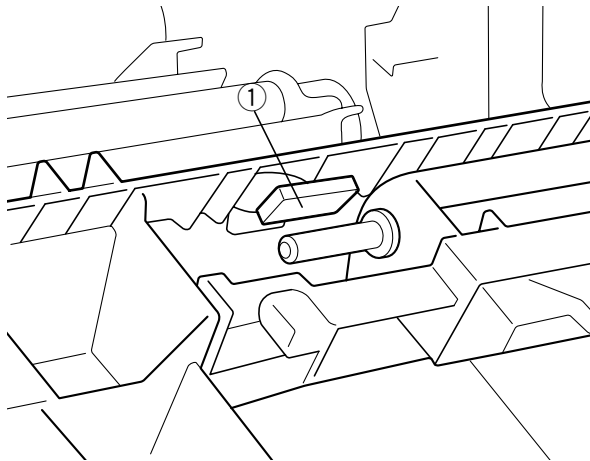

① Separation pad

Figure 5-627

H. Cassette Pick-Up, Feeding, and Separation Rollers

1. Removing the Cassette Pick-Up, Feeding, and Separation Rollers

- 1) Slide out the cassette 1, and take it out while shifting up the blue lever.

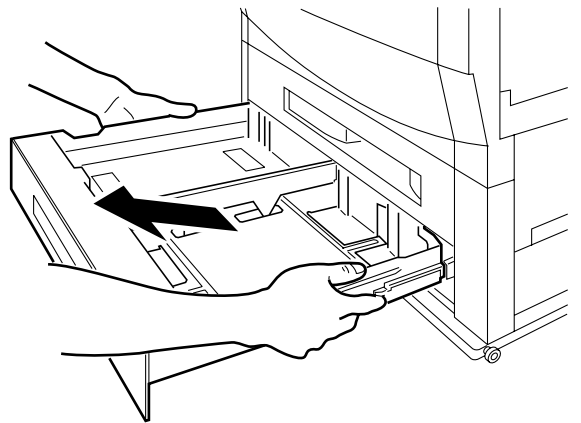
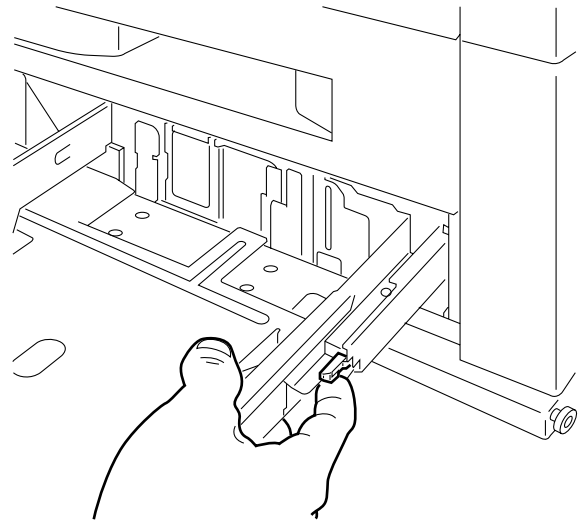

Perform the same for the cassette 2.
Figure 5-628

- 2) Holding the knob, remove each roller from the printer unit.

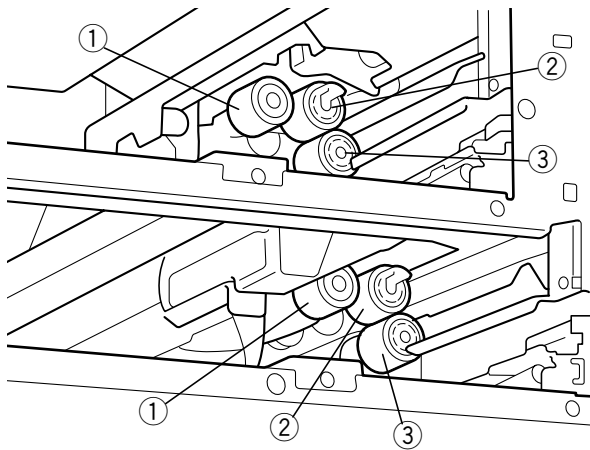

- ① Cassette pick-up roller
- ② Cassette feeding roller
- ③ Cassette separation roller

Figure 7-629

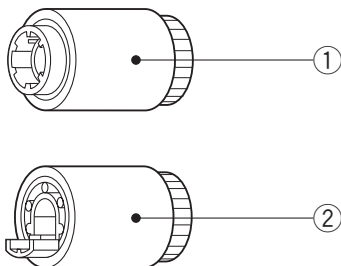

- ① Cassette pick-up roller
- ② Cassette feeding roller/Cassette separation roller

Figure 5-630

Note: _____
 When replacing the cassette feeding roller or the cassette separation roller, be sure to replace them at the same time.

I. PCBs

1. Removing the Pick-Up PCB

- 1) Perform the steps on p. 5-35 to remove the pick-up assembly.
- 2) Remove the screw, disengage the two claws, and disconnect the six connectors; then, detach the pick-up PCB.

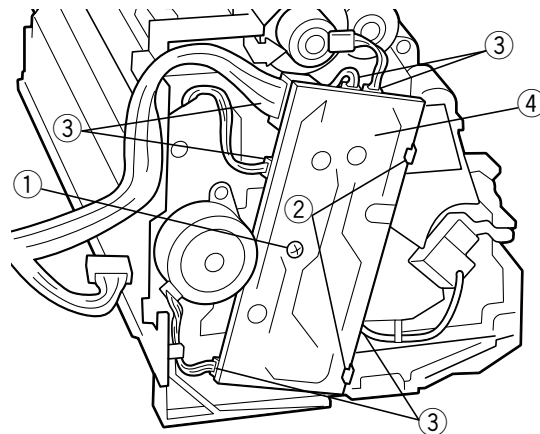

- ① Screw
- ② Claws
- ③ Connectors
- ④ Pick-up PCB

Figure 5-631

2. Cassette 1 Last Sheet Sensor

- 1) Remove the cassette 1/2.
- 2) Disengage the four claws, and disconnect the connector; then, remove the cassette 1 last sheet sensor.

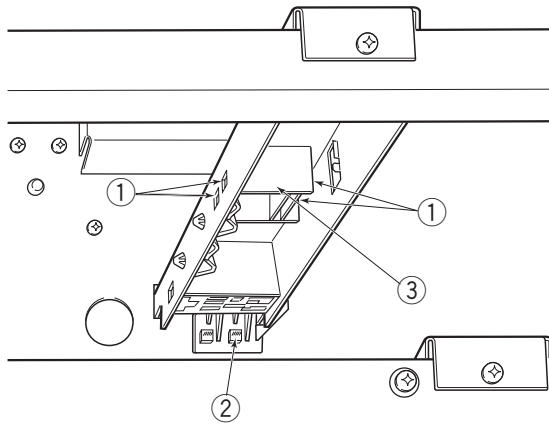

- ① Claws
- ② Connector
- ③ Cassette 1 last sheet sensor

Figure 5-632

3. Multifeder Tray Paper Width Detection PCB

- 1) Perform the steps on p. 3-19 to remove the multifeder tray.
- 2) While freeing the sub tray, disengage the two claws to detach the sub tray.

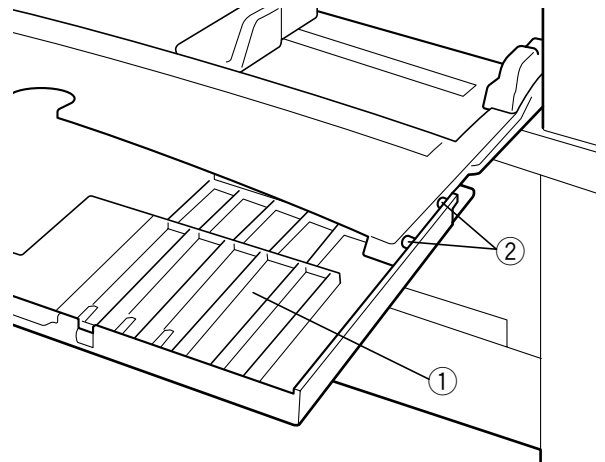

- ① Sub tray
- ② Claws

Figure 5-633

- 1) Open the multifeeder tray.
- 2) Remove the screw, and disconnect the connector; then, detach the multi-feeder tray paper width detection PCB.

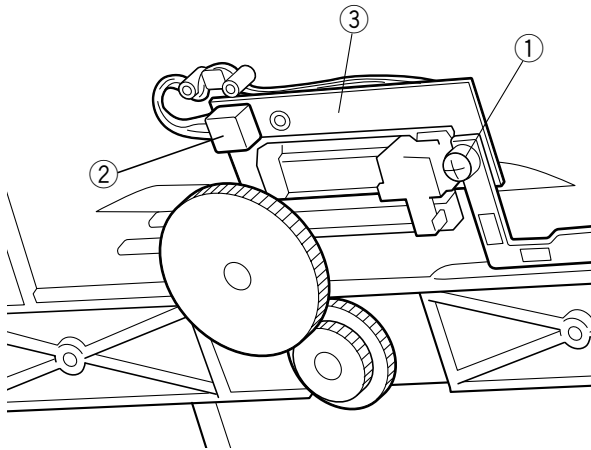

- ① Screw
- ② Connector
- ③ Multifeeder tray paper width detection PCB

Figure 5-634

CHAPTER 6

FIXING SYSTEM

This chapter provides descriptions on the machine's fixing operations, functions of each operation, relationships between electrical and mechanical systems, and timing at which each associated part is turned on.

I.	OUTLINE.....	6-1	D.	Detecting a Fault in the Fixing Assembly.....	6-4	
II.	FIXING CONTROL CIRCUIT.....	6-2	III.	DISASSEMBLY/ASSEMBLY	6-9	
	A.	Controlling the Fixing Temperature	6-2	A.	Fixing Assembly	6-10
	B.	Preventing Rush Current	6-3			
	C.	Protecting the Fixing Assembly	6-4			

I. OUTLINE

The upper fixing roller, lower roller, and fixing delivery roller are driven by the main motor (M4).

Paper separated from the intermediate transfer drum is fed inside the fixing assembly, moved between upper and lower fixing rollers and past the fixing delivery roller to the outside of the fixing assembly.

Paper coming out of the fixing assembly is detected by the fixing delivery sensor (PS1903).

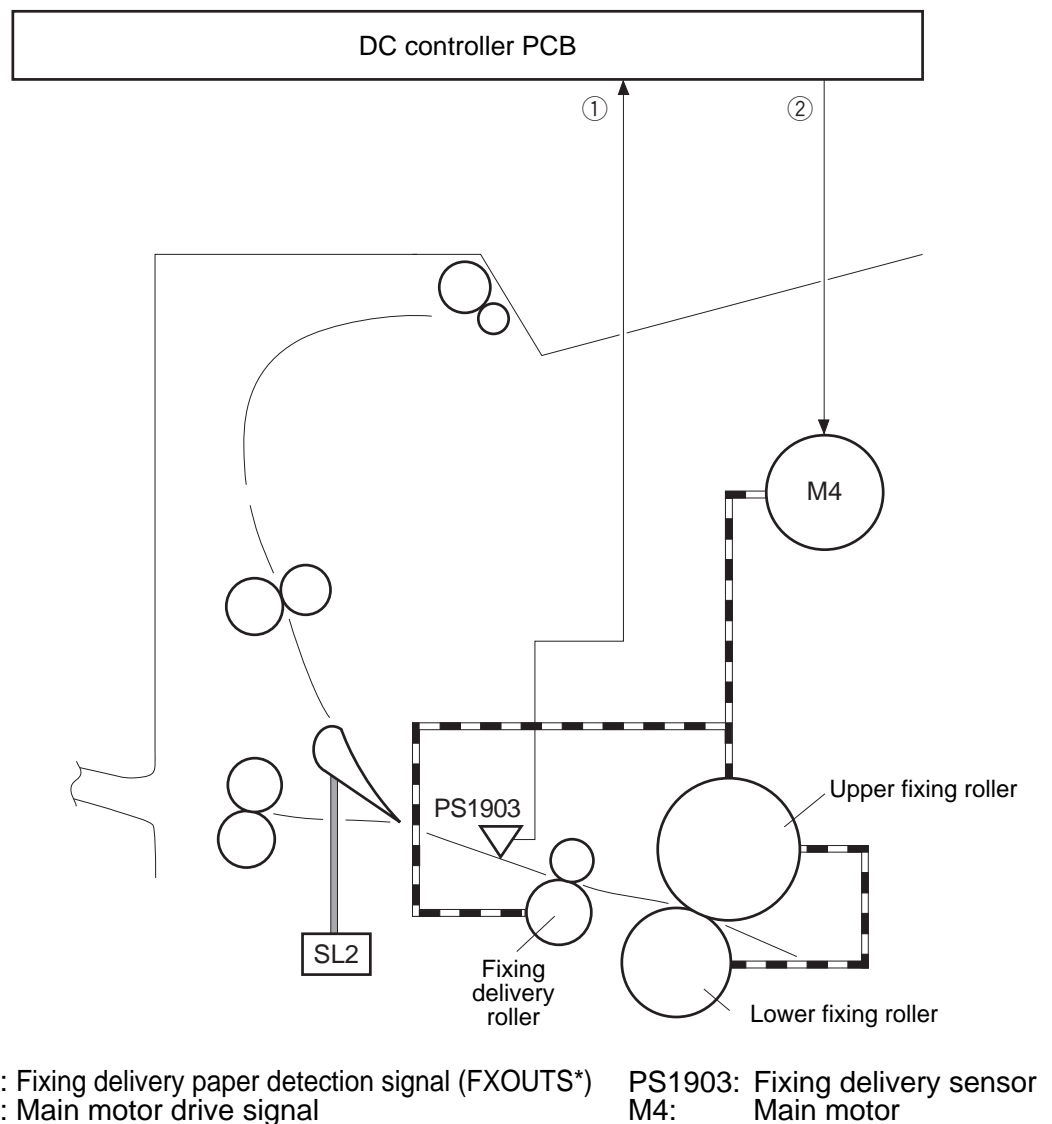

Figure 6-101

II. FIXING CONTROL CIRCUIT

A. Controlling the Fixing Temperature

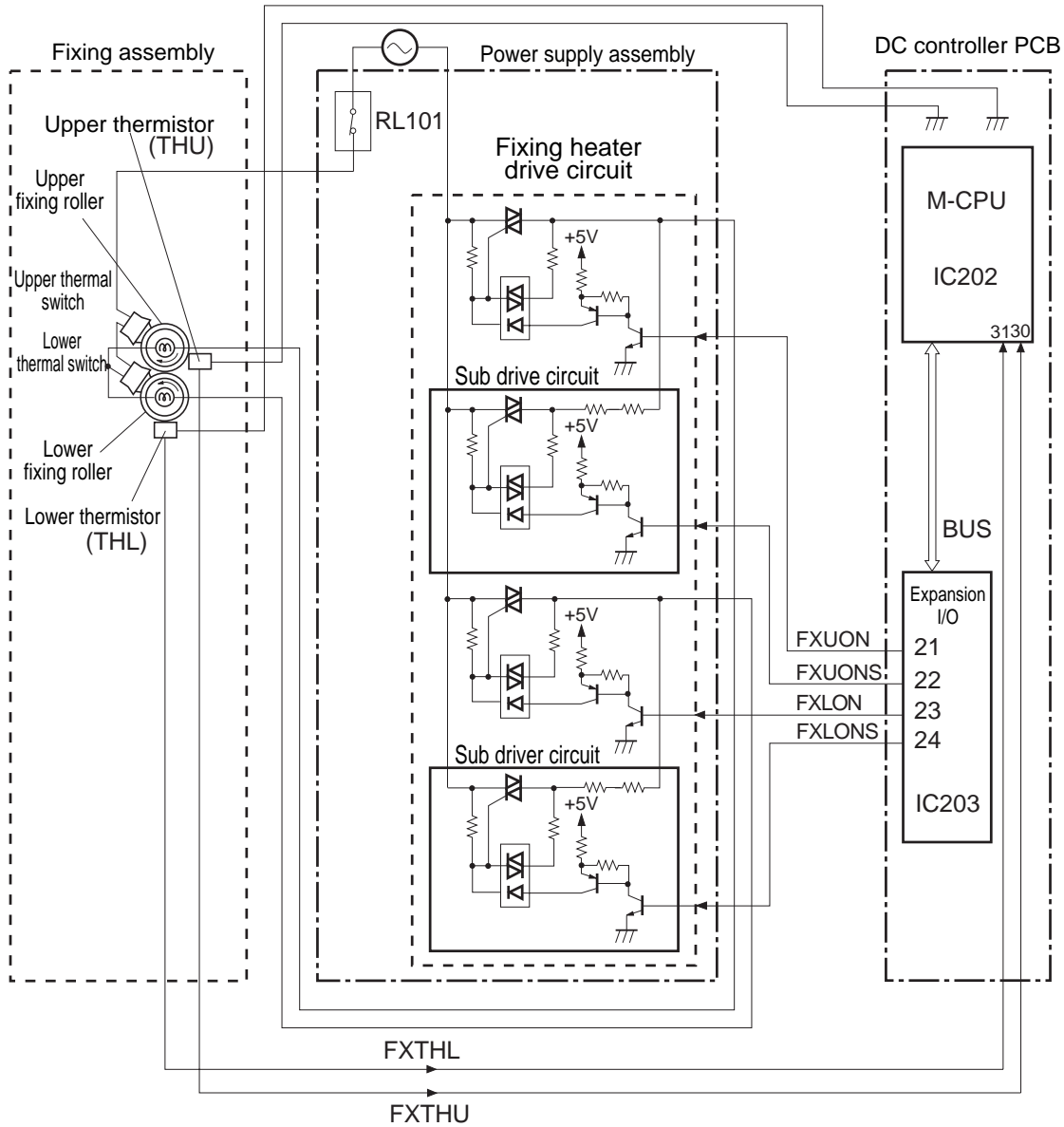

Figure 6-201

The fixing temperature is monitored by the upper thermistor (THU) mounted on the upper fixing roller and the lower thermistor (THL) mounted on the lower fixing roller.

When the surface temperature of the upper fixing roller and the lower fixing roller increases, the resistance of THU and THL will decrease, gradually lowering the voltage of the fixing temperature detection signal (FXTHU, FXTHL) sent to the M-CPU (IC202) on the DC controller PCB.

The M-CPU on the DC controller PCB controls the fixing heater drive signal (FXUON, FXLON) according to the voltage of the FXTHU and FXTHL signals and through the expansion I/O (IC203) so that the fixing temperature remains a specific value.

- During standby, the temperature is controlled to 165°C.
- During printing, the temperature is varied to suit the selected fixing mode (Note).

Reference:

The voltage is highest in the reader unit while the scanner is moved in reverse during printing operation with the reader unit installed. As such, the fixing heater is turned off.

Note:**Fixing Mode**

The printer unit sets the target temperature for the upper/lower fixing roller as follows according to the mode communicated by the printer board*1:

Target temperature	Color mode	Fixing mode				
		Plain paper mode	Transparency mode	Thick paper mode	Envelope mode	Special fixing mode
	Full-color	180°C	175°C	175°C	185°C	180°C
	Mono-color	180°C	175°C	175°C	185°C	180°C

Table 6-201

*1 Reader controller PCB (when making prints with the reader unit installed).

B. Preventing Rush Current

The printer unit uses two heaters, and rush current would be appreciative if both heaters were turned on at the same time.

In the light of this, the printer unit uses the expansion I/O (IC203) at time of power-on to generate the rush current prevention drive signal (FXUONS) for the upper fixing heater and the rush current prevention drive signal (FXLONS) for the lower fixing heater to turn on the sub drive circuit for a specific period of time to suppress the current applied to the heaters.

C. Protecting the Fixing Assembly

The printer unit is equipped with the following three types of protective mechanisms to prevent malfunction of the fixing heater:

- The M-CPU monitors the voltage of the upper fixing roller temperature detection signal (FXTHU) and the lower fixing roller temperature detection signal (FXTHL). If either or both incur an error, the M-CPU will identify the condition as a fixing heater fault, and will communicate the fact to the printer board*1 to cut off the power to the heaters.
- If the fixing temperature increases abnormally and, as a result, either or both upper and lower thermistor (THU, THL) readings exceed about 230°C, the safety circuit will cut off the power to the heaters regardless of the output of the M-CPU. At the same time, the M-CPU identifies the condition as a power supply fault, and communicates the fact to the printer board¹ by way of the D-CPU.
- If the fixing temperature increases abnormally and, as a result, the temperature of either or both upper and lower thermal switch exceeds about 240°C, the upper/lower thermal switch will turn off to cut off the power to the fixing heaters.

*1 Reader controller PCB (when making prints with the reader unit installed).

Note:

To reset the printer unit after a fixing heater error has been stored in the error memory capacitor (C259), turn it off and then on after leaving it alone for 30 min or more.

D. Detecting a Fault in the Fixing Assembly

A fault in the fixing assembly is checked by the following three:

1. M-CPU on the DC controller PCB
 2. Fixing heater safety circuit (in the power supply circuit)
 3. Fixing assembly error detection circuit (in the power supply circuit)
- Details follow.

1. M-PCU on the DC Controller PCB

If the fixing assembly is abnormally heated or it fails to reach a specific temperature, the M-CUP uses the D-CPU to stop the operation of the fixing heater, and cut the relay (RL101) to shut off the power to the fixing heater.

The DC controller then communicates the fault in the fixing heater to the printer board*1.

Specifically, the M-PCU detects a fault in the fixing heater under any of the following conditions:

- a. A fixing assembly error is stored in the error memory capacitor (C259) on the DC controller PCB at time of power-on. (error low temperature E003 or error high temperature E001)
- b. The increases in temperature are monitored every 20°C from 20°C to when the standby temperature is attained after the fixing heater is driven; the time required is compared against the reference time, and the time required is longer than the reference time.
- c. The fixing assembly temperature drops below 120°C after it has reached the target level. (error low temperature E003)
- d. The fixing temperature reaches about 230°C or more during standby or during copying. (error high temperature E001; Note 1)

- e. The sensitivity of the thermistor (Note 2) is on the high temperature side at power-on (during initial state), but the upper and lower fixing roller detection signals (FXTHU, FXTHL) are 60°C or less. The thermistor sensitivity is switched from the high to the lower temperature side.

At this time, either FXTHU or FXTHL is -10°C or less. (thermistor open circuit)

However, if both FXTHU and FXTHL are -10°C or less, the absence of the fixing assembly will be indicated (E813).

Caution:

1. If an error high or low temperature is detected, the M-CPU uses the D-CPU to store a fixing heater error in the error memory capacitor (C259).
Once this happens, turn off the power once, leave the printer unit alone for 30 min or more, and turn on the power once again to reset the printer unit.
2. Switching the Thermistor Sensitivity
The machine's M-PCU switches the thermistor sensitivity (between low-temperature sensitive mode and high-temperature sensitive mode) to ensure accurate detection regardless of the range of temperature (low or high) using the thermistor sensitivity switch signal (FXSEL). When the FXSEL signal is '0', the thermistor will be in low-temperature detection mode; when '1', high-temperature detection mode.

2. Fixing Heater Safety Circuit (on the power supply circuit; E808)

The fixing heater safety circuit is found in the power supply assembly, and serves to check the upper and lower fixing heaters for a fault.

- a. When the fixing heater safety circuit finds a fault in the upper fixing heater, If the fixing temperature increases abnormally, the power from the power supply assembly to the upper/lower heater will be cut off.

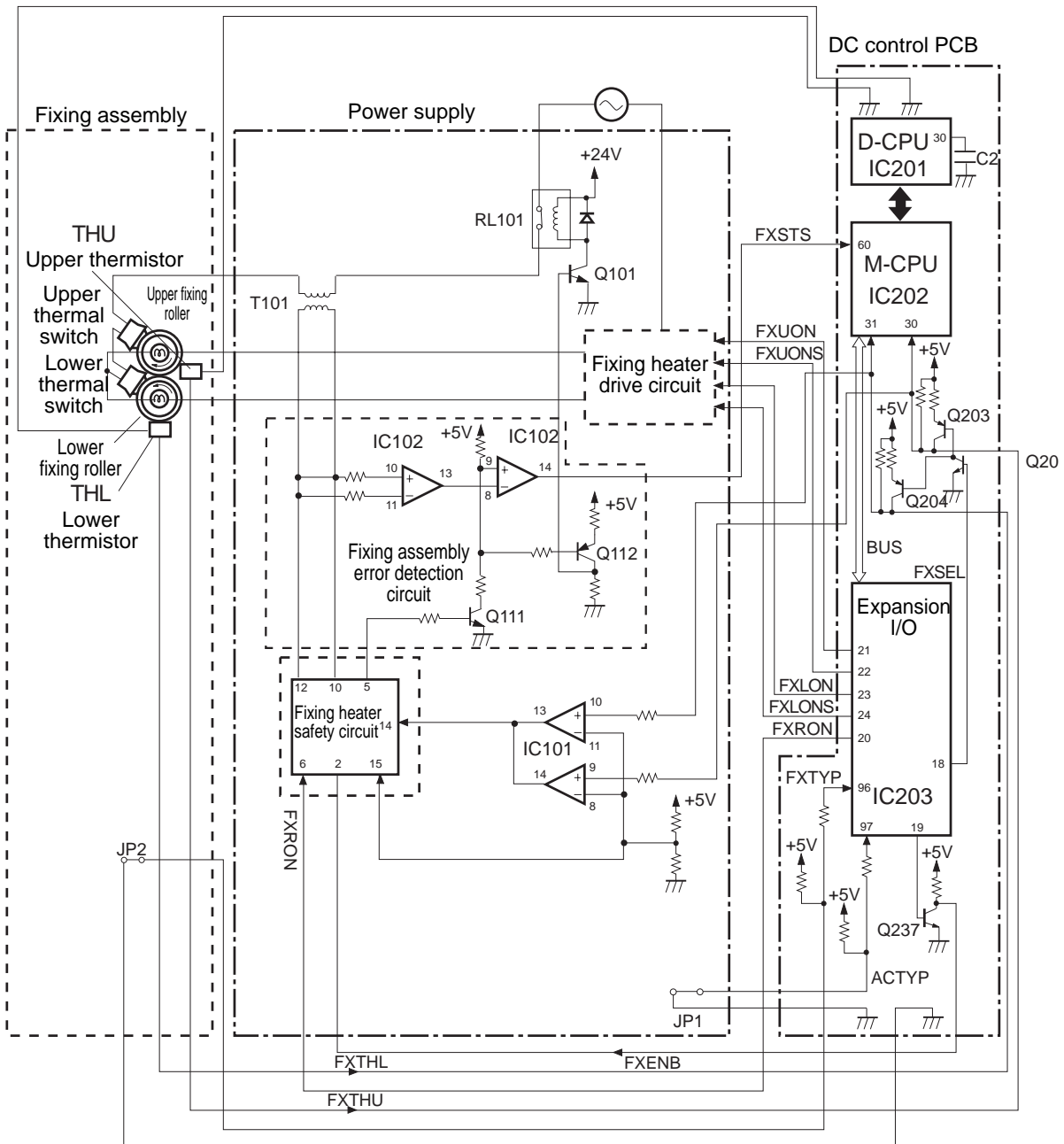

Figure 6-202

See Figure 6-202 and the following text for the functions of the circuit:

The fixing heater safety circuit in the power supply monitors the upper fixing roller temperature detection signal (FXTHU) at pin No. 14. When increases in the fixing temperature causes the output voltage of the upper thermistor to be about 1.4 V, the output of pin No. 13 of IC101 goes '1', and the signal at pin No. 14 of the fixing heater safety circuit will be '1'. In response, the fixing heater safety circuit causes the output of pin No. 5 to go '0'.

Then, Q111 of the fixing assembly error detection circuit turns off to turn off Q112 and thereby to turn off the relay (RL101), cutting off the power to the upper fixing heater and the lower fixing heater.

b. If the fixing heater safety circuit finds a fault in the lower fixing heater,

The fixing heater safety circuit is in the power supply and, if an abnormal increase occurs in the fixing temperature, it cuts off the power to the upper and lower fixing heaters.

See Figure 6-202 and the following text for the functions of the circuit:

The fixing heater safety circuit in the power supply monitors the lower fixing roller temperature detection signal (FXTHL) at pin No. 14. When increases in the fixing temperature causes the output voltage of the upper thermistor to be about 1.4 V, the output of pin No. 9 of IC101 goes '1', and the signal at pin No. 14 of the fixing heater safety circuit will be '1'. In response, the fixing heater safety circuit causes the output of pin No. 5 to go '0'.

Then, Q111 of the fixing assembly error detection circuit turns off to turn off Q112 and thereby to turn off the relay (RL101), cutting off the power to the upper fixing heater and the lower fixing heater.

3. Fixing Assembly Error Detection Circuit (in the power supply circuit)

This circuit is in the power supply, and monitors the fixing assembly for an open condition of the thermal switch and the fixing heater for an open circuit.

a. Displaced Fixing Assembly (E009)

The fixing assembly error detection circuit checks to find out whether the rated voltage of the power supply and the rated voltage of the fixing assembly match. For instance, if a 100-V power supply and a 220V fixing assembly are connected, it will identify a rated voltage mismatch. If the fixing assembly is not mounted, the expansion I/O (IC203) on the DC controller PCB will assume a fixing assembly type mismatch, and communicates the fact to the printer board*1 to stop the operation of the printer unit.

The rated voltage of the power supply is set by means of a jumper wire (JP1; for a 100V power supply, JP1 is open, while JP1 is shorted for a 200V power supply). The setting is monitored by the expansion I/O using the power supply type detection signal (ACTYP).

The rated voltage of the fixing assembly, on the other hand, is set by means of a jumper wire (JP2) inside the fixing assembly (for a 100-V fixing assembly, JP2 is open, while it is shorted for a 200-V model). The setting is monitored by the expansion I/O as the fixing assembly type detection signal (FXTYP).

If the rated voltage of the power supply and the rated voltage of the fixing assembly do not match, the expansion I/O will identify the condition as displacement of the fixing assembly.

b. Open Circuit in the Fixing Heater (E004)

At the start of temperature control, the printer unit drives the upper fixing heater and the lower fixing heater, one at a time to check the FXSTS signal for an open circuit in the fixing heaters.

The fixing assembly error detection circuit detects AC current flowing through the fixing heater. If AC current is absent, the M-CPU on the DC controller PCB will assume the condition as an open circuit in the fixing heater, stopping the drive to the fixing heater and communicating the fact to the printer board*1 as a fault in the fixing assembly.

The AC current to the upper/lower fixing heater is checked in reference to the voltage induced at T101. The voltage occurring at T101 is monitored by pin No. 10 of IC102. If the upper/lower fixing heater has an open circuit or if the upper thermal switch opens, AC current stops flowing and the output of pin No. 13 of IC102 goes '1'. As a result, the output of pin No. 14 of IC102 will be '1', and the fixing heater status detection signal (FXSTS) will go '0'.

If AC current is flowing, on the other hand, the FXSTS signal alternates between '1' and '0' at specific intervals, allowing the M-CPU to use the FXSTS signal to detect an open circuit in the fixing heater.

*1 Reader controller PCB (when making prints with the reader unit installed).

III. DISASSEMBLY/ASSEMBLY

Make sure of the following when disassembling or assembling the machine:

1. **⚠** When the printer unit power switch is turned off, the fans will operate for about 30 min to cool the machine (so as to prevent caking of toner). Be sure to perform either of the following in addition to disconnecting the power plug:
 - Wait for 30 min after turning off the printer unit power switch; or
 - Turn off the printer unit power switch, and remove the fixing assembly of the printer unit.
2. Assemble the parts by reversing the steps used to disassemble them, unless otherwise mentioned.
3. Identify the screws by type (length, diameter) and location.
4. Do not leave out the toothed washer that comes with one of the mounting screws on the rear cover to protect against static electricity.
5. Do not leave out the washer that comes with the screw used for the grounding wire and the varistor to ensure electrical continuity.
6. Do not operate the machine with any of its parts removed, unless otherwise mentioned.
7. **⚠** Do not throw a toner cartridge into fire. It may explode.
8. Keep any toner cartridge in a protective cover whenever it has been taken out of the printer unit for disassembly/assembly work even for a short time.
9. Remove the cartridge and the intermediate transfer drum before disassembly/assembly work or moving the machine.
10. Touch the copier's metal section before starting the work to discharge the build-up of static electricity so as to prevent static damage before handling any PCBs.
11. To slide out the printer unit from the rack (if the reader unit is also mounted to the rack), pull halfway out the two side pins at the bottom of the rack (middle pin orientation *), and then remove the printer unit fixing member from the left of the printer unit. Be sure also to remove the printer side power cord and the interface cable.

For removal of the external covers of the printer unit, see IV.A. "External Covers of the Printer Unit" in Chapter 3.

A. Fixing Assembly

1. Construction

The fixing assembly serves to fuse toner into the fibers of paper, and constructed as shown in Figure 6-301 (cross sectional view).

- ① Fixing assembly locking lever
- ② Upper thermistor
- ③ Upper fixing roller
- ④ Upper fixing heater
- ⑤ Upper thermal switch
- ⑥ Fixing assembly inlet guide
- ⑦ Lower fixing heater
- ⑧ Lower fixing heater
- ⑨ Lower thermistor
- ⑩ Lower thermal switch
- ⑪ Fixing assembly releasing lever
- ⑫ Lower separation guide
- ⑬ Upper separation guide

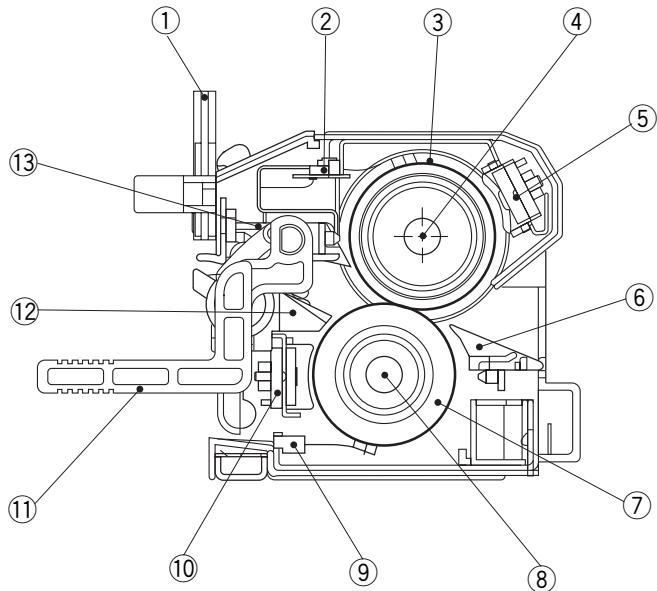

Figure 6-301

2. Removing the Fixing Assembly

Caution:

If the duplexing unit is mounted, be sure to remove it before removing the fixing assembly.

- 1) Open the delivery cover.
- 2) Shift the two fixing assembly locking levers and the releasing lever in the direction of the arrows; then, lift the fixing assembly slightly, and detach it to the front.

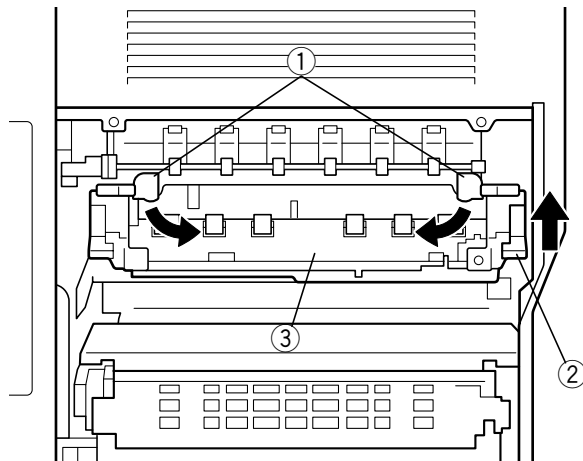

- ① Fixing assembly locking lever
- ② Releasing lever
- ③ Fixing assembly

Figure 6-302

3. Mounting a New Fixing Assembly

- 1) Prepare a new fixing assembly, and detach the two spacers (orange).

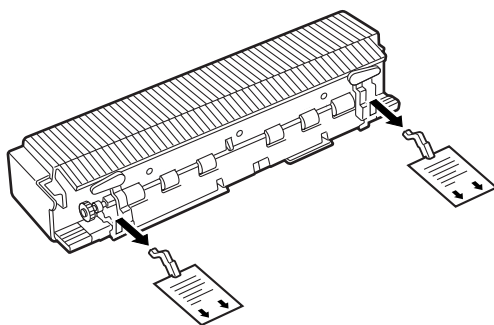

Figure 6-303

- 2) Place the fixing assembly on the guide as shown.

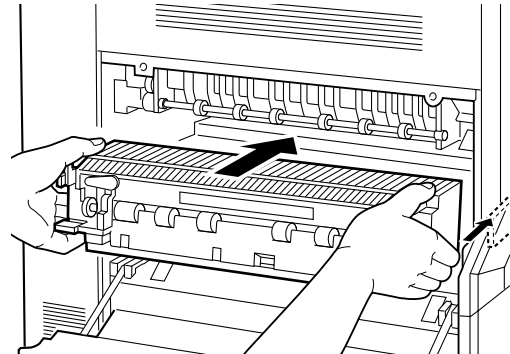

Figure 6-304

- 3) Push the fixing assembly until it butts against the rear end of the printer unit.

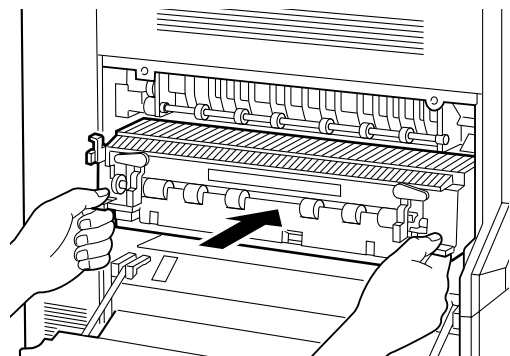

Figure 6-305

- 4) Push down the fixing assembly 1 to place it correctly. Then, shift up the levers 2 to secure it in place.

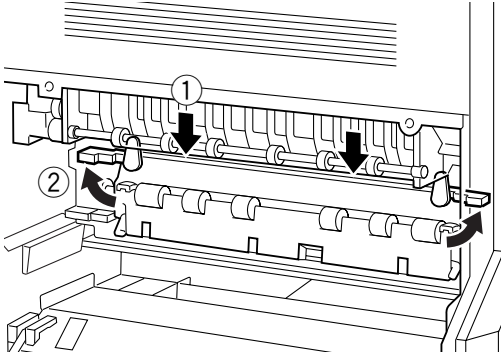
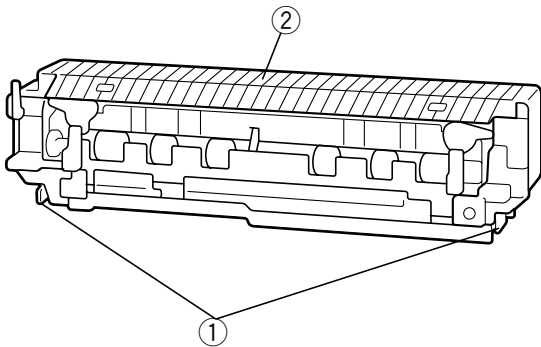

Figure 6-306

- 5) If you removed the duplexing unit, mount it.
- 6) Close the lower left cover.

4. Removing the Upper Thermal Switch

- 1) Disengage the two claws, and remove the fixing cover 1.



- ① Claws
- ② Fixing cover 1

Figure 6-307

- 2) Remove the three screws, and detach the upper thermal switch.

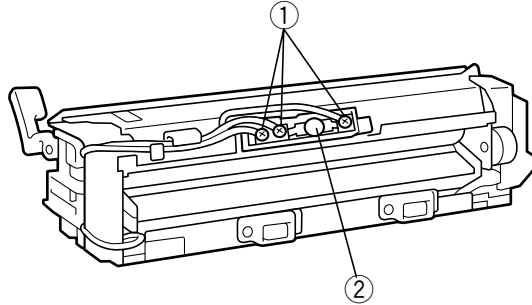

- ① Screws
- ② Thermal switch

Figure 6-308

5. Removing the Upper Thermistor

- 1) Perform step 1) on p. 6-12 to remove the fixing cover 1.
- 2) Remove the two screws, and detach the fixing cover 2.

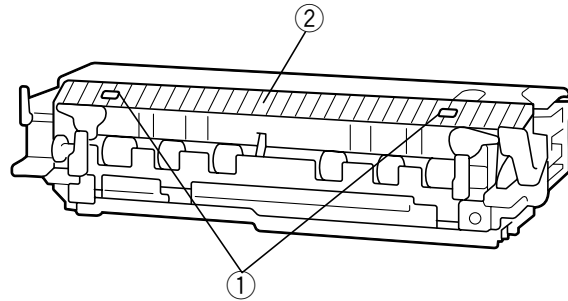

- ① Screws
- ② Fixing cover 2

Figure 6-309

- 3) While pushing the claws with a high-accuracy screwdriver, pull up the fixing assembly inlet guide to the front to detach.

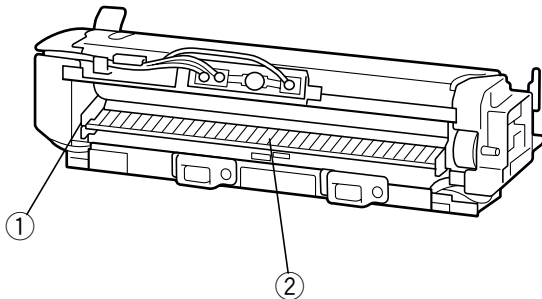

- ① Claw
- ② Fixing assembly inlet guide

Figure 6-310

- 4) Disconnect the connector (white).

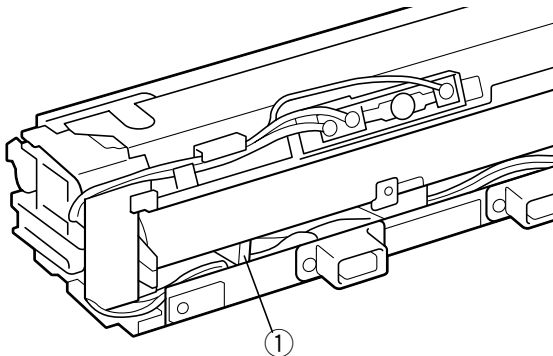

- ① Connector

Figure 6-311

- 5) Remove the screw, and detach the upper thermistor.

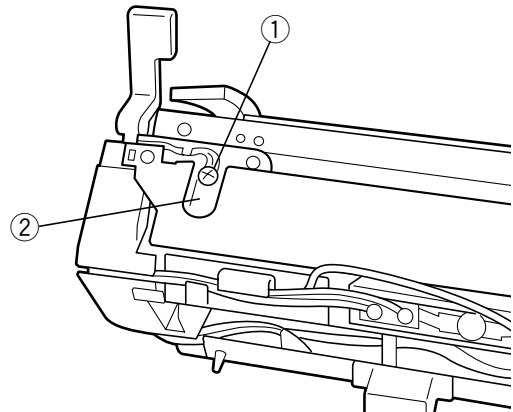

- ① Screw
- ② Upper thermistor

Figure 6-312

6. Removing the Lower Thermal Switch

- 1) Shift down the jam removal lever, and remove the E-shaped stop ring and the spring; then, slide the lower separation guide in the direction of the arrow to detach it from the lower separation guide.

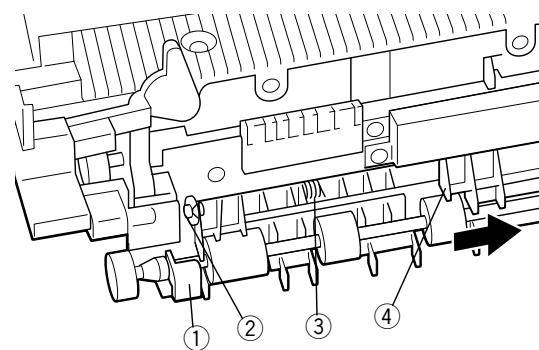

- ① Jam removal lever
- ② E-shaped stop ring
- ③ Spring
- ④ Lower separation guide

Figure 6-313

- 2) Remove the two screws, and detach the thermal switch cover.

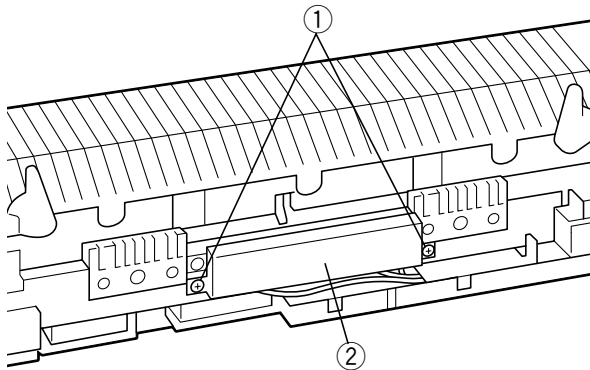

- ① Screws
- ② Thermal switch cover

Figure 6-314

- 3) Remove the three screws, and detach the lower thermal switch.

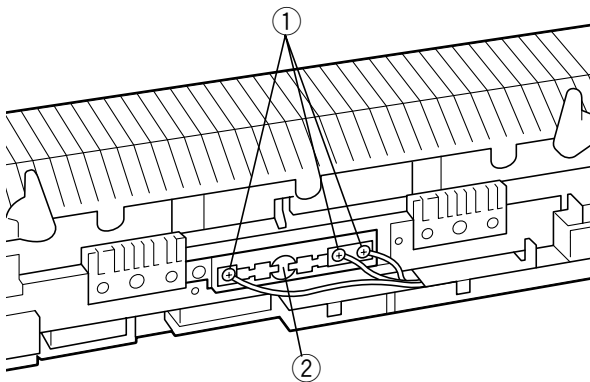

- ① Screws
- ② Lower thermal switch

Figure 6-315

7. Removing the Lower Thermal Switch

- 1) Perform steps 1) through 6) on p. 6-17 to remove the fixing assembly right cover.
- 2) Disconnect the connector (lack).

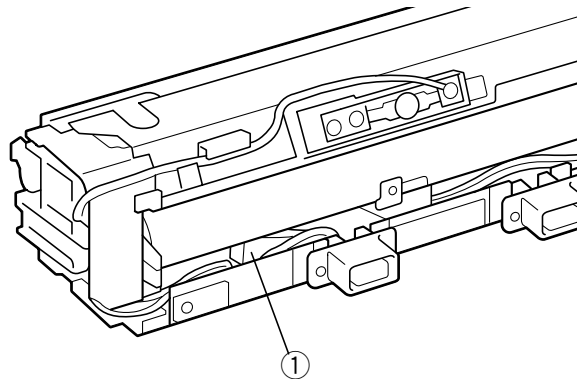

- ① Connector

Figure 6-316

- 3) Disengage the three claws, and disconnect the connector cover.

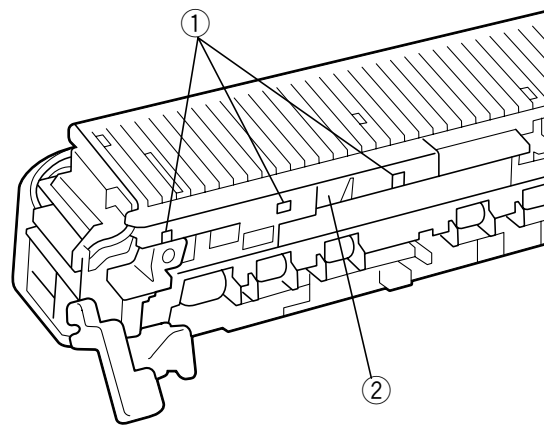

- ① Claws
- ② Connector cover

Figure 6-317

- 4) Slide the fixing assembly lower cover to the right to detach.

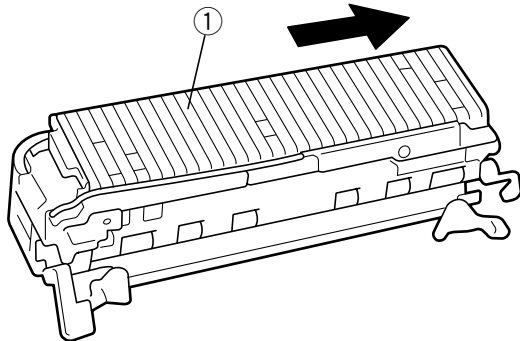

① Lower cover

Figure 6-318

- 5) Remove the screw, and detach the lower thermistor.

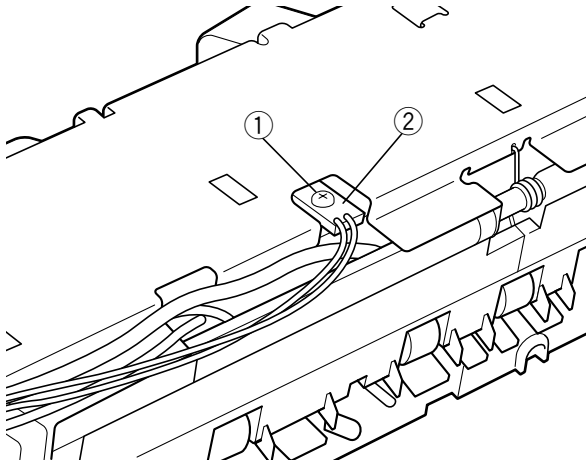

① Screw ② Lower thermistor

Figure 6-319

8. Removing the Upper Fixing Heater

- 1) Perform steps 1) on p. 6-12 to remove the fixing cover 1.
- 2) Remove the screw, and detach the lead wire.

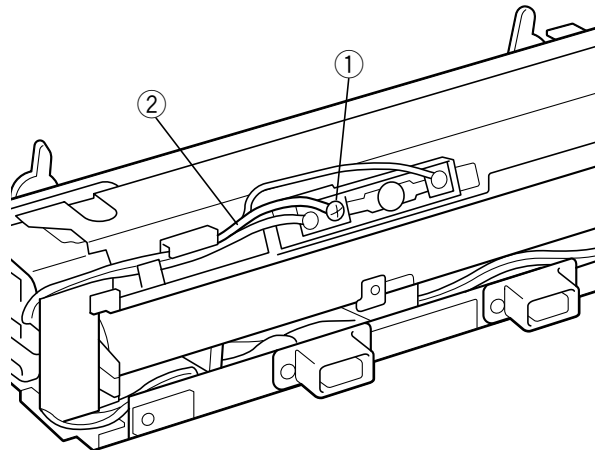

① Screw ② Lead wire

Figure 6-320

- 3) Using the contact extracting tool (RY9-0099), remove the heater contact from inside the connector.

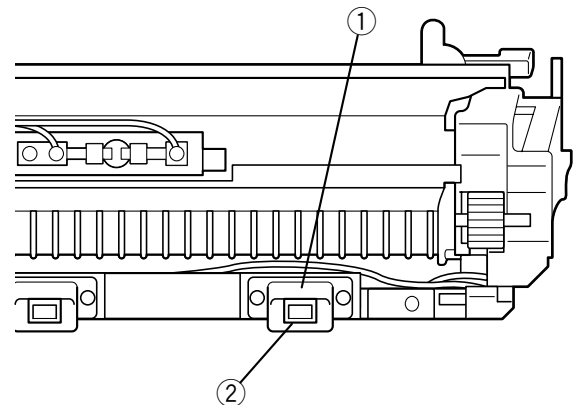

① Connector ② Heater contact

Figure 6-321

- 4) Remove the two screws, and pull out the connector; then, pull out the lead wire.

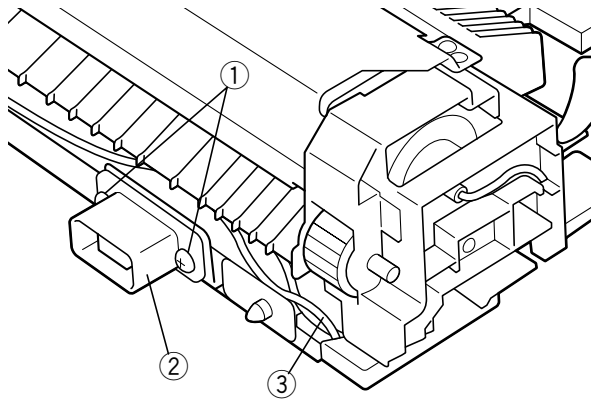

- ① Screws ② Connector
③ Lead wire

Figure 6-322

- 5) Remove the screw, and remove the heater metal fixing; then, pull out the upper heater slowly.

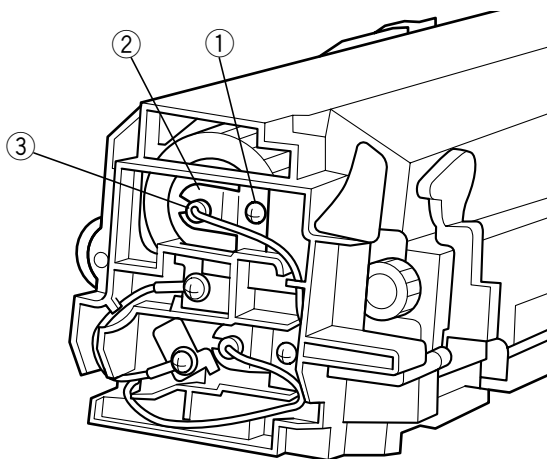

- ① Screw ② Heater metal fixing
③ Upper heater

Figure 6-323

9. Removing the Lower Fixing Heater

- 1) Perform step 1 on p. 6-12 to remove the fixing cover 1.
2) Remove the screw, and detach the lead wire.

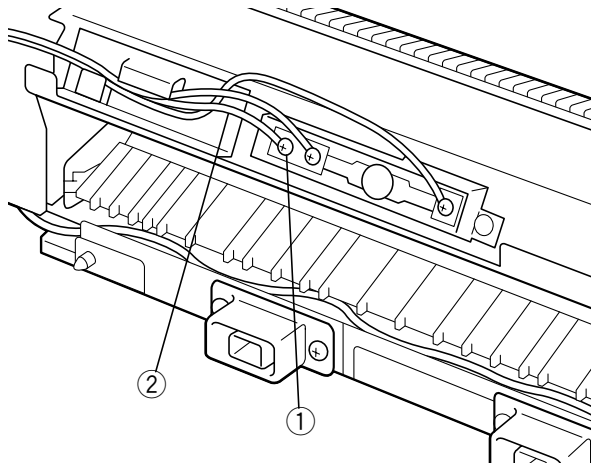

- ① Screw ② Lead wire

Figure 6-324

- 3) Using the contact extracting tool (RY9-0099), pull out the heater contact from inside the connector.

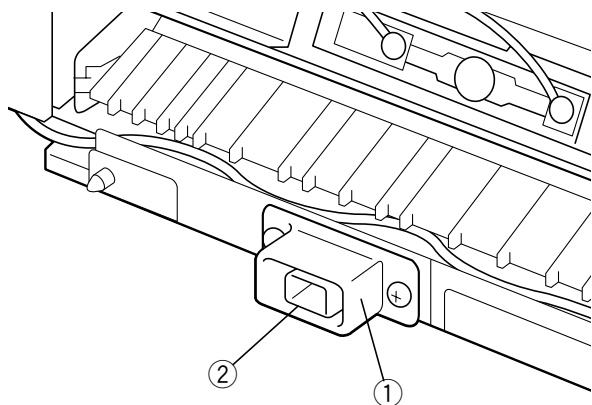

- ① Connector ② Heater contact

Figure 6-325

- 4) Remove the two screws, and pull out the connector; then, pull out the lead wire.

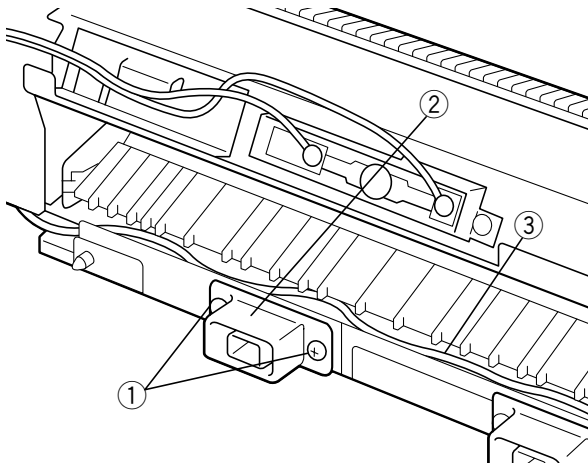

- ① Screw ② Connector
③ Lead wire

Figure 6-326

- 5) Remove the screw, and remove the heater metal fixing; then, pull out the lower heater slowly.

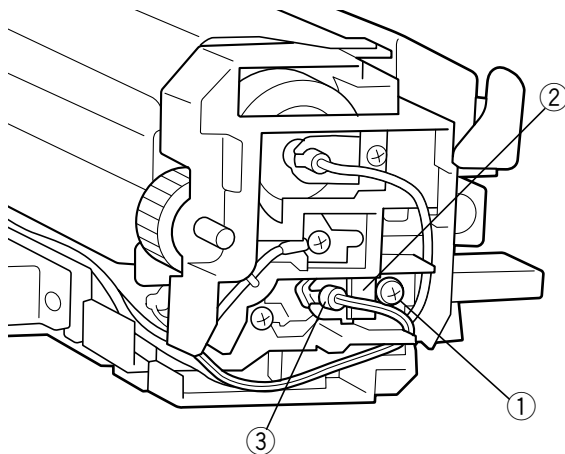

- ① Screw ② Heater metal fixing
③ Lower heater

Figure 6-327

Points to Note When Mounting

When securing the lead wire terminal of the fixing heater or the like with a screw, take care not to subject the lead wire to excess force.

10. Removing the Upper Fixing Roller

- 1) Perform the steps on p. 6-1 to remove the upper fixing heater.
- 2) Perform steps 2) through 5) on p. 6-12 to remove the upper thermistor.
- 3) Perform steps 2) through 5) on p. 6-16 to remove the lower fixing heater.
- 4) Pull up the releasing lever to remove; then, slide the releasing lever in the direction of the arrow to detach.

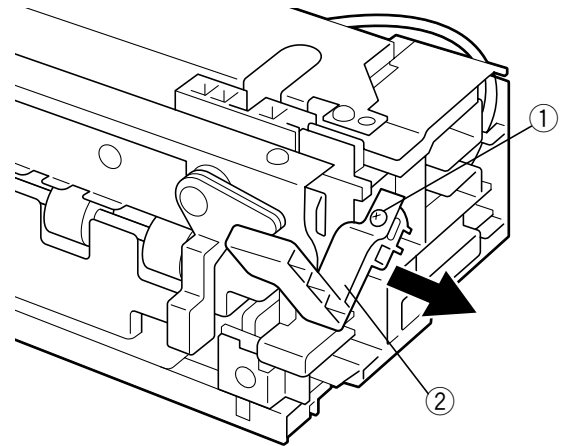

- ① Screw ② Releasing lever

Figure 6-328

- 5) Remove the two screws, and detach the two lead wires and the two contact plates.

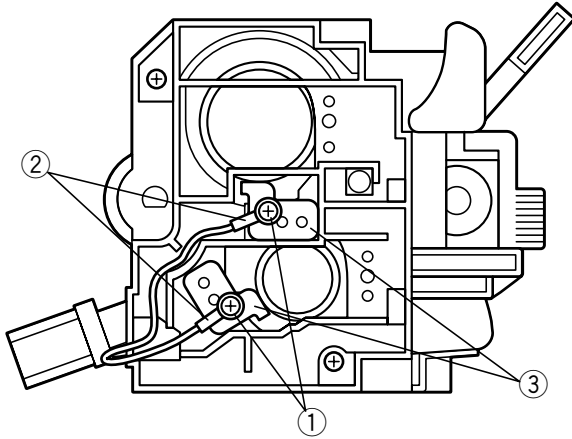

- ① Screws ② Lead wires
③ Contact plates

Figure 6-329

- 7) Remove the grounding ring; then, remove the C-shaped stop ring.

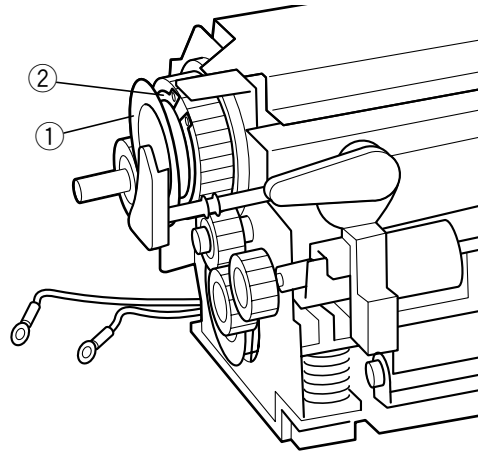

- ① Grounding ring
② C-shaped stop ring

Figure 6-331

- 6) Remove the two screws, and detach the fixing assembly right cover.

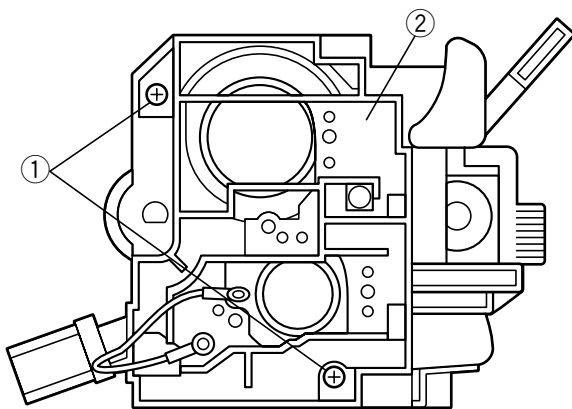

- ① Screws
② Fixing assembly right cover

Figure 6-330

- 8) Remove the gear; then, remove the bushing and the bearing.

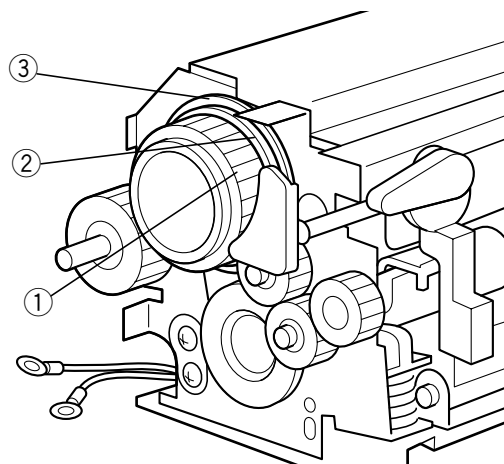

- ① Gear ② Bushing
③ Bearing

Figure 6-332

9) Remove the screw, and detach the thermal holder together with the upper thermal switch.

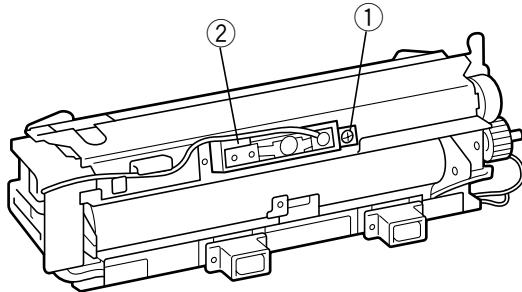

- ① Screw
- ② Thermal holder

Figure 6-333

10) Remove the two screws, and detach the fixing assembly left cover.

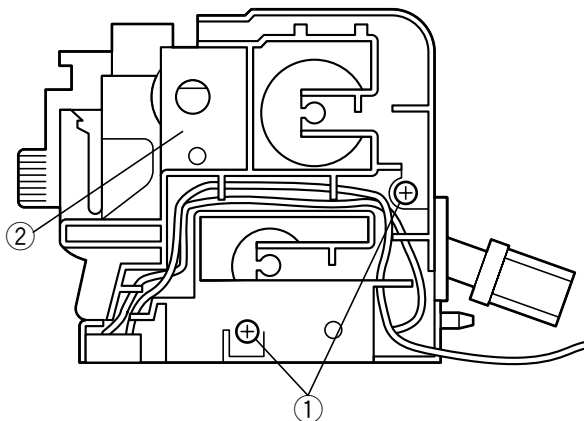

- ① Screws
- ② Fixing assembly left cover

Figure 6-334

11) Remove the two screws, and detach the fixing assembly upper safety.

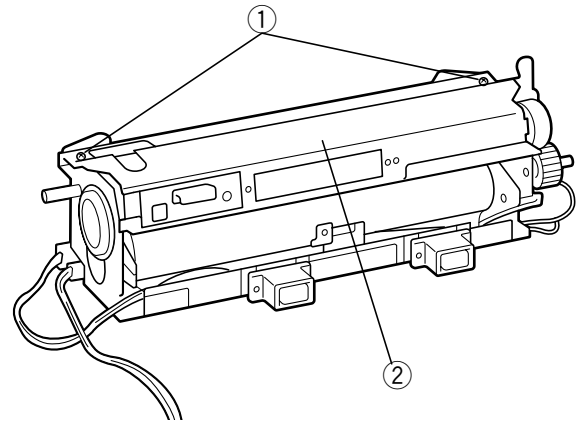

- ① Screws
- ② Fixing assembly upper stay

Figure 6-335

12) Remove the C-shaped stop ring, and remove the bushing and bearing; then, detach the fixing assembly roller.

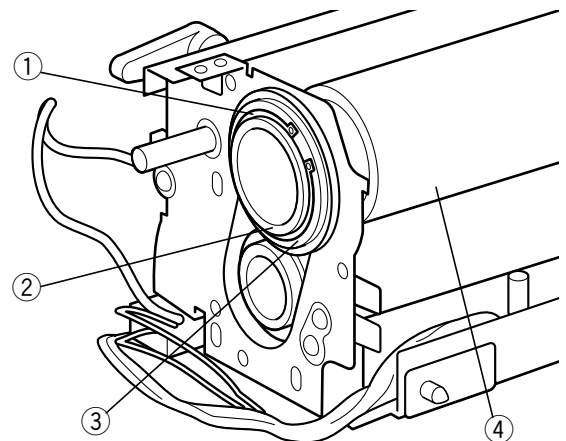

- ① C-shaped stop ring
- ② Bushing
- ③ Bearing
- ④ Fixing assembly upper roller

Figure 6-336

11. Removing the Fixing Assembly Lower Roller

- 1) Perform the steps on p. 6-17 to remove the upper fixing roller.
- 2) Remove the C-shaped stop ring, and remove the bushing and the bearing.

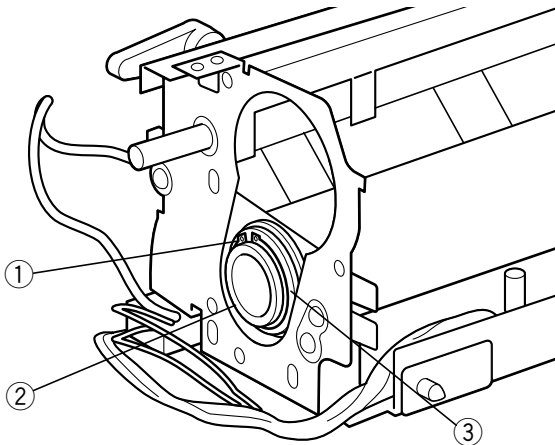

- ① C-shaped stop ring
- ② Bushing
- ③ Bearing

Figure 6-337

- 3) Remove the grounding ring, and remove the C-shaped stop ring.

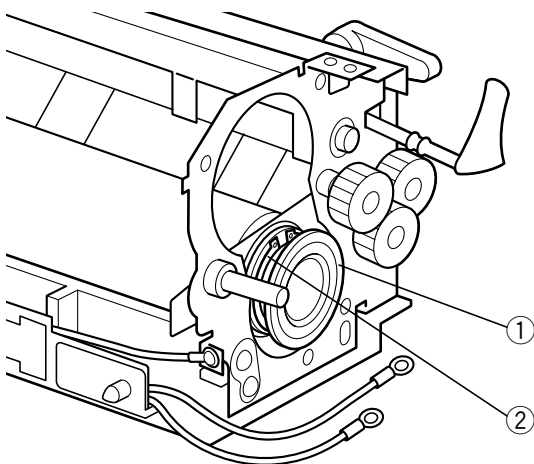

- ① Grounding ring
- ② C-shaped stop ring

Figure 6-338

- 4) Remove the bushing and the bearing.

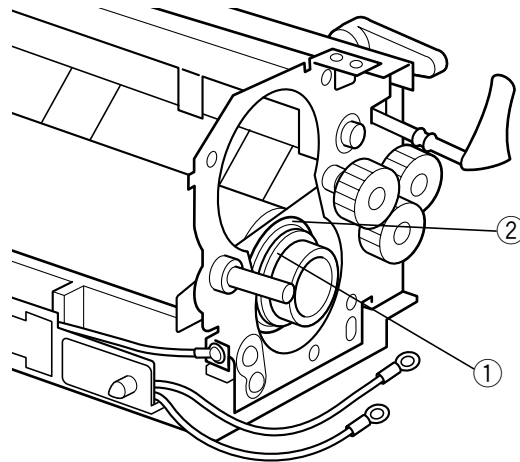

- ① Bushing
- ② Bearing

Figure 6-339

- 5) Remove the two screws, and detach the two upper separation guides; then, detach the lower fixing roller.

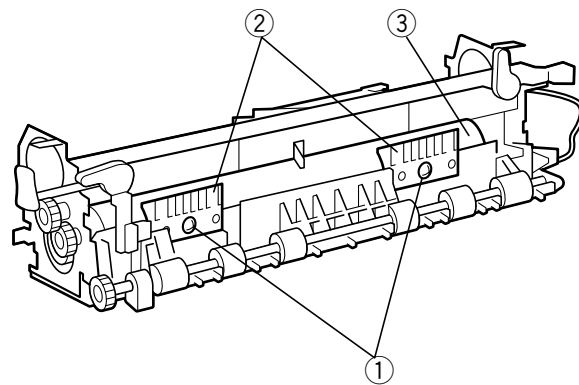

- ① Screws
- ② Upper separation guides
- ③ Lower fixing roller

Figure 6-340

CHAPTER 7

EXTERNALS/AUXILIARY MECHANISMS

This chapter provides descriptions on the machine's auxiliary control operations, functions of each operation, relationships between electrical and mechanical systems, and timing at which each associated part is turned on.

I.	CONTROL PANEL	7-1	B.	Remote Switch.....	7-6
	A. Outline.....	7-1	C.	Protective Mechanisms.....	7-7
	B. Operations.....	7-1	D.	Power Save Mode.....	7-8
II.	FANS.....	7-2	IV.	DISASSEMBLY/ASSEMBLY	7-9
III.	POWER SUPPLY	7-4	A.	Fans	7-10
	A. Power Supply	7-4	B.	Power Supply Assembly	7-13

I. CONTROL PANEL

A. Outline

The printer unit's control panel has ten LEDs, one LCD, eight switches, and one buzzer.

The control panel is connected to the printer board, and has the following functions:

- Using the LCD, indicates printer unit status and errors.
- Using the LEDs, indicates printer unit operations.
- In response to a switch input, selects a printing environment, operation mode, utility, and pick-up/delivery slot.
- In response to a faulty switch input, sounds the buzzer.

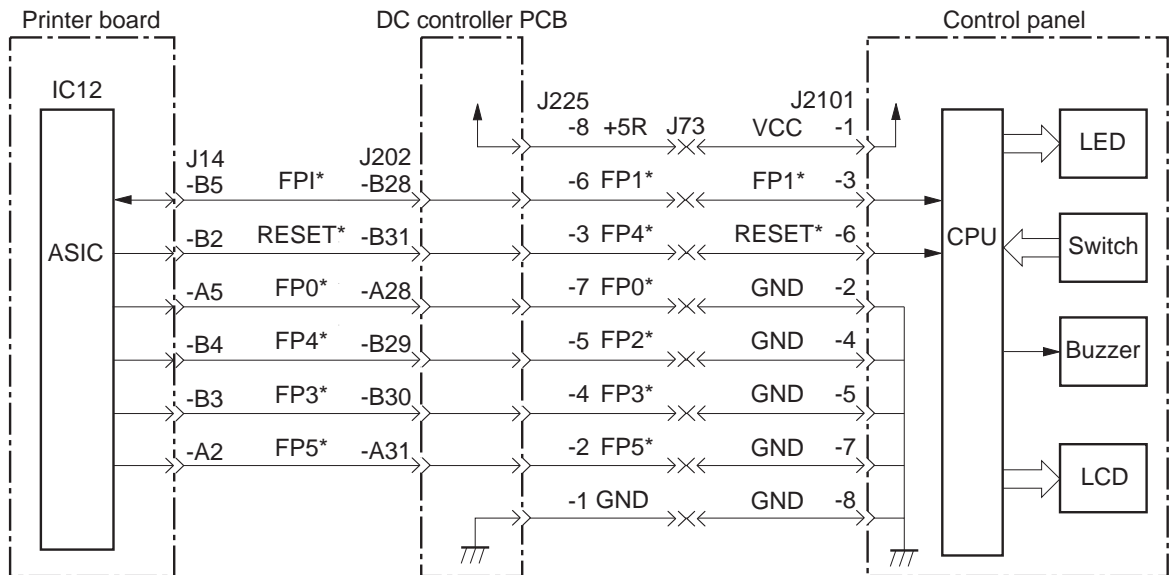

Figure 7-101

B. Operations

The control panel uses a single-line, dual-direction serial interface.

The ASIC on the printer board serves to exchange data between the control panel and the CPU. The data to the LEDs, LCD, and buzzer on the control panel and the various data occurring as a result of switch inputs are controlled by the FPI* signal (bi-directional data).

II. FANS

The printer unit is equipped with three fans to cool the inside and to discharge ozone.

Figure 7-101 shows the arrangement of the fans. Table 7-101 shows the functions of the fans, filters used by the fans, orientation of the fans, and error codes associated with the operation of the fans, while Figure 7-102 shows the timing at which each fan is turned on.

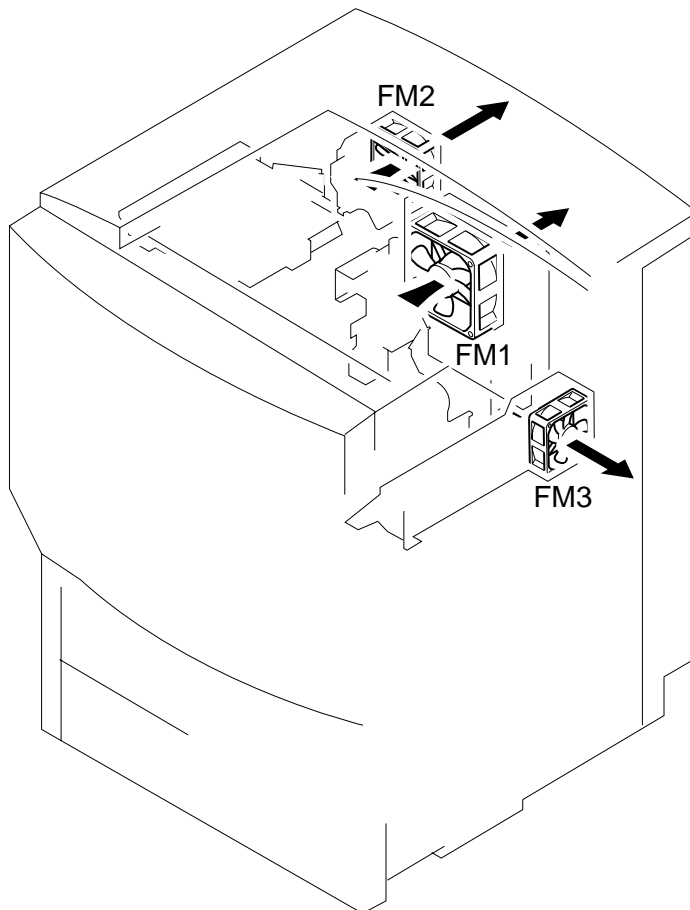

Figure 7-201

Notation	Name	Filter	Function	Error code
FM1	Heat discharge fan 1	Air	Discharges exhaust from around the fixing assembly and the feeding assembly.	E805
FM2	Heat discharge fan 2	Air	Discharges exhaust from around the intermediate transfer drum.	E806
FM3	Heat discharge fan 3	Ozone	Discharges heat from around the scanner	E807

Table 7-201

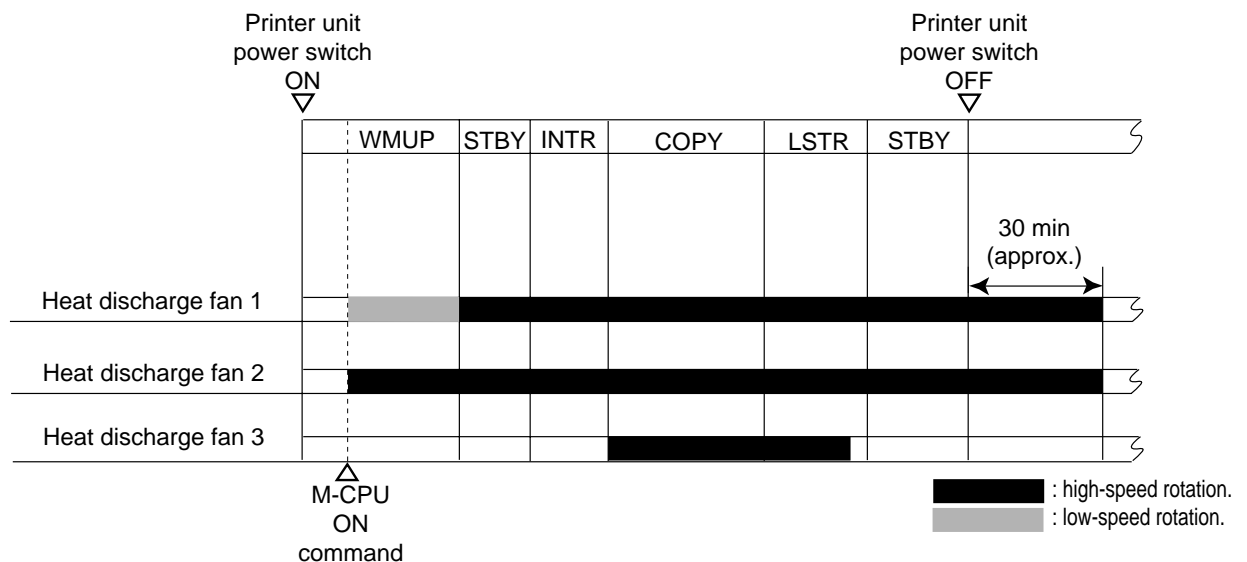

Figure 7-202

Note:

1. At the end of a printing run, the heat discharge fan 3 (FM3) stops once. However, the heat discharge fan 2 (FM2) will stop 30 min after the printer unit power switch is turned off to prevent increase in temperature inside the printer unit.
2. The heat discharge fan 1 (FM1) is equipped with a built-in thermistor used as part of the mechanism to vary the rotation speed of the fans to suit the machine internal temperature.

III. POWER SUPPLY

A. Power Supply

The low-voltage power supply circuit in the power supply generates +24 VB and +5 V DC power needed by the printer unit.

+24 VB is used as it is as the source of power by the heat discharge fan 1 and the heat discharge fan 2.

+24 VB, further, is also sent through each cover switch and is turned into +24 VAR supplied to the developing rotary motor PCB and +24 UH (Note) supplied to each PCB by way of the FET switch on the main relay PCB.

+24 VAR is used as the source of power by the color developing rotary motor and solenoids, while +24 UH is used by loads and PCBs.

+5 V is supplied to the DC controller PCB as its source of power. The DC controller PCB uses +5 V to generate the PSAVE* and P5SAVE signal, causing PSAVE* to go '0' in response to a power save command, thereby turning off the FET switch and, ultimately, cutting +24 UH. At this time, the sensors will also be deprived of power, since P5SAVE is also used by the sensors.

+5 V is also used to generate the +5 R signal to supply the printer board with 5 V power.

The low-voltage power supply circuit monitors the 5 VS signal fed back by the DC controller PCB to ensure that 5 V supplied to the printer board remains at a correct level.

Note:

+24 UH is 24 V sent through the right cover switch and the delivery cover/front cover switch and then through the FET switch; the 24 V power supplied to the heat discharge fan 3 and the pre-exposure LED without being lead through the FET switch is also called +24 UH.

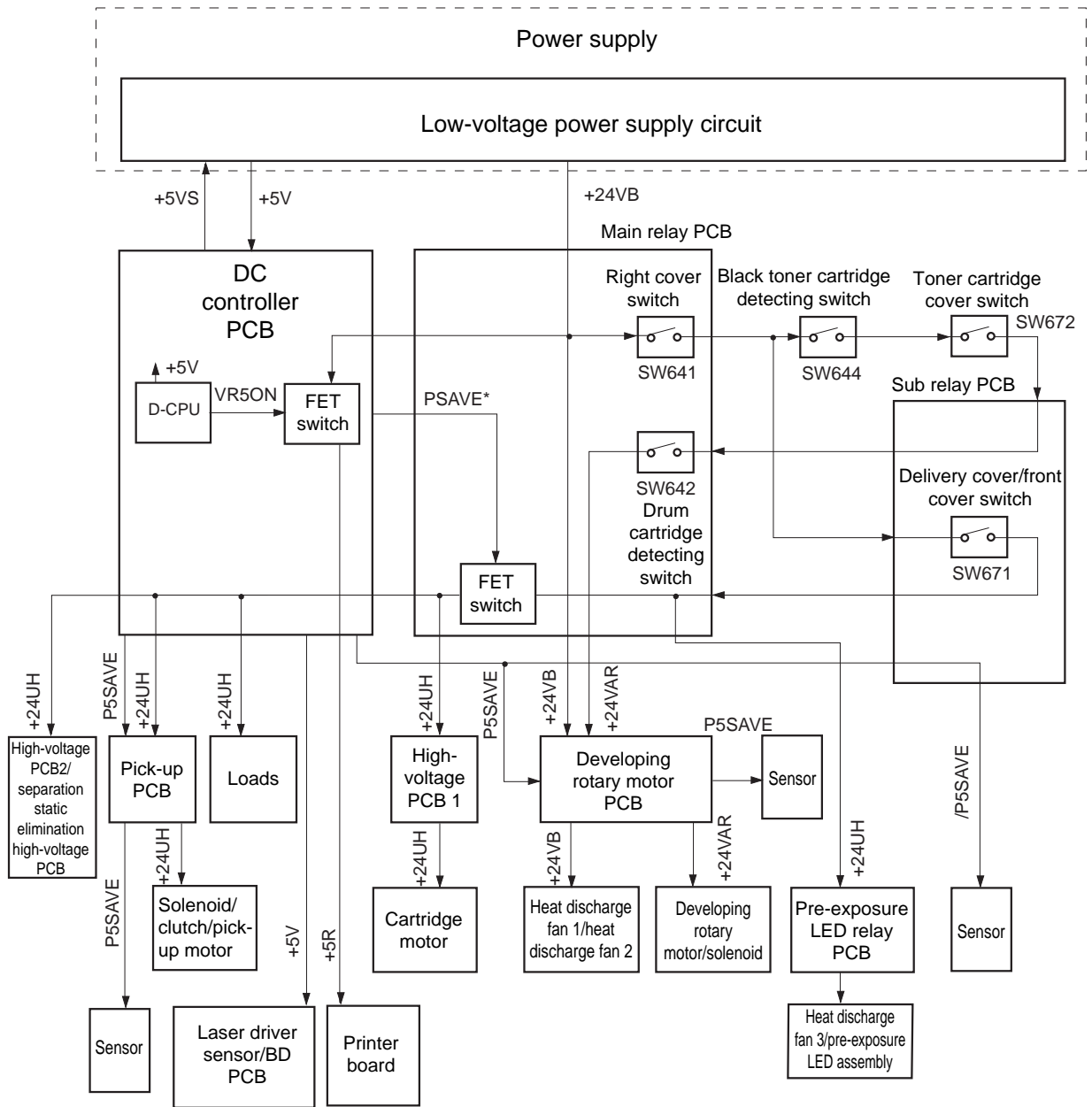

Figure 7-301

B. Remote Switch

When the machine's printer unit power switch is turned off, the low-voltage power supply circuit sends the power-off signal (POFF) to the DC controller PCB. Thereafter, when the printer unit is ready for power-off, the DC controller PCB causes the power-off control signal (PCONT) to go '1', thereby turning off the switching transistor of the power supply circuit to stop +5 V and +24 VB power.

This condition will turn off +5 R, PSAVE* and P5SAVE of the +5 V system and +24 VAR and +24 UH of the +24 VB system.

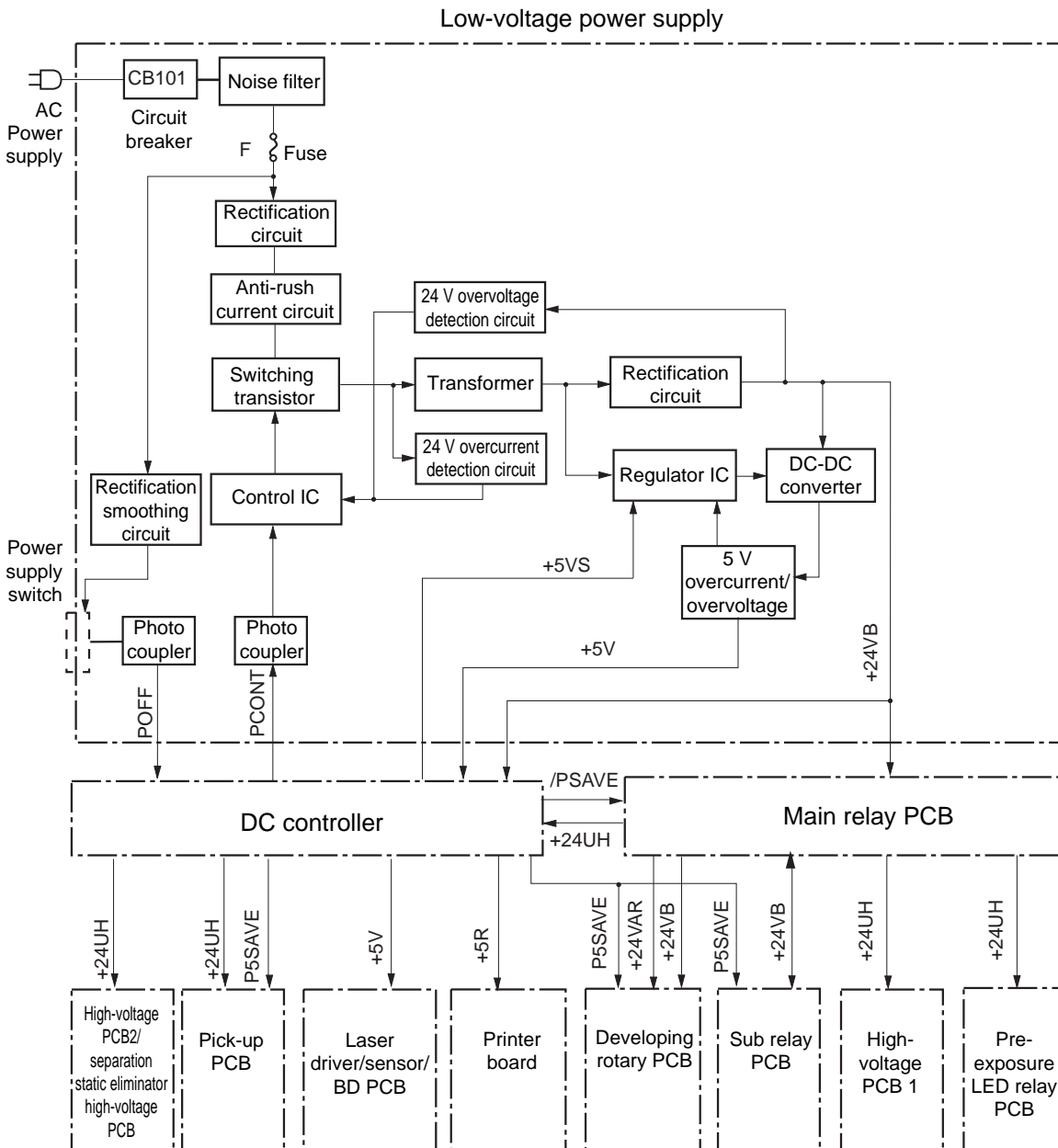

Figure 7-302

C. Protective Mechanisms

The +24 V power supply circuit and the +5 V power supply circuit are equipped with an overcurrent protective mechanism and an overvoltage protective function, which automatically shuts off output voltage to prevent damage to the power supply circuits in the event that a load should suffer a short circuit or overcurrent/overvoltage.

If the overcurrent protective mechanism or the overvoltage protective mechanism turns on to cut off the DC voltage from the low-voltage power supply circuit, turn off the power switch, disconnect the power cable, and correct the fault on the load in question; then, connect the power cable, and turn on the power switch.

The circuit is equipped with a circuit breaker (CB101) and a fuse (F1), which shut off the output voltage in response to overcurrent (i.e., CB101 turns off). If such has occurred, wait about 60 sec and then turn on the power once again.

Note that an overvoltage blows F1 to shut off the power.

D. Power Save Mode

When a power save command arrives from the printer board, the D-CPU (IC201) uses the GA (IC204) to cause the power save command signal (PSVE*) to go '0', and sends the result to the main relay PCB, turning off the FET switch on the main relay PCB to stop +24 UH.

When the PSAVE* signal goes '0', on the other hand, the switching circuit on the DC controller PCB turns on to cause the +5 V power save signal (P5SAVE) to go '0', thereby cutting power to the sensors operating under the control of the PSAVE signal.

A command ending the power save mode from the printer mode causes the power supply mechanism to resume normal mode.

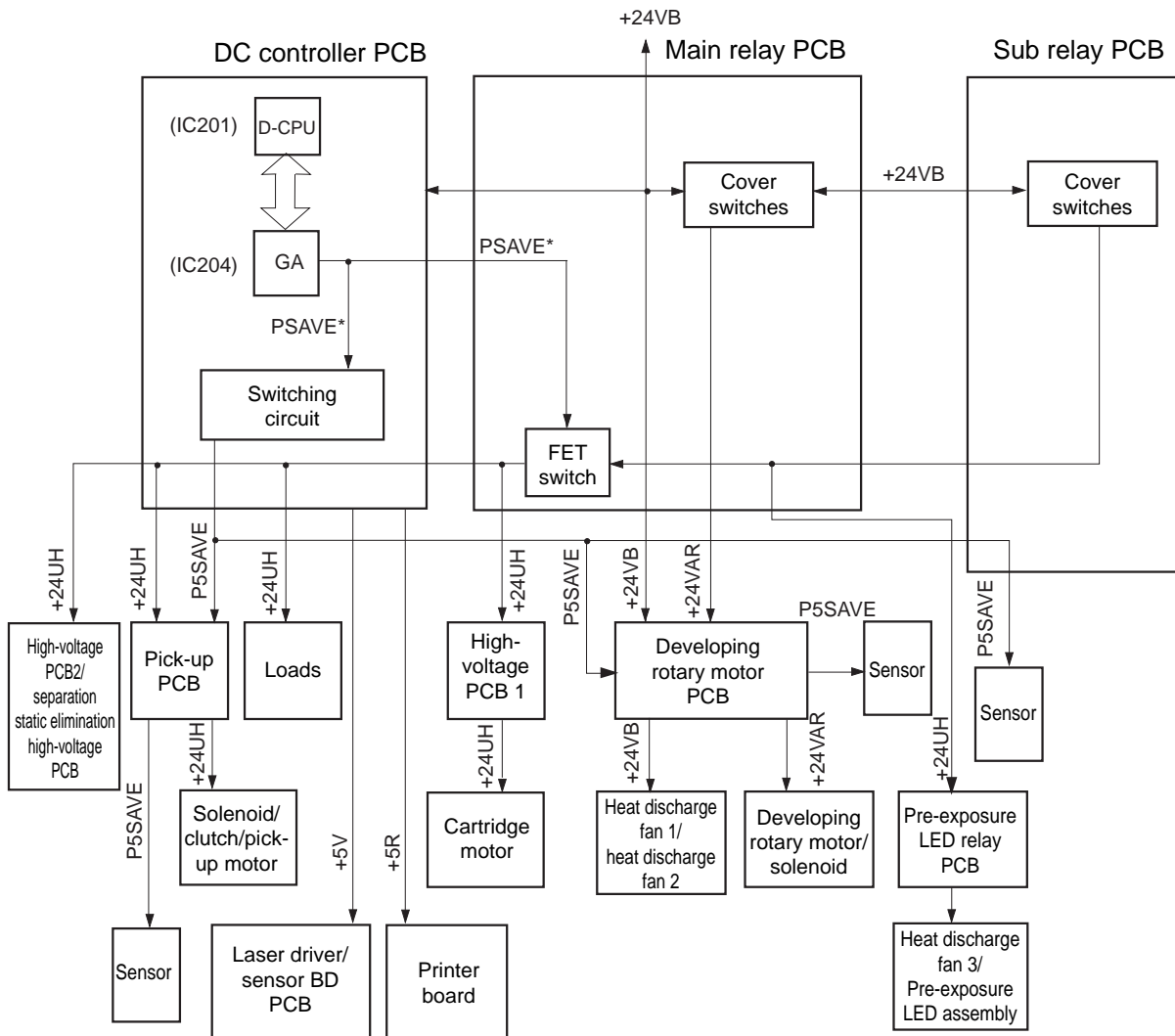

Figure 7-303

IV. DISASSEMBLY/ASSEMBLY

Make sure of the following when disassembling or assembling the machine:

1. When the printer unit power switch is turned off, the fans will operate for about 30 min to cool the machine (so as to prevent caking of toner). Be sure to perform either of the following in addition to disconnecting the power plug:
 - Wait for 30 min after turning off the printer unit power switch; or
 - Turn off the printer unit power switch, and remove the fixing assembly of the printer unit.
2. Assemble the parts by reversing the steps used to disassemble them, unless otherwise mentioned.
3. Identify the screws by type (length, diameter) and location.
4. Do not leave out the toothed washer that comes with one of the mounting screws on the rear cover to protect against static electricity.
5. Do not leave out the washer that comes with the screw used for the grounding wire and the varistor to ensure electrical continuity.
6. Do not operate the machine with any of its parts removed, unless otherwise mentioned.
7. Do not throw a toner cartridge into fire. It may explode.
8. Keep any toner cartridge in a protective cover whenever it has been taken out of the printer unit for disassembly/assembly work even for a short time.
9. Remove the cartridge and the intermediate transfer drum before disassembly/assembly work or moving the machine.
10. Touch the copier's metal section before starting the work to discharge the build-up of static electricity so as to prevent static damage before handling any PCBs.
11. To slide out the printer unit from the rack (if the reader unit is also mounted to the rack), pull halfway out the two side pins at the bottom of the rack (middle pin orientation *), and then remove the printer unit fixing member from the left of the printer unit. Be sure also to remove the printer side power cord and the interface cable.

For removal of the external covers of the printer unit, see IV.A. "External Covers of the Printer Unit" in Chapter 3.

A. Fans

1. Removing the Heat Discharge Fan (FM1; printer unit)

- 1) Perform the steps on p. 3-16 to remove the rear cover.
- 2) Disconnect the connector

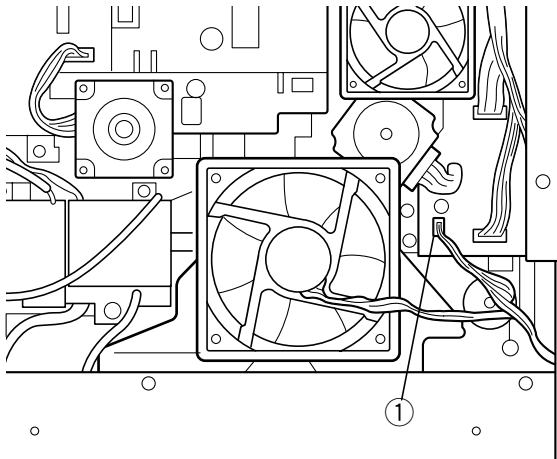

① Connector

Figure 7-401

- 3) Holding the grip lever, remove the thermistor holder. (Take care to keep it level.)

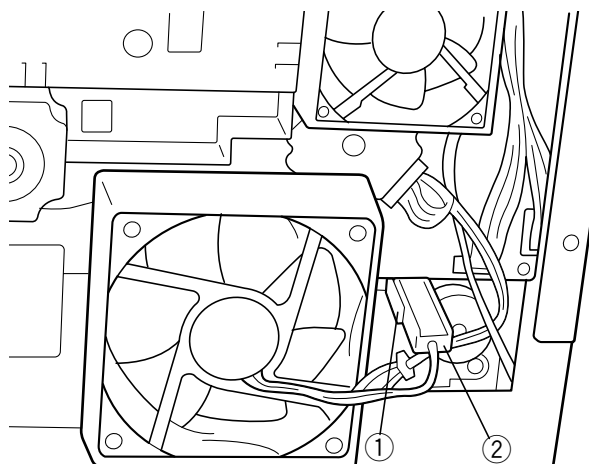

① Grip lever ② Thermistor holder

Figure 7-402

- 4) Disengage the two claws, and remove the heat discharge fan 1 together with the thermistor holder.

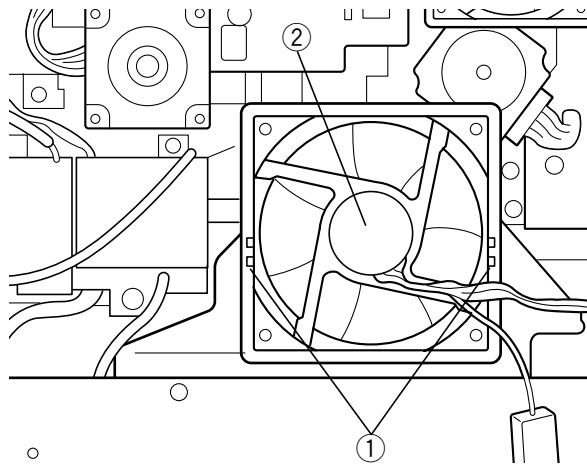

① Claws ② Heat discharge fan 1

Figure 7-403

- 5) Disengage the two claws, and slide the holder cover to detach the thermistor.

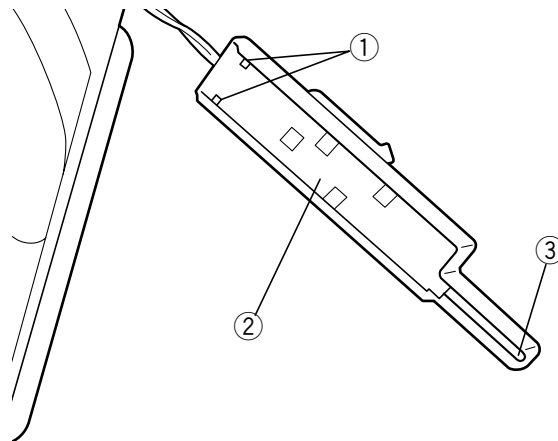

① Claws ② Holder cover
③ Thermistor

Figure 7-404

Caution:

When replacing the fan, take care not to touch the surface of the thermistor.

Caution:

When mounting the heat discharge fan, be sure that the logo of the manufacturer is toward the outside of the printer unit.

2. Removing the Heat Discharge Fan (FM2; printer unit)

- 1) Perform the steps on p. 3-16 to remove the rear cover.
- 2) Disconnect the connector, and disengage the two claws; then, detach the heat discharge fan 2.

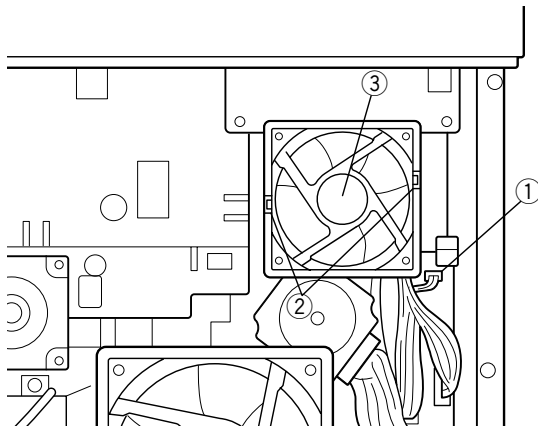

- ① Connector ② Claw
③ Heat discharge fan 2

Figure 7-405

Caution:

When mounting the heat discharge fan, be sure that the logo of the manufacturer is toward the outside of the printer unit.

3. Removing the Heat Discharge Fan (FM3; printer unit)

- 1) Perform steps 1) through 5) on p. 3-18 to remove the right cover together with the fan duct.

- 2) Disengage the two claws, and detach the duct cover.

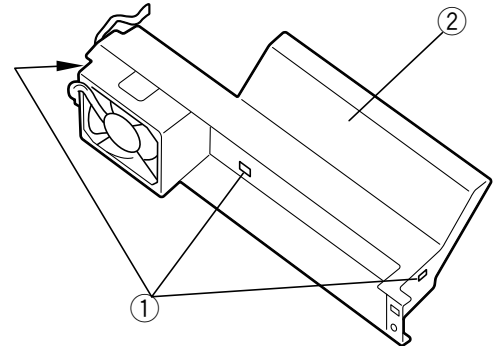

- ① Claws ② Duct cover

Figure 7-406

- 3) Slide the heat discharge fan 3 by sliding it upward.

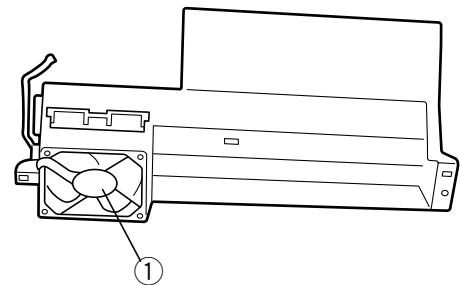

- ① Heat discharge fan 3

Figure 7-407

Caution:

When mounting the heat discharge fan, be sure that the logo of the manufacturer is toward the outside of the printer unit.

4. Replacing the Air Filter (FM1/2)

- 1) Open the exhaust vent of the printer unit.

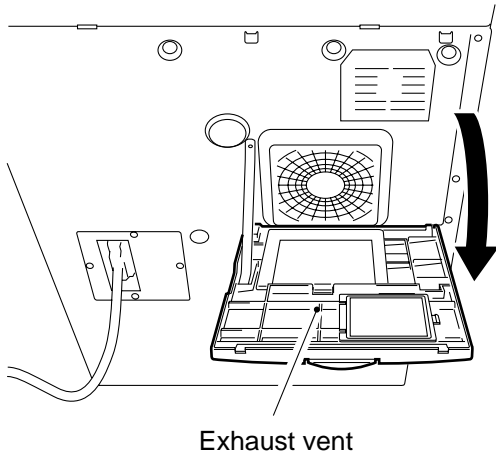

Figure 7-408

- 2) Remove the existing air filters.

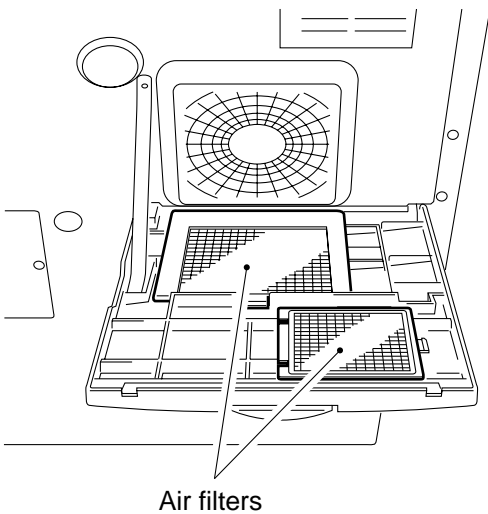

Figure 7-409

- 3) Fit the new air filters.

5. Replacing the Ozone Filter (FM3)

- 1) Open the right cover of the printer unit.

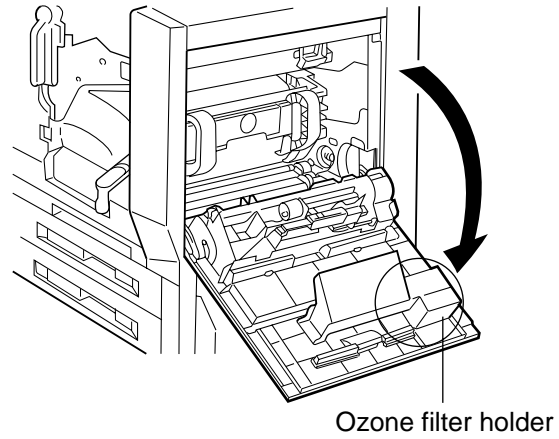

Figure 7-410

- 2) Slide the lid of the ozone filter holder.

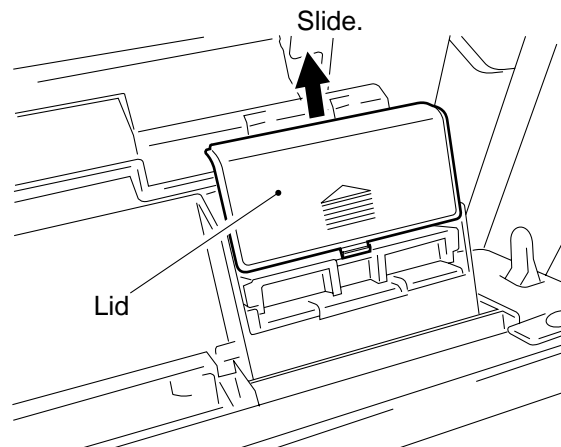

Figure 7-411

- 3) Remove the existing ozone filter.

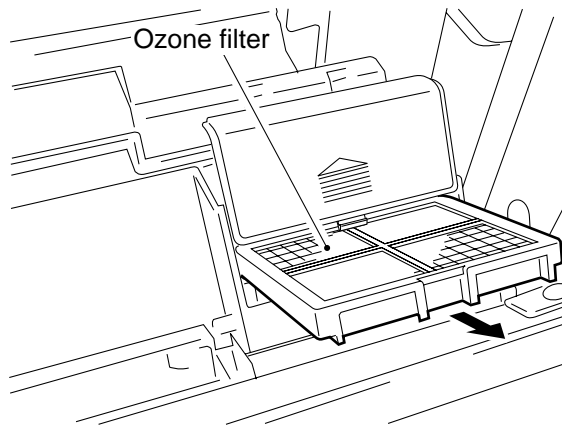

Figure 7-412

- 4) Fit the new ozone filter.
- 5) Slide the lid of the ozone filter holder back on.
- 6) Close the right cover.

B. Power Supply Assembly

1. Removing the Printer Unit Power supply

- 1) Perform steps 2) through 5) on p. 4-43 to remove the rear cover and the shielding box.
- 2) Remove the two screws, and detach the guide plate.
- 3) Remove the five screws, and disconnect the five connectors; then, detach the power supply assembly.

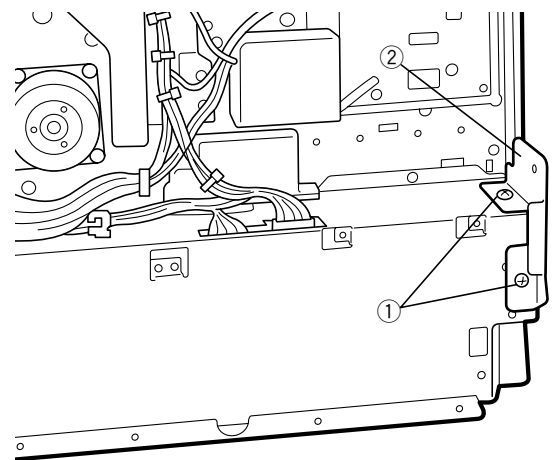

- ① Screws ② Guide plate

Figure 7-413

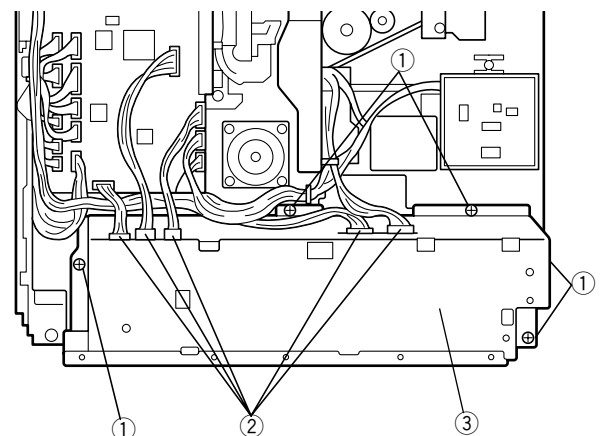

- ① Screws ② Connectors
③ Power supply assembly

Figure 7-414

CHAPTER 8

INSTALLATION

This chapter provides instructions on how to install the machine and its accessories.

I.	SELECTING THE SITE.....	8-1	C.	Selecting the Type of Message for the Printer Unit.....	8-14
II.	UNPACKING AND INSTALLATION.....	8-3	III.	RELOCATING THE MACHINE.....	8-16
	A. Unpacking the Printer Unit.....	8-3	IV.	INSTALLING THE DUPLEXING UNIT ...	8-17
	B. Installing the Printer Unit.....	8-4	V.	INSTALLING THE VERTICAL FEED CASSETTE (A4R, LTRR, B5R, A5R)	8-20
	C. Making Settings and Checking Images and Operations	8-11			

I. SELECTING THE SITE

Check the site against the following requirements; if possible, pay a visit to the user's before delivering the machine.

1. There must be a power outlet with the rated voltage ($\pm 10\%$) and that may be used exclusively by the machine. Make sure it will not be shared with another electric device. (Keep in mind that fluctuations in voltage caused by such electric devices as refrigerators, which repeat turning on and off, will affect the output images.)
2. The temperature and the humidity of the site must be as indicated in Figure 8-101. Be sure to avoid areas near water faucets, water boilers, humidifiers, and refrigerators.

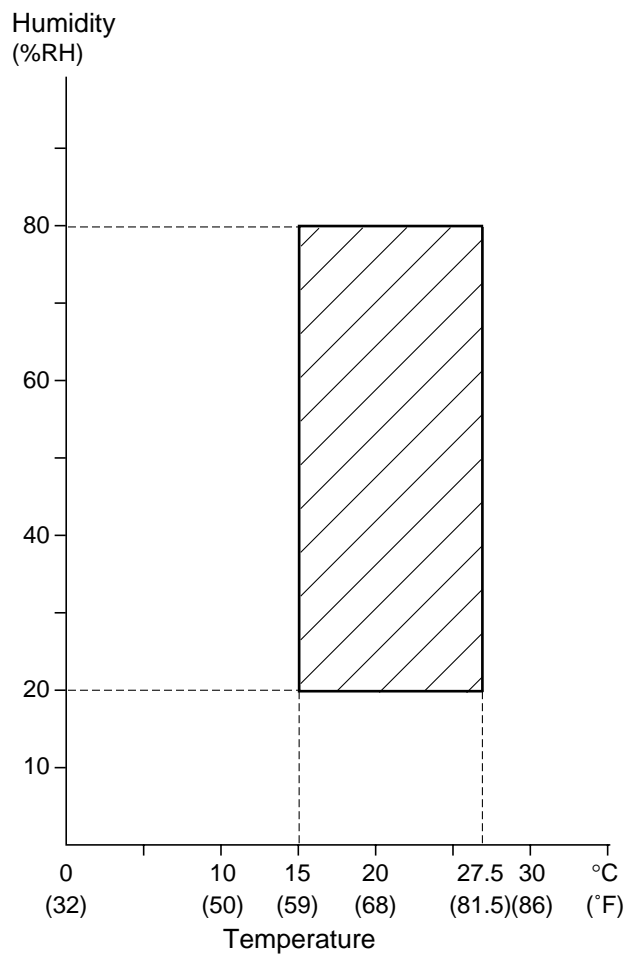

Figure 8-101 Site Environment

3. Avoid areas near a source of fire, areas subjected to dust or ammonium gas, and areas exposed to direct sunshine. As necessary, provide curtains.
4. Make sure the room will be kept well-ventilated.

Note:

The level of ozone generated by the machine will not affect the health of the individuals working around it. Some individuals, however, may find the odor to be unpleasant if the machine is used for a long time in a poorly ventilated room, indicating the importance of ventilation.

5. Be sure that the machine's feet will remain in contact with the floor, and the printer unit will remain level.
6. Be sure that there will be adequate space around the printer unit for maintenance and other work.

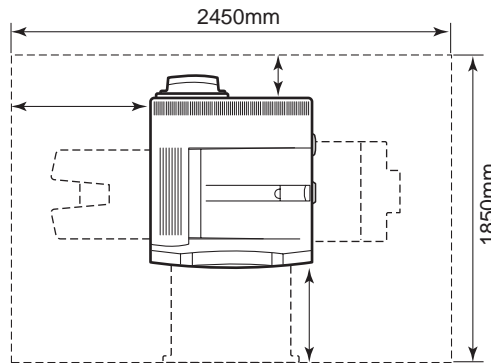

Figure 8-102

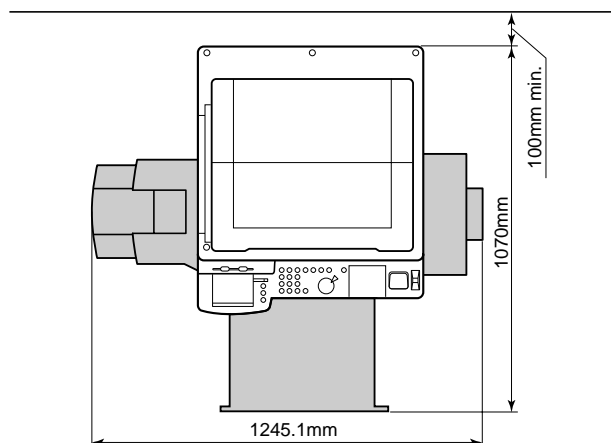

Figure 8-103 (w/ reader unit installed)

II. UNPACKING AND INSTALLATION

Bringing in a piece of metal from a cold to warm place can cause droplets of water to form on its surface. Such a phenomenon is known as *condensation*, and a printer unit suffering condensation can generate blank prints.

If the printer unit has just been brought in from a cold place, leave it alone for at least one hour before unpacking and installing it.

A. Unpacking the Printer Unit

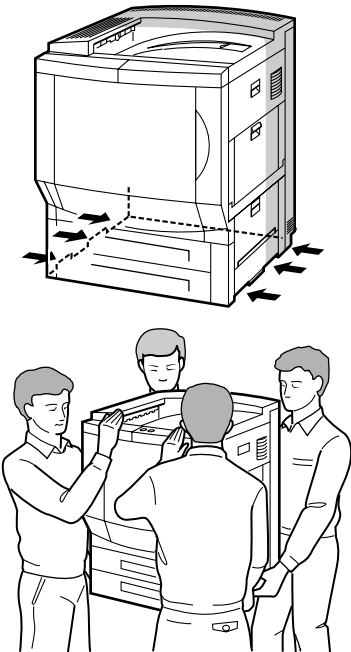
No.	Work	Remarks
1	Unpack the printer unit.	
2	<p>Caution:</p> <p>The printer unit weighs about 83 kg. Be sure to work in a group of four. Further, keep in mind that the printer unit is heavier at the rear, requiring care to maintain balance.</p> <p>Work in a group of four as shown, lift the printer unit by placing hands under its bottom, and place it at the site of installation.</p>	
3	Remove all tape from the external covers of the printer unit.	



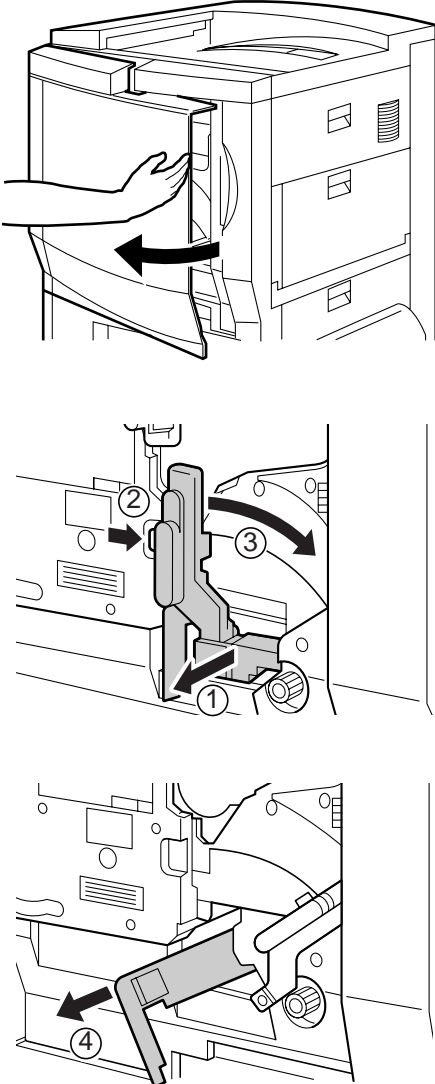
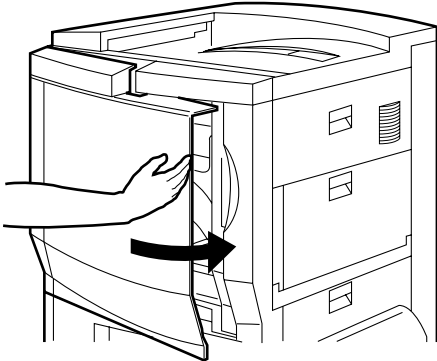

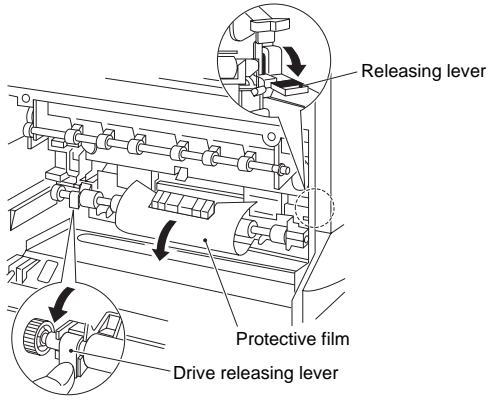
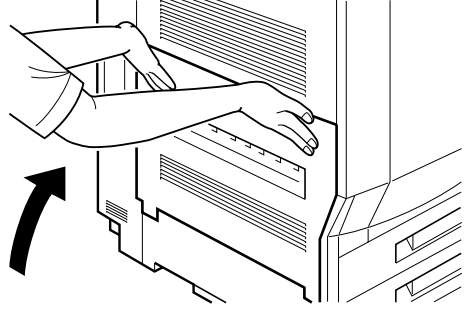
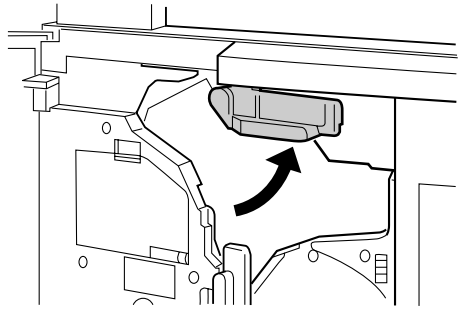
B. Installing the Printer Unit

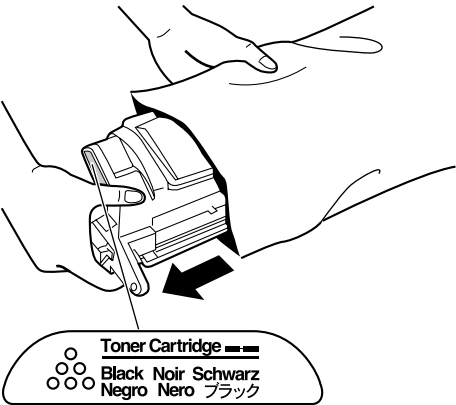
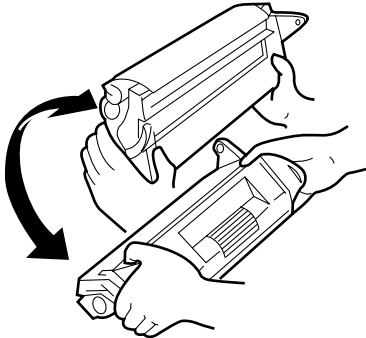
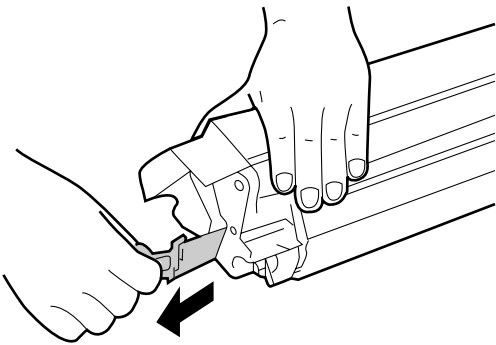
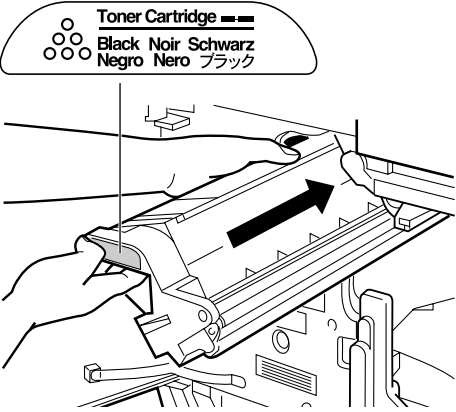
No.	Work	Remarks
1	<p>Open the front door, and remove the orange stopper ①.</p> <p>While pushing the white button ②, open the green releasing lever ③, and remove the spacer ④.</p> <div style="border: 1px solid black; padding: 5px; margin-top: 10px;"> <p>Caution: Store away the orange stopper ① for possible relocation of the printer unit in the future.</p> </div>	
2	<p>Shift the green releasing lever back to its initial position, and close the front door.</p>	

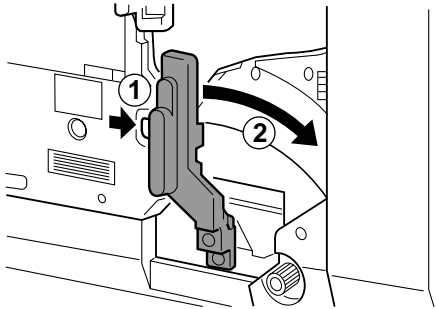
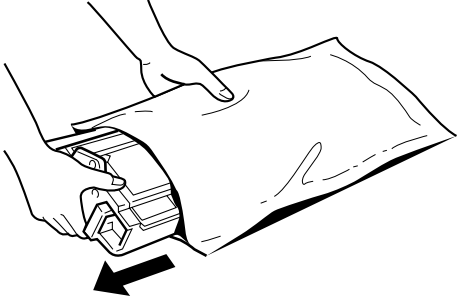
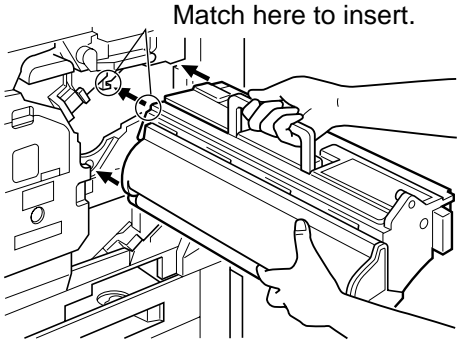
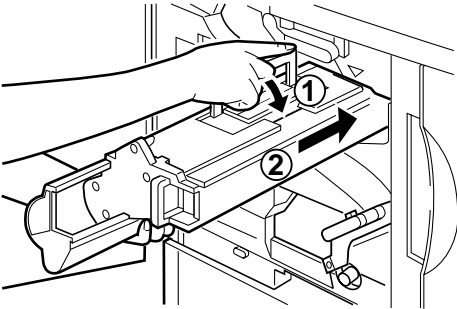
No.	Work	Remarks
3	Shift down the drive releasing lever found at the lower left of the fixing assembly in the direction of the arrow; then, pull out the protective film.	 <p>Releasing lever</p> <p>Protective film</p> <p>Drive releasing lever</p>
4	Close the printer unit delivery cover.	
5	Connect the power plug.	
6	Push the power switch found at the lower left of the printer unit to ON.	
7	Open the front door, and push up the blue releasing lever in the direction of the arrow.	

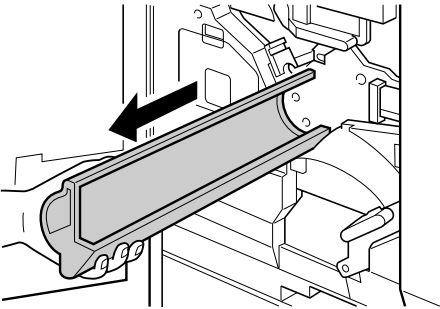
No.	Work	Remarks
8	<p>Take out the black toner cartridge from its protective bag. Holding it as shown, shake it five to six times to even out the toner inside.</p>	 
9	<p>Place the black toner cartridge on a level place; while holding the cartridge, pull out the sealing tape.</p>	
10	<p>Holding the black toner cartridge as shown, match it against the inside of the slot; then, push it fully to the end.</p>	

No.	Work	Remarks
11	While pushing the white button ①, open the green releasing lever ②.	
12	Take out the drum cartridge from the protective bag.	
13	Shift up the handle of the drum cartridge; then, holding it as shown, fit it in the drum slot.	
14	Holding the protective cover as shown, shift the handle back to its initial position; then, push the drum cartridge straight in with care.	

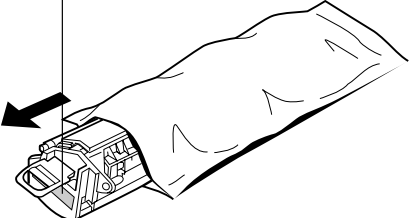
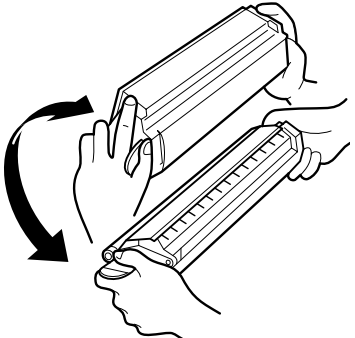
No.	Work	Remarks
15	<p>After fully inserting the drum cartridge, remove the protective cover.</p> <div style="border: 1px solid black; padding: 5px; margin-top: 10px;"> <p>Caution: Store away the protective cover for possible relocation of the machine in the future or when taking the drum cartridge out of the printer unit.</p> </div>	
16	<p>Shift the green releasing lever back to its initial position, and then put the blue releasing lever back to its initial position.</p>	 <p style="text-align: center;">Green releasing lever Blue releasing lever</p>
17	<p>Take out the yellow color toner cartridge from its protective bag; then, holding it as shown, shake it five to six times slowly to even out the toner inside it.</p>	<div style="border: 1px solid black; padding: 5px; margin-bottom: 10px;"> <p> Toner Cartridge</p> <p> Yellow</p> </div>  

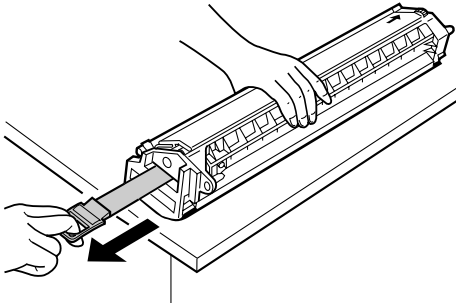
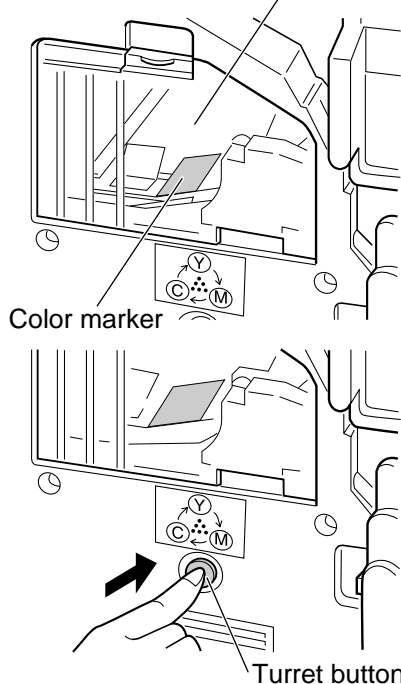
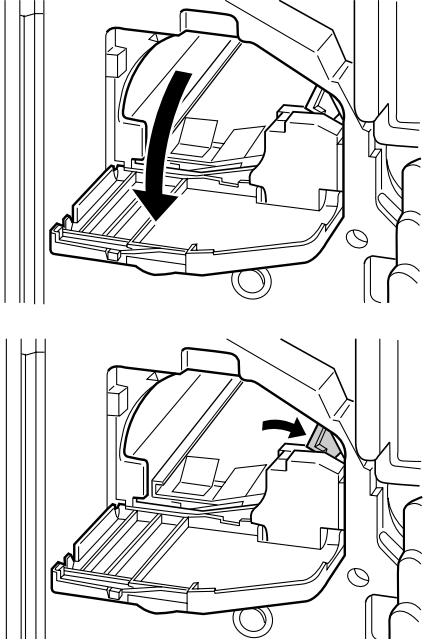
No.	Work	Remarks
18	Place the yellow color toner cartridge on a level place; then, holding the cartridge, pull out the sealing tape.	
19	Look in the color toner replacement cover to make sure that the color of the color marker on the turret is yellow. (If not, press the turret button unit it is yellow.)	<p data-bbox="1075 669 1437 696">Color toner replacement cover</p>  <p data-bbox="1043 1005 1193 1032">Color marker</p> <p data-bbox="1289 1361 1437 1388">Turret button</p>
20	Open the color toner replacement cover, and shift the blue locking lever on the right of the turret to the right.	

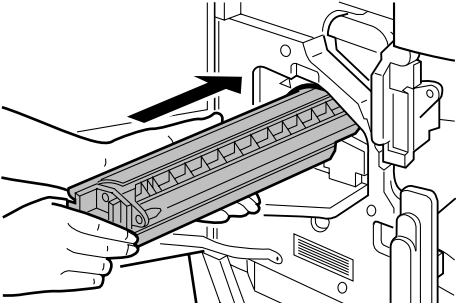
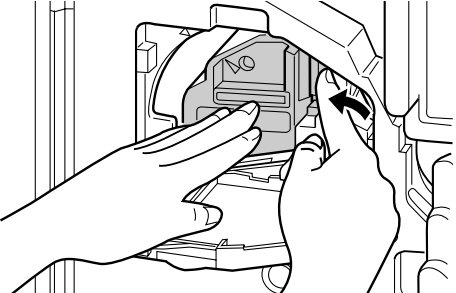
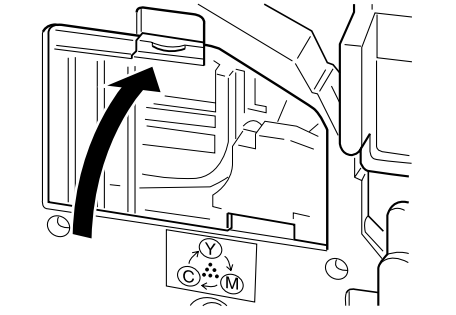
No.	Work	Remarks
21	Hold the yellow toner cartridge as shown (level), and insert it fully to the end.	
22	While pushing the yellow toner cartridge toward the rear, shift the locking lever back to its initial position to secure it in place.	
23	Close the color toner replacement cover.	
24	Perform the same steps for magenta and cyan to install each toner cartridge. (Press the turret button used in step 20) to change from yellow to magenta, and press it once again to change to cyan.)	
25	Close the front door.	

C. Making Settings and Checking Images and Operations

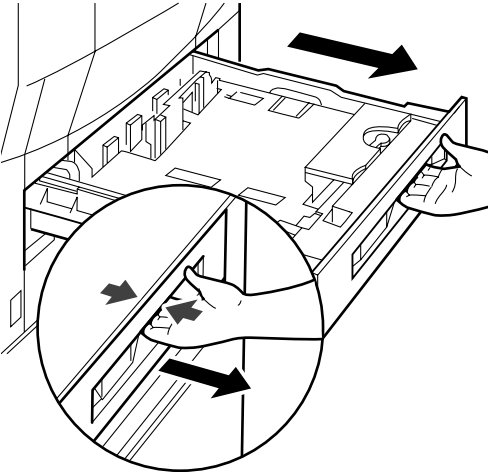
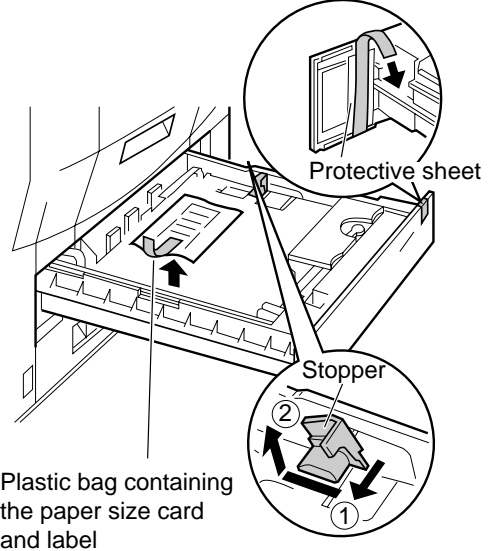
No.	Work	Remarks
1	Slide fully out the cassette 1.	
2	Remove the stopper and the protective sheet and the plastic bag containing paper size card and label from the inside of the cassette.	 <p>Protective sheet</p> <p>Stopper</p> <p>Plastic bag containing the paper size card and label</p>

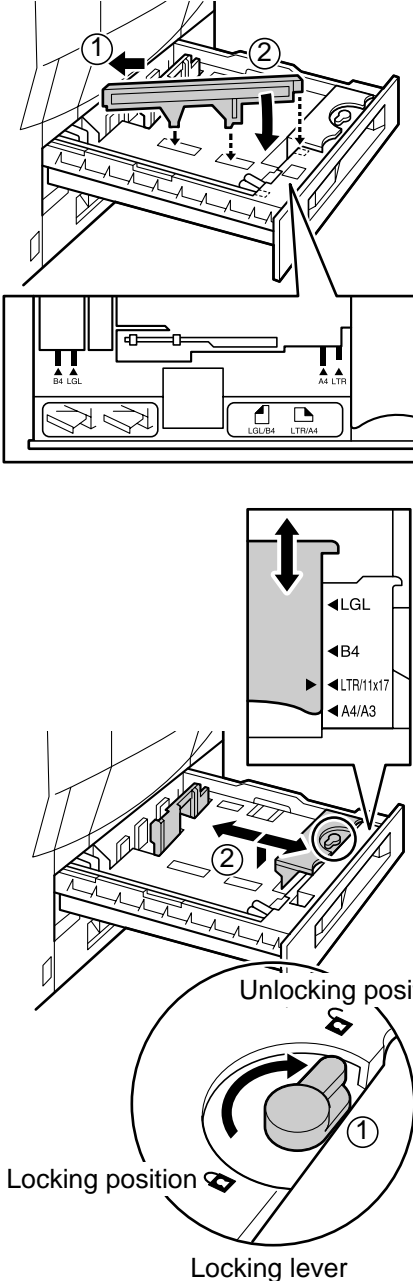
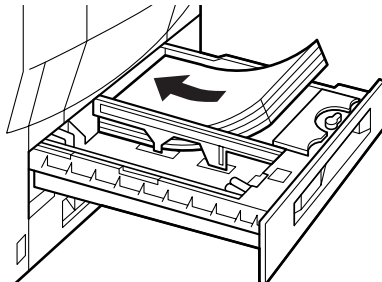
No.	Work	Remarks
3	<p>Adjust the paper guide to suit the size of the paper used most by the user.</p> <p>The pick-up cassette is equipped with a paper guide on its left end and the front and rear of its right side.</p> <p>Lift the front of the paper guide on the left end to remove; then, position it to suit the size of the paper.</p> <p>Turn the locking lever of the paper guide on the right to unlocking position ①; then, position it to suit the size of the paper ②.</p> <p>Thereafter, turn the locking lever to locking position to secure it in place.</p>	
4	<p>Place paper against the paper guides on the left and the rear.</p>	

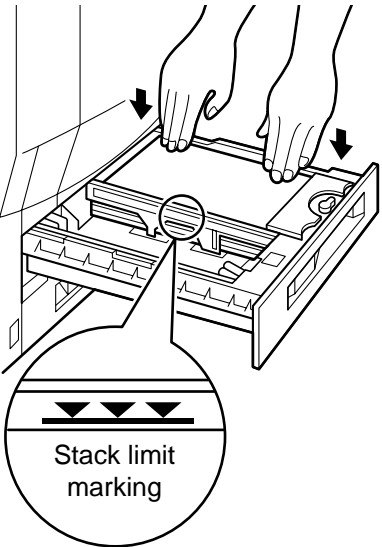
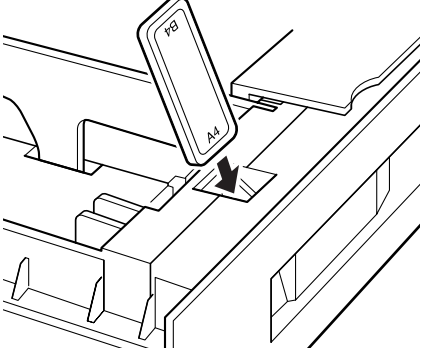
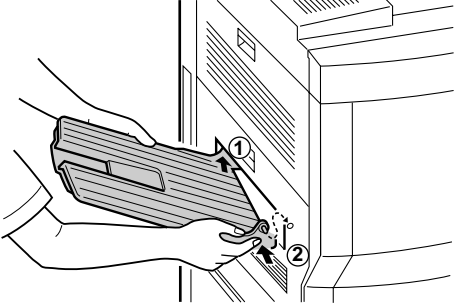
No.	Work	Remarks
5	While pushing down on the right side of the paper, check to make sure that the stack has not exceeded the limit marking.	
6	Attach the label to the paper size card to indicate the size of the paper placed in the cassette; then, fit the paper size card in the slot found at the front left of the cassette.	
7	Push the cassette fully inside. Perform the same for the cassette 2. Check to make sure that the Add Paper indicator on the control panel turns off.	
8	If the user desires face-up delivery, select side tray delivery in user mode, and mount the face-up tray. (At time of shipment, the center tray (face-down) is selected.)	
9	Check the external covers for damage and deformation.	
10	Clean up the area around the printer unit.	

D. Selecting the Type of Message for the Printer Unit

If you have installed the PS/PCL Board to the printer unit, you must select the type of message appearing on its control panel.

- EUROPE for service maintenance
- JAPAN not used
- UNITED STATES for user maintenance
- UNKNOWN not used
- EUROPE2 not used
- JAPAN2 not used
- UNITED STATES2 for service maintenance

The default setting is UNITED STATES (i.e., for user maintenance).

To change the type of message, perform the following:

No.	Work	Remarks
1	Turn off the printer unit.	
2	Check to make sure that the jumper head is fitted to J27 of the PS/PCL Board.	
3	Install the PS/PCL Board to the printer unit.	
4	While holding down the Menu and \vee key on the control panel of the printer unit, turn on the printer unit. At this time, be sure to hold down the two keys until the message 'START SELF-TEST' appears.	
5	Wait until the printer unit has run self diagnosis, and indicates the message 'VERSION INFO'	If the printer unit has started without displaying the message, turn it off, and start with step 4.
6	Press the Menu key several times so that the message 'CHANGE DEFAULT LOCALE:' appears.	
7	Press the Enter key.	
8	When 'DEFAULT LOCALE:' has appeared, select the item that indicates the site of installation using the \wedge or \vee key. (The currently selected item is indicated by the asterisk * on the last digit.)	<ul style="list-style-type: none"> • EUROPE for service maintenance • JAPAN not used • UNITED STATES for user maintenance • UNKNOWN not used • EUROPE2 not used • JAPAN2 not used • UNITED STATES2 for service maintenance <p>The default setting is UNITED STATES (i.e., for user maintenance).</p>

No.	Work	Remarks
9	After making the selection, press the Enter key. The message 'LOCALE STORED' will appear and remain for about 1 sec, to be replaced by the message 'CHANGE DEFAULT LOCALE:'.	
10	Turn off the printer unit, and remove the PS/PCL Board from the printer unit.	
11	Detach the jumper head J27 of the PS/PCL Board, and install the PS/PCL Board to the printer unit once again.	Be sure to detach the jumper head from J27, and store away the head for future use.
12	Turn on the printer unit.	

■ Making Sure of the Change

- You can start the printer unit and print a start page. (Check the name of the product, which differs according to the site of installation.)
- While the machine is in ready state, remove the photosensitive drum unit, and close the front door. If 'INSTALL DRUM CARTRIDGE' appears on the control panel of the printer unit, the machine is set for user maintenance; if 'SERVICE CALL E810' appears, it is set for service maintenance.

Caution:

- If the jumper head is not fitted to J27, the menu for 'CHANGE DEFAULT LOCALE:' will not appear during the above procedure.
- Do not change any items except 'CHANGE DEFAULT LOCALE:'.

III. RELOCATING THE MACHINE

If the machine must be moved by truck or any other means of transportation after installation, perform the following steps.

The printer unit is designed to rotate its fans for 30 min after the power switch is turned off to prevent overheating inside it. Be sure that the fans are not rotating before starting the work.

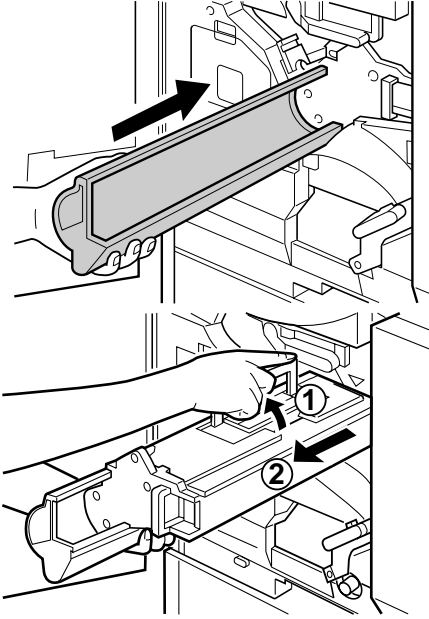
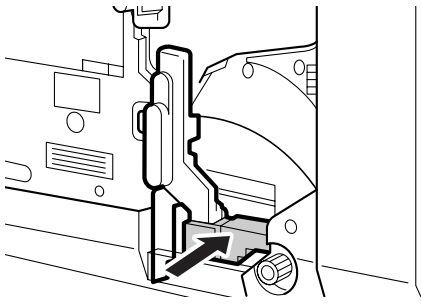
No.	Work	Remarks
1	Take out the toner cartridges (Y, M, C, Bk).	
2	Obtain the drum cartridge cover (MF4-0106) taken out when installing the drum cartridge. Set it as shown, and take out the drum cartridge while keeping it level.	
3	Take out the orange fixing member used for the secondary transfer belt.	

IV. INSTALLING THE DUPLEXING UNIT

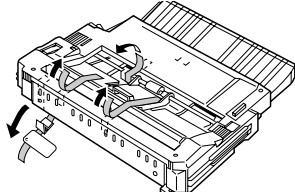
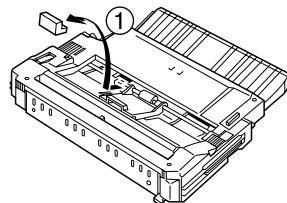
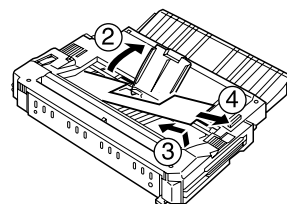
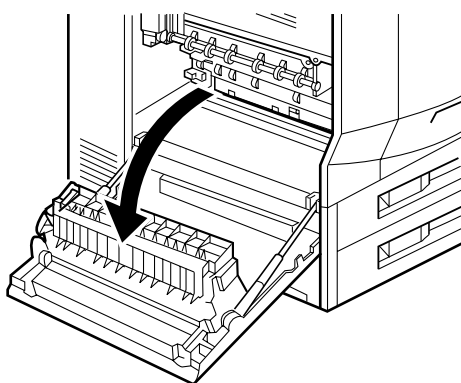
No.	Work	Remarks
1	Turn off of the printer unit.	
2	Unpack the duplexing unit.	
3	Remove the tape, stopper, and spacers from the duplexing unit.	 <p data-bbox="1133 705 1348 739">Remove the tape.</p>  <p data-bbox="1125 974 1372 1008">Remove the stopper.</p>  <p data-bbox="1125 1243 1380 1276">Remove the spacers.</p>
4	<p data-bbox="359 1305 901 1339">Open the printer assembly delivery cover.</p> <div data-bbox="359 1377 949 1668" style="border: 1px solid black; padding: 5px;"> <p data-bbox="406 1384 518 1411">Caution:</p> <p data-bbox="383 1417 933 1657">The areas near the fixing assembly and the delivery assembly behind the printer unit delivery cover are hot, possibly burning the skin upon contact. If the printer unit has been used, turn it off, and wait for a while for its inside to cool before starting the work.</p> </div>	

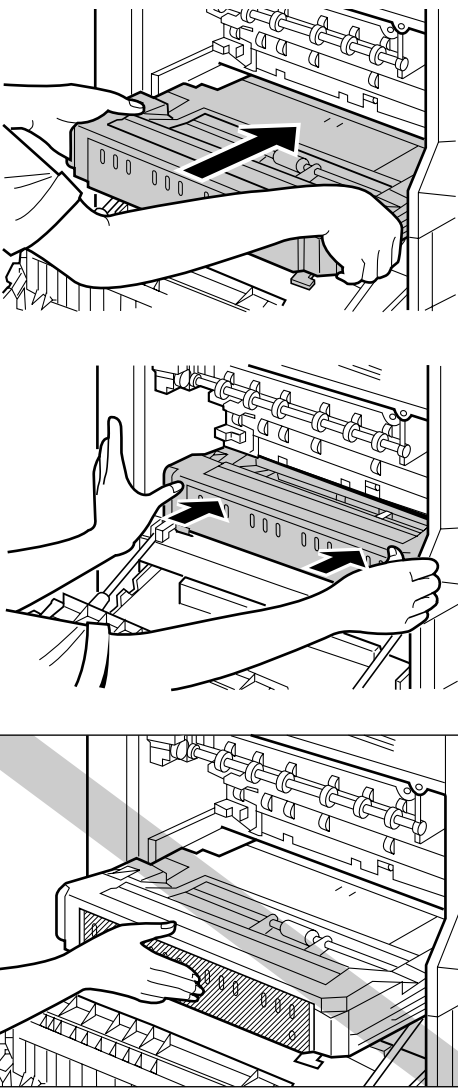
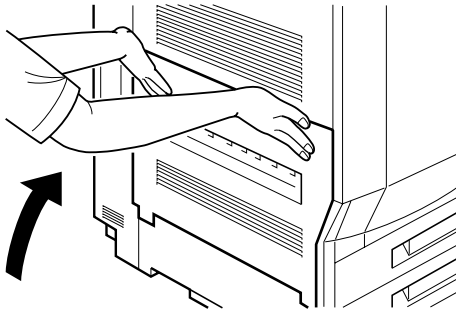
No.	Work	Remarks
5	<p>Hold the duplexing unit as shown, and insert it into the slot for the duplexing unit. (When inserting it halfway, put your thumbs on its both sides; then, push it fully inside.)</p> <div data-bbox="233 1070 820 1263" style="border: 1px solid black; padding: 5px; margin-top: 20px;"> <p>Caution: Do not push on the metal plate at the back of the duplexing unit; otherwise, the plate may deform to cause pick-up faults or jams.</p> </div>	
6	<p>Close the printer unit delivery cover. (Be sure to push with both hands until a click is heard, indicating that it has locked into place.)</p>	

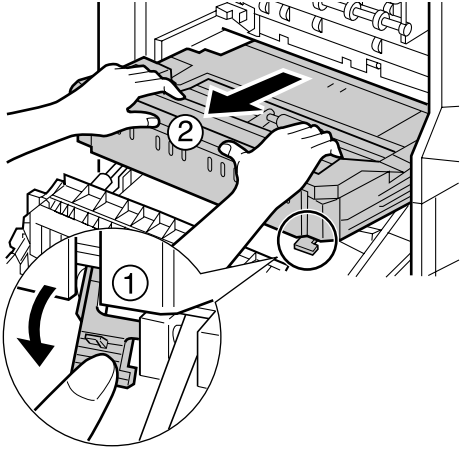
No.	Work	Remarks
7	<p>When taking out the duplexing unit, push down the locking lever found at the lower right of the duplexing unit; then, slide it using both hands out of the printer unit.</p> <p>Caution: Do not push on the metal plate found at the back of the duplexing unit; otherwise, the plate may deform to cause pick-up faults or jams.</p>	 <p>Locking lever</p>

V. INSTALLING THE VERTICAL FEED CASSETTE (A4R, LTRR, B5R, A5R)

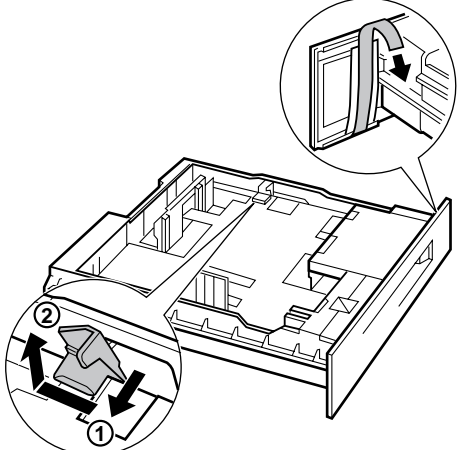
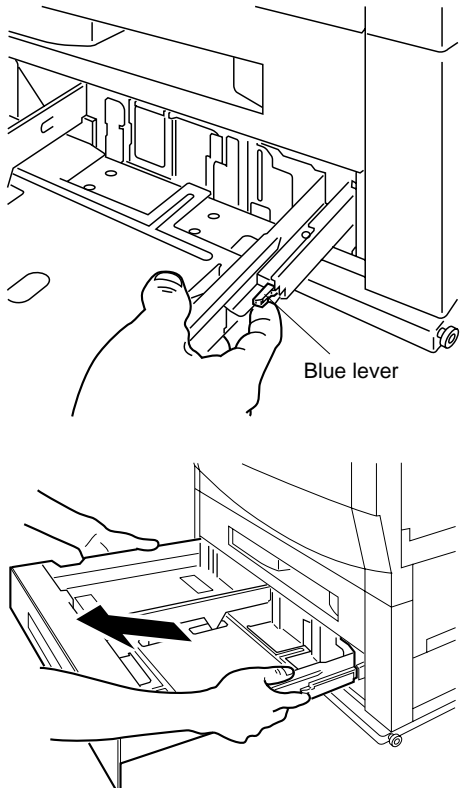
No.	Work	Remarks
1	Unpack the vertical feed cassette.	
2	Remove the stopper and the protective sheet from inside the vertical feed cassette.	
3	Slide out the cassette 1 (upper; standard); then, while shifting up the blue lever with your finger, lift the cassette 1 slightly to remove.	

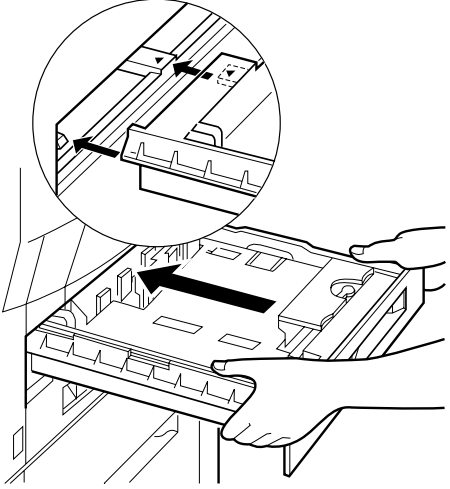
No.	Work	Remarks
4	<p>Match the groove in the bottom of the vertical feed cassette and the left side with the guide on the printer unit to set the cassette to the printer unit.</p> <p>Caution:</p> <p>The vertical feed cassette is designed for the holder for the cassette 1 only. Be sure not to force it inside at an angle (top/bottom, let/right).</p>	 <p>Match the triangle markings on the printer unit and the triangle markings on the pick-up cassette; then, place the left side of the cassette on the copier's guide.</p>

CHAPTER 9

MAINTENANCE AND SERVICING

This chapter discusses those of the machine's parts that require inspection and maintenance.

I. PERIODICALLY REPLACED PARTS.....9-1	III. BASIC SERVICING CHART9-2
II. CONSUMABLES AND DURABLES9-1	

I. PERIODICALLY REPLACED PARTS

The printer unit does not have parts that must be replaced on a periodical basis.

II. CONSUMABLES AND DURABLES

December 31, 1998

No.	Parts name	Parts Nol.	Q'ty	Life (copies)	Remarks
1	Intermediate transfer drum unit	RG5-3039-000	1	37,500	
2	Fixing assembly	RG5-3995-000	1	50,000	100/120V
		RG5-3996-000	1	50,000	220/240V
3	Secondary transfer belt assembly	RG5-3047-000	1	37,500	
4	Intermediate transfer drum (ITD) cleaning roller	RG5-3975-000	1	75,000	
5	Separation static eliminating assembly	RG5-3973-000	1	150,000	
6	Multifeeder pick-up roller	RB1-9526-000	1	200,000	Must be replaced simultaneously.
7	Multifeeder separation pad	RF5-1989-000	1	200,000	
8	Cassette feeding roller	RF5-1834-000	2	150,000	Cassettes 1 and 2 are interchangeable. Feeding roller and separation roller must be replaced simultaneously.
9	Cassette separation roller	RF5-1834-000	2	150,000	
10	Air filter (FM1)	RB1-9807-000	1	5,800	Must be replaced simultaneously with drum cartridge.
11	Air filter (FM2)	RB1-9808-000	1	5,800	
12	Ozone filter (FM3)	RB1-9836-000	1	75,000	
13	Heat discharge fan 1 (FM1)	RH7-1330-000	1	30,000 hr	Reference only; in terms of hours used.
14	Heat discharge fan 2 (FM2)	RH7-1373-000	1	30,000 hr	
15	Heat discharge fan 3 (FM3)	RH7-1393-000	1	30,000 hr	
16	Toner catch tray	RB1-9804-000	1		See Note.

The values are estimates only and are subject to change based on future data.

Note:

The toner catch tray must be cleaned to prevent caking of toner by the heat from fixing. Replace the tray only when the cake of toner cannot be removed.

III. BASIC SERVICING CHART

The printer unit does not have parts that require periodical servicing. The following work is recommended to prolong the life of each part and, ultimately, the life of the printer unit itself.

Items to Clean

Unit	Part	Remarks
Pick-up feeding	Multifeeder roller Cassette pick-up roller Feeding roller 1 Feeding roller 2 Separation roller	Use lint-free paper or alcohol.
	Separation pad	Use lint-free paper.
	Registration roller assembly	Use lint-free paper. If the dirt cannot be removed, use alcohol on the rubber area and solvent on other areas. Do not remove the spring when cleaning; a displaced spring will cause skew movement of paper or jams. Correct the spring if displaced.
	Separation guide	Use lint-free paper.
	Transparency sensor 1/2	Use a blower brush.
Development	Sub cover sheet	Use lint-free paper or alcohol.
	Toner catch tray	Remove any cake of toner.
Fixing assembly	Fixing assembly inlet guide	Use solvent.
	Upper/lower fixing separation guide	Use solvent to remove cakes of toner. (Do not force.)
Intermediate transfer drum	Density sensor	Use the special brush.
	Pre-exposure LED assembly	
Charging assembly	Secondary pre-transfer charging assembly	Use a cleaning lever.
	Separation static assembly	

Note:

1. As a rule, do not clean the following:
 - ITD cleaning roller
 - Photosensitive drum cartridge
 - Secondary transfer belt assembly
2. The surface of the intermediate transfer drum may develop condensation during installation work. If such happens, dry wipe the surface with lint-free paper. If the output images are soiled, suspect dirt on the surface of the intermediate transfer drum. To correct, wipe it with a flannel cloth moistened with water, and then dry wipe it with lint-free paper.

Work as follows:

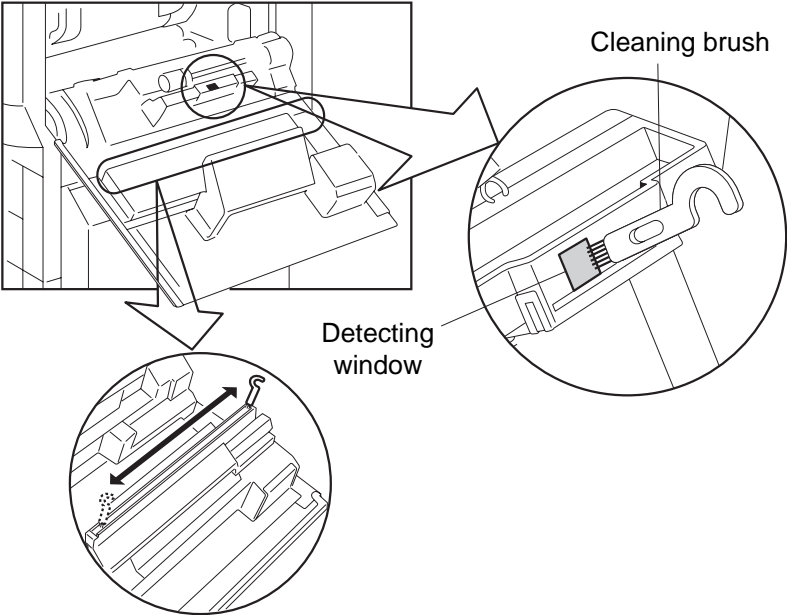
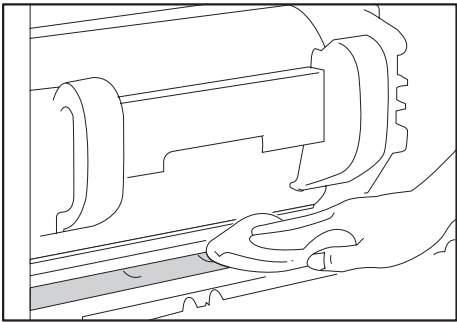
Item	Description
<p>Density sensor Pre-exposure LED assembly</p>	<p>Use the density sensor cleaning brush attached to the printer unit to clean the detecting window of the sensor. For the pre-exposure LED assembly, move the same brush in the direction of the arrow to clean each LED.</p> 
<p>Registration roller assembly</p>	<p>When replacing each drum cartridge, clean the registration roller assembly.</p> 

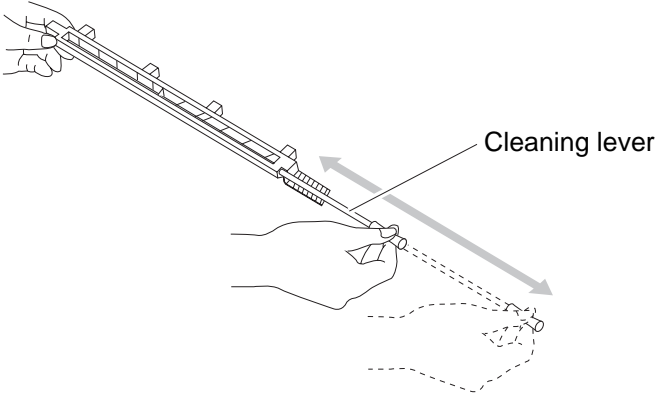
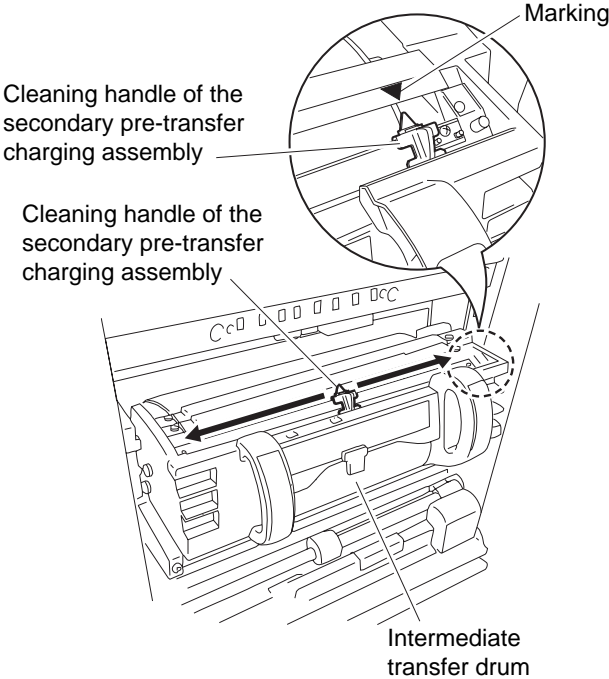
Item	Description
<p>Separation static eliminating</p>	<p>Remove the separation static eliminator from the printer unit. Then, move the cleaning lever in the direction of the arrow several times to clean it.</p>  <p style="text-align: right;">Cleaning lever</p> <p>Note: _____ After cleaning, be sure to fit the cleaning lever in the static eliminator before mounting it back to the printer unit.</p>
<p>Secondary pre-transfer charging assembly</p>	<p>Move the cleaning handle of the secondary pre-transfer charging assembly in the direction of the arrow several times to clean the secondary pre-transfer charging assembly</p>  <p style="text-align: right;">Marking</p> <p>Cleaning handle of the secondary pre-transfer charging assembly</p> <p>Cleaning handle of the secondary pre-transfer charging assembly</p> <p style="text-align: right;">Intermediate transfer drum</p> <p>Note: _____ After cleaning, be sure to move the cleaning handle of the secondary pre-transfer charging assembly to the right end where a marking is found.</p>

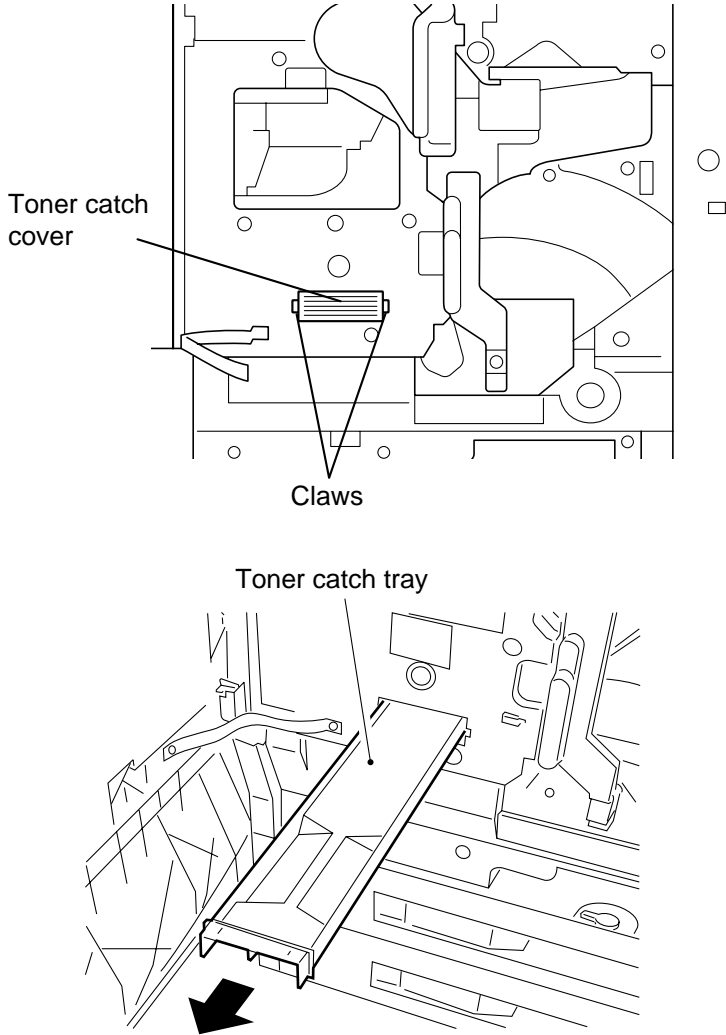
Item	Description
<p>Toner catch tray</p>	<p>Disengage the two claws of the toner catch tray cover, and slid out the toner catch tray.</p>  <p>The diagram consists of two parts. The upper part is a cross-sectional view of the toner catch tray assembly. It shows a rectangular 'Toner catch cover' positioned over a 'Toner catch tray'. Two 'Claws' are shown on the left side of the cover, which are being disengaged from the tray. The lower part of the diagram shows the 'Toner catch tray' being pulled out of the machine's chassis, with a black arrow indicating the direction of removal.</p> <p>Remove any cake of toner. However, if the cake of toner cannot be removed, replace the toner catch tray.</p>

CHAPTER 10

TROUBLESHOOTING

This chapter provides standards/adjustments, instructions on how to troubleshoot faulty images, malfunctions, and feeding faults, shows the arrangement/functions of electrical parts, and explains service mode and self diagnosis.

I.	STANDARDS AND ADJUSTMENTS	10-1	B.	Thermistors, Lamps, and Heaters	10-72
A.	Electrical System	10-1	C.	Clutches and Solenoids	10-74
II.	TROUBLESHOOTING IMAGE		D.	Fans and Motors	10-75
FAULTS	10-10	E.	PCBs	10-76	
A.	Making Initial Checks	10-10	F.	Duplexing Unit	10-78
B.	Guide to Test Prints for the Printer		G.	Variable Resistors (VR), Light-Emitting	
Unit	10-12		Diodes, and Check Pins PCB	10-79	
C.	Troubleshooting Image Faults	10-14	VI.	SERVICE MODE	10-83
III.	TROUBLESHOOTING		A.	Entering the Service Mode	10-83
MALFUNCTIONS	10-28		B.	Menu Structure and Key	
A.	Error Codes	10-29	Assignment	10-83	
B.	Faults Not Identified by Error		C.	Main Menu	10-85
Codes	10-45		VII.	TEST PAGE PRINT MODE	10-93
IV.	TROUBLESHOOTING FEEDING		A.	Generating the Test Page	10-93
PROBLEMS	10-58		B.	Test Pattern	10-93
A.	Paper Jams	10-58	VIII.	SELF DIAGNOSIS	10-99
B.	Faulty Feeding	10-66	A.	Printer unit	10-99
V.	ARRANGEMENT AND FUNCTIONS OF				
ELECTRICAL PARTS	10-69				
A.	Sensors	10-70			

Guide to Tables

The tables used in this Service Handbook have been prepared from flow charts; study the sample table below.

AC power is absent.

Cause	Step	Check	Yes/No	Action
Power plug	1	Is the power plug connected to the outlet?	NO	Connect the plug.
Covers	2	Are the front door and/or delivery cover closed properly?	NO	Close the door and/or cover properly.
Power source	3	Is the rated voltage (100 VAC) present at the outlet?	NO	The problem is not of the copying machine; advise the user.
	4	Is the rated voltage present between J 1-1 and J 1-2?	YES	Check step 6) and onward.

- To find the cause (faulty part) for a single problem, see the items under "Cause." For "AC power is absent," the cause may be the power plug, covers, or power source.
- To find checks to make or actions to take for a single problem, make checks in the order given, answer the question Yes or No, and take the action given; move onto the next step as necessary.

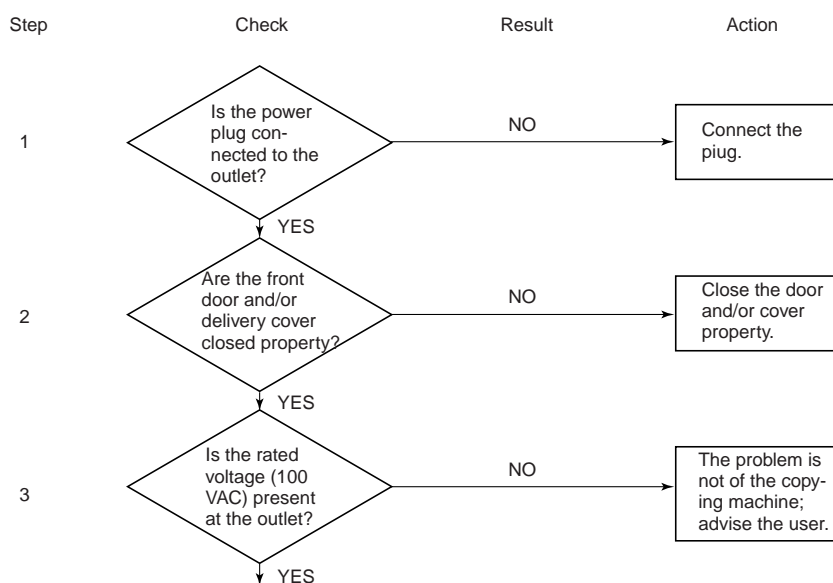

- Checks on the voltage using a tester call for special note; the description "Check the voltage between J 109-1 (+) and J 109 (-) on the DC controller PCB" means that the positive probe of the tester should be connected to J 109-1 (+) and the negative probe, to J 109-2 (-).

■ The left door switch goes OFF and, at the same time, the laser shutter closes as soon as the front left door is opened; as such, put the door switch actuators into left door switch and laser shutter if the machine needs to be opened with its front left door open. **DO NOT BLOCK THE LASER PATH WITH LIGHT REFLECTING OBJECTS.**

I. STANDARDS AND ADJUSTMENTS

A. Electrical System

1	When Replacing the DC Controller PCB
----------	---

- Without the Reader Unit Installed (with the printer board installed)
 - 1) Connect the power plug to the power outlet; and while holding on the “Menu key, Enter/Online key, and Cancel key” on the control panel at the same time until “Start SELF-TEST” displays. The panel displays will show “Display” to indicate that service mode has started after the printer unit checks itself.
 - 2) Using the Menu key on the control panel, select “READ MEMORY”.
 - 3) Press the ENTER key to select “READ FROM DCON”.
 - 4) Using the \wedge or \vee key, select ‘YES’.
 - 5) Press the ENTER key to execute.
 - 6) See that “READ FROM DCON EXECUTING>” is indicated.
 - 7) Turn off the printer unit power switch and disconnect the power plug.
 - 8) Perform the steps under VIII.C.4 “Removing the DC Controller PCB” in Chapter 4 to remove the DC controller PCB and mount the new DC controller PCB.
 - 9) Put back the parts that have been removed. (However, it is better not to mount the rear cover of the printer unit until after checking to see that copier operates normally.)
 - 10) Connect the power plug to the power outlet; and enter the service mode once again.
 - 11) Using the Menu key on the control panel, select “WRITE MEMORY”.
 - 12) Press the ENTER key to select “WRITE TO DCON”.
 - 13) Using the \wedge or \vee key, select ‘YES’.
 - 14) Press the ENTER key to execute.
 - 15) See that “WRITE TO DCON EXECUTING>” is indicated.
 - 16) End.

Reference:

For details of “READ MEMORY” and “WRITE MEMROY,” see p. 10-88 and p. 10-92.

- With the Reader Unit Installed

- 1) Perform the steps under VIII.C.4. "Removing the DC Controller PCB" in Chapter 4 to remove the DC controller PCB.
- 2) Mount the new DC controller PCB.
- 3) Put back the parts that have been removed. (However, it is better not to mount the rear cover of the printer unit until after checking to see that the copier operates normally.)
- 4) Connect the power plug to the power outlet, and turn on the reader unit rear power switch and the control panel power soft switch in the order indicated.
- 5) Operating on the control panel of the reader unit, select COPIER>FUNCTION>MISC-P>DC-LOAD to highlight; then, press the OK key.
- 6) End service mode, and turn off and then on the control panel power soft switch to load the data backed up on the reader controller PCB to the DC controller PCB (all items of ADJUST>IMG-REG, FEED-ADJ, HV-TR).
- 7) Check to make sure that settings are indicated under ADJUST>IMG-REG, FEED-ADJ, HV-TR; if not, perform the steps starting with step 5). If settings are still absent, enter the value recorded on the service label attached to the printer unit for ADJUST>IMG-REG, FEED-ADJ, and enter the standard value for ADJUST>HV-TR.
- 8) Execute auto gradation correction in user mode.
- 9) End.

2 Checking the Photointerrupters

The machine's photointerrupters may be checked either using a conventional meter or in service mode (by operating on the control panel of the printer unit). (If the reader unit is installed, you may use the control panel of the reader unit.)

a. Using a Meter

- 1) SET the meter range to 30 VDC.
- 2) Connect the - probe of the meter to GND on the DC controller PCB.
- 3) Connect the + probe of the meter to the terminals (on the DC controller PCB) indicated on the pages that follow.
- 4) Make checks as indicated. (See the tables on pp. 10-5 ff.)

b. Using Service Mode

• Without the Reader Unit Installed (with the printer board installed)

- 1) Connect the power plug to the power outlet; and while holding on the "Menu key, Enter/Online key, and Cancel key" on the control panel at the same time until "Start SELF-TEST" displays. The panel displays will show "Display" to indicate that service mode has started after the printer unit checks itself.
 - 2) Using the Menu key on the control panel, select "SENSOR MONITOR".
 - 3) Press the ENTER key to select "SENSOR MONITORING".
 - 4) Check to make sure that "SENSOR MONITORING" has appeared on the first row of the display, indicating that at the mode in question has been selected.
 - 5) Turn on the sensor in question manually so that the result of monitoring will appear on the second row of the display.
- The result of monitoring is indicated by means of a hexadecimal code (2 digits; either xx or yy group).

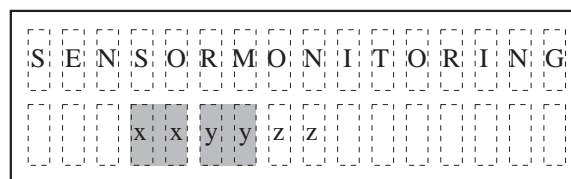

Figure 10-101 Control Panel of the Printer Unit

Note:

1. The notation "zz" shown on the display (2nd row) is for use at the factory for checks and is not relevant to servicing work.
2. Each sensor has its own response time, some requiring as much as about 5 sec. Be sure to allow an adequate period of time before making a decision on each sensor.
3. If multiple sensors are turned on at the same time, the result will be the sum of the codes obtained for all sensors (in hexadecimal notation).
4. To execute sensor monitor mode, be sure to remove the intermediate transfer drum, all cartridges, and secondary transfer belt assembly before starting service mode. (Otherwise, you could inadvertently touch operating parts.)

Further, you need to remove the following parts for respective sensors in view of the type of work to perform:

- For PS1903 and PS5, the fixing assembly.
- For PS11, the upper cover assembly.
- For PS1207, the cassette 1.
- For PS1208, the cassette 2.

• With the Reader Unit Installed

- 1) Start service mode.
- 2) Select COPIER>I/O>DC-CON or R-CON in sequence to bring up the screen shown in Figure 10-102.
- 3) Make checks as shown. (See pp. 10-5 ff.)

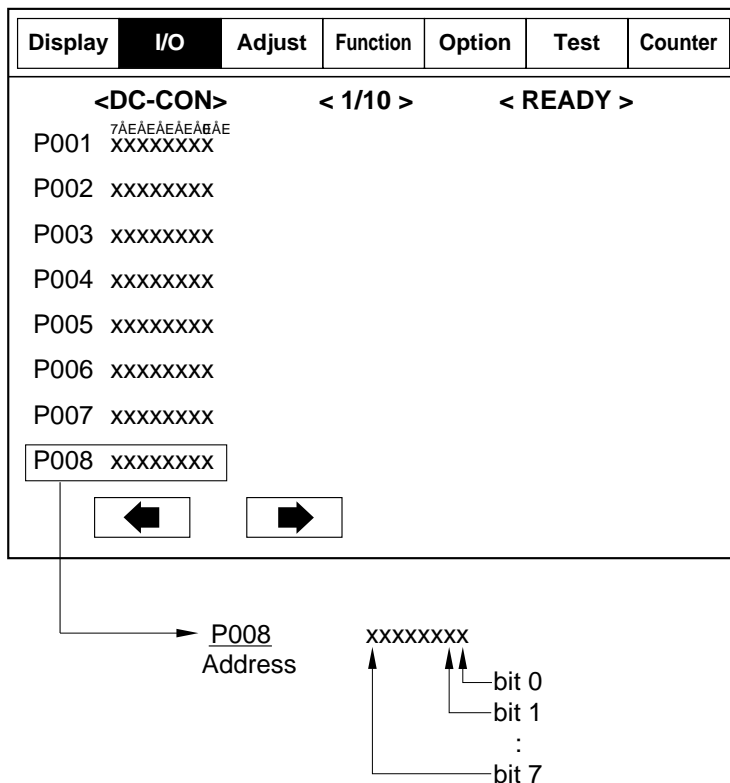

Figure 10-102

No.		PS1	PS3 *1	PS5
Name		Registration paper sensor	Developing rotary position sensor	Separation sensor
Meter probe (+)		J212-10	J207-5	J212-7
Service mode	Printer unit panel	01 (display reading), xx (display position)	/	C4 (display reading), xx (display position)
	Reader unit panel	DC-CON, P001 bit 0		DC-CON, P001 bit 2
Checks (normal as described)		While in standby, when the detecting lever is <ul style="list-style-type: none"> • pushed down, '0'. • not pushed down, '1'. 	While in standby, press the turret button to turn the color cartridge. When the color cartridge is <ul style="list-style-type: none"> • at rest (Y), '1'. • otherwise, '0'. 	While in standby, when the detecting lever is <ul style="list-style-type: none"> • pushed down, '0'. • not pushed down, '1'.

No.		PS10	PS11	PS17
Name		Face-down tray full sensor	Face-down try delivery sensor	Pick-up assembly paper sensor
Meter probe (+)		J220-A3	J207-5	J210-8
Service mode	Printer unit panel	/	10 (display reading), xx (display position)	02 (display reading), xx (display position)
	Reader unit panel		DC-CON, P001 bit 4	DC-CON, P001 bit 1
Checks (normal as described)		While in standby, when the light-blocking plate is <ul style="list-style-type: none"> • moved to PS10, '1'. 	While in standby, the light-blocking plate is <ul style="list-style-type: none"> • moved to PS11, '1'. 	While in standby, paper is <ul style="list-style-type: none"> • put over PS17, '0'.

No.		PS18	PS19 *1	PS23
Name		Pick-up unit cover sensor	Multifeeder tray last sheet sensor	Duplexing feeding roller 1 home position sensor
Meter probe (+)		J210-16	J208-3	J2007-6 *2
Service mode	Printer unit panel			
	Reader unit panel		DC-CON, P002 bit 0	
Checks (normal as described)		While in standby, the pick-up unit cover is <ul style="list-style-type: none"> • opened, '0'. • closed, '1'. 	While in standby, when the roll under PS19 is rotated, alternately '0' and '1'.	While in standby, remove the duplexing unit, and move the light-blocking plate to the sensor, and put the duplexing unit back in. When the light-blocking plate is <ul style="list-style-type: none"> • moved over the sensor, '1'. • not moved over the sensor, '0'.

No.		PS24	PS25	PS26
Name		Duplexing unit paper sensor	Horizontal registration guide home position sensor	Reversal paper sensor
Meter probe (+)		J2008-3 *2	J2006-3 *2	J2007-3 *2
Service mode	Printer unit panel			
	Reader unit panel	DC-CON, P002 bit 4		DC-CON, P002 bit 5
Checks (normal as described)		While in standby, when paper is <ul style="list-style-type: none"> • put over PS24, '0'. 	While in standby, remove the duplexing unit, and move the light-blocking plate to the sensor, and put the duplexing unit back in. When the light-blocking plate is <ul style="list-style-type: none"> • moved over the sensor, '1'. • not moved over the sensor, '0'. 	While in standby, when paper <ul style="list-style-type: none"> • is put over PS26, '0'.

No.		PS30	PS1201	PS1202
Name		Upper left cover sensor	Cassette 2 sensor	Cassette 1 sensor
Meter probe (+)		J220-A4	J210-10	J210-6
Service mode	Printer unit panel			
	Reader unit panel			
Checks (normal as described)		While in standby, when the upper cover is <ul style="list-style-type: none"> • opened, '0'. • closed, '1'. 	While in standby, when the cassette 2 is <ul style="list-style-type: none"> • slid out, '0'. • slid in, '1' 	While in standby, when the cassette 1 is <ul style="list-style-type: none"> • slid out, '0'. • slid in, '1'.

No.		PS1203	PS1204
Name		Cassette 2 paper level sensor 2	Cassette 2 paper levels sensor 1
Meter probe (+)		J210-12	J210-13
Service mode	Printer unit panel		
	Reader unit panel		
Checks (normal as described)		While in standby, put one sheet of paper in the cassette 2. When the cassette is slid in, <ul style="list-style-type: none"> • J210-12 is '0', and J210-13 is '1'. Put about 100 sheets of paper. When the cassette is slid in, <ul style="list-style-type: none"> • J210-12 is '1', and J210-13 is '1'. Put about 500 sheets of paper. When the cassette is slid in, <ul style="list-style-type: none"> • J210-12 is '0', and J21013 is '0'. 	

No.		PS1205	PS1206	PS1207
Name		Cassette 1 paper level sensor 2	Cassette 1 paper level sensor 1	Cassette 2 paper absent sensor
Meter probe (+)		J210-14	J210-15	J210-11
Service mode	Printer unit panel			08 (display reading), yy (display position)
	Reader unit panel			DC-CON, P002 bit 3
Checks (normal as described)		<p>While in standby, put one sheet of print paper in the cassette. When the cassette is slid in,</p> <ul style="list-style-type: none"> • J210-14 is '0', and J210-15 is '1'. <p>Put about 100 sheets of paper. When the cassette is slid in,</p> <ul style="list-style-type: none"> • J210-14 is '1', and J210-15 is '1'. <p>Put about 500 sheets of paper. When the cassette is slid in,</p> <ul style="list-style-type: none"> • J210-14 is '0', and J210-15 is '0'. 		<p>While in standby, when the cassette 2</p> <ul style="list-style-type: none"> • contains paper, '0'. • does not contain paper, '1'.

No.		PS1208	PS1301	PS1302 *1
Name		Cassette 1 paper absent sensor	Multifeeder tray paper sensor	Holding plate position sensor
Meter probe (+)		J210-5	J213-7	J213-6
Service mode	Printer unit panel	02 (display reading), yy (display position)	01 (display reading), yy (display position)	
	Reader unit panel	DC-CON, P002 bit 1		
Checks (normal as described)		<p>While in standby, when the cassette 1</p> <ul style="list-style-type: none"> • contains paper, '0'. • does not contain paper, '1'. 	<p>While in standby, when the multifeeder</p> <ul style="list-style-type: none"> • contains paper, '0'. • does not contain paper, '1'. 	<p>While in standby, when the light-blocking plate is moved over PS1302, '0'.</p> <p>(The cam gear is turned on to lower the holding plate.)</p>

No.	PS1903	
Name	Fixing delivery sensor	
Meter probe (+)	J207-12	
Service mode	Printer unit panel	/
	Reader unit panel	
Checks (normal as described)	<p>While in standby, the white lever over the fixing delivery sensor is</p> <ul style="list-style-type: none"> • pushed, '1'. • not pushed, '0'. <p>Note that this sensor is a photosensor.</p>	

*1: Open the right cover, and use the door switch actuator.

*2: Found on the duplexing driver PCB.

II. TROUBLESHOOTING IMAGE FAULTS

A. Making Initial Checks

1. Site Environment

- a. The voltage must be as rated ($\pm 10\%$).
- b. The machine must not be in a high-temperature/-humidity environment (near water faucet, water boiler, humidifier), or it must not be in a cold place. There must not be a source of fire nearby, and the machine must not be subjected to excess dust.
- c. The machine must not be subjected to ammonium gas.
- d. The machine must not be exposed to direct sunshine. As necessary, curtains must be provided.
- e. The room must be well ventilated.
- f. The machine must be kept level.
- g. The power plug of the printer unit must be connected to the power outlet. However, if the reader unit is installed, the power plug of the printer unit must be connected to the reader unit and the power plug of the reader unit must be connected to the power outlet.

2. Checking the Originals

Check the problem to find out whether it is caused by the original or the machine.

a. Checking the Density of the Original

A diazo original or an original with a high transparency can produce prints that can be mistakenly thought of as being "foggy."

An original prepared in light pencil can produce prints that can be mistakenly thought of as being "too light."

3. Checking the Assemblies

- a. Check the secondary pre-transfer charging assembly and the separation static eliminator for dirt and faults (scratches, deformations).
- b. Clean the cleaning wires of the secondary pre-transfer charging assembly and the separation static eliminator. Also, clean the density sensor and the pre-exposure LED assembly.
- c. Check to make sure that the following are mounted properly: intermediate transfer drum unit, fixing assembly, ITD cleaning roller, secondary transfer belt assembly, toner cartridge, and drum cartridge.

4. Checking the Paper

- a. Is the paper of a type recommended by Canon?
- b. Is the paper moist? Try paper fresh out of package.

5. Placement of Print Paper

- a. Print paper must be placed in the cassette or the multifeeder tray in an appropriate volume and in correct orientation.
- b. Transparencies must be placed on the multifeeder tray in the correct orientation.

6. Checking the Durable Parts

- a. Check with the consumables table, and replace parts that reached the end of their lives.

7. Others

In winter, bringing a machine from a cold to warm place can cause condensation inside it, leading to various problems.

- a. Condensation in the original exposure system or the drum exposure system (6-facet mirror, reflecting mirror, lens) can produce light images.
- b. Condensation in the charging system can cause leakage.
- c. Condensation on the pick-up/feeding guide can cause feeding faults.
- d. When cold, the photo-conducting layer of the photosensitive drum inside the drum cartridge tends to have a high resistance, causing poor contrast on prints.
- e. Condensation on the surface of the intermediate transfer drum can cause ITD cleaning faults.

If condensation is found, dry wipe the parts, or leave the machine powered for 10 to 20 min. Opening a toner cartridge immediately after bringing it in from a cold place will also cause condensation. Instruct the user to make sure that the cartridges have become used to the room temperature by leaving them alone (for 1 to 2 hr) before opening them.

Note:

If the reader unit is installed, it is important to find out whether the cause of the image fault, if any, is in the reader unit or the printer unit.

- If the problem occurs when the CA-1 Chart is copied but does not occur on a test print generated in service mode using the reader unit,
 - the cause is in the reader unit. (See the Reader Unit Service Manual.)
- If the problem occurs on the test print generated in service mode using the reader unit.
 - the cause is in the printer unit. (See the pages that follow.)

B. Guide to Test Prints for the Printer Unit

The printer unit contains the test print patterns (horizontal lines) of four colors (yellow, magenta, cyan, and black) shown in Figure 10-202. Generate test prints if a problem occurs in the printer unit to find out its cause.

To generate a test print without a printer board, turn on the power while holding down the Test Print switch. Then, press the switch when the printer unit has entered standby state.

To generate a test print with the printer board installed, turn on the power, and press the switch when the machine has entered standby state.

Do not turn on the power while holding down the switch if the printer board is installed. The display panel will indicate "Service Call," and the printer unit will enter an error state. Be sure to turn on the power as normally done if the printer board is installed.

If the display panel indicates "Service call," turn off and then on the power effort generating a test print.

When generating test prints, the machine uses the cassette 2. Make sure that the cassette 2 contains paper before pressing the switch.

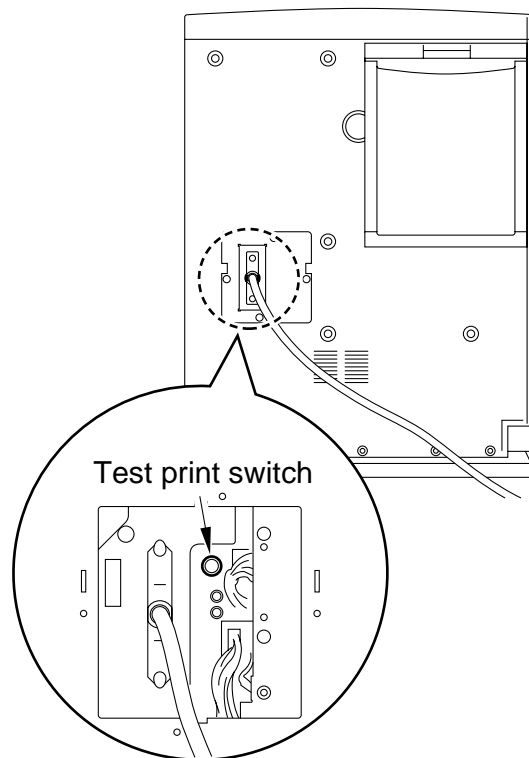

Figure 1-201

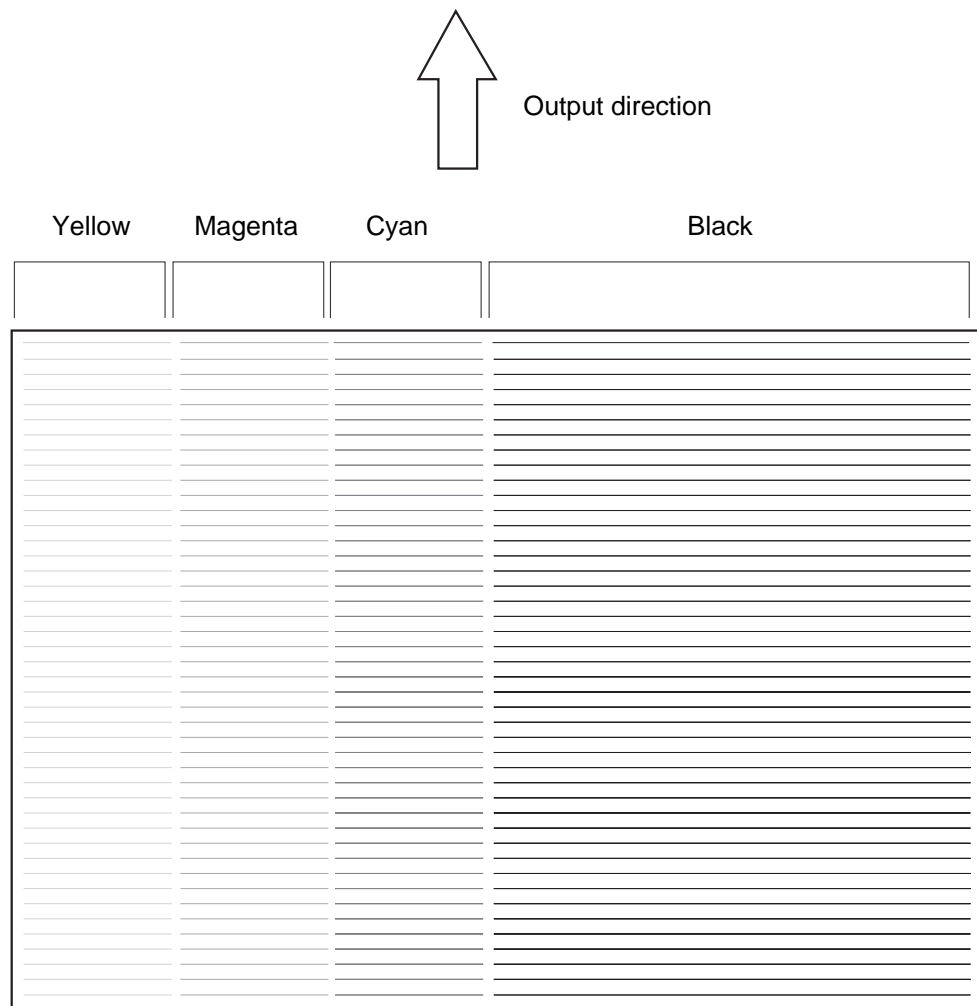

Figure 10-202

Reference:

If the reader unit is installed, you may use its control panel to select COPIER>TEST>PG>TYPE to generate test prints (16 types), i.e., thereby generating common color copier test prints (16 type).

C. Troubleshooting Image Faults

No.	Item	Remarks	Page
1	Light	The output image is undoubtedly too light.	10-15
2	Dark	The output image is undoubtedly too dark.	10-17
3	Blank	The printer unit fails to generate images.	10-17
4	Solid black/solid color	The printer unit generates a solid black or an image in solid color.	10-18
5	Soiled image/soiled back	The face/back of print paper is soiled.	10-19
6	Vertical band/vertical line (sub scanning direction)	The print has vertical lines (sub scanning direction).	10-22
7	White bands/white lines (vertical; sub scanning direction)	The print has white vertical lines (sub scanning direction).	10-22
8	Horizontal bands/horizontal lines (main scanning direction)	The print has vertical lines (main scanning direction).	10-23
9	White bands/white lines (horizontal; main scanning direction)	The print has white vertical lines (main scanning direction).	10-23
10	Absence of specific color	The print has a missing color (specific color).	10-23
11	White spot	The print has white spots.	10-24
12	Fixing fault	The print has an inadequately fused toner image.	10-24
13	Distorted image/displaced color	The print has a distorted or color-displaced image.	10-25
14	Uneven image	The print has smudged or uneven image.	10-26
15	Dots	The print has an image with dots.	10-27
16	Ghost	The print has a (positive) ghost image.	10-27
17	Soiling (double-sided print)	The face/back of print paper is soiled (when made in double-sided printing mode).	10-27

Table 10-201

1	The print is too light.
----------	--------------------------------

Cause	Step	Checks	Yes/No	Action
/	1	Make a test print in service mode (TEST>PG>TYPE=14), and find the color that is light on the print. Is the color on the test print?	YES	If the problem is black only, go to step 2. If the problem is three colors, go to step 7. If the problem is all four colors, go to step 9. If the problem is one color, go to step 7.
Black toner cartridge	2	Is the contact of the black toner cartridge (for black developing bias) or the contact for black developing bias of the printer unit soiled?	YES	Clean the contact. If it is deformed, replace the problem part. Also, check for a displaced contact.
High-voltage PCB 1 (inadequate black developing bias output)	3	Open the front cover while black toner is being developed on the photosensitive drum (about 30 sec after the start of test printing), and take out the black toner cartridge. Then, take out the black toner cartridge, and check the toner image on the photosensitive drum. Is the black toner image fully developed on the surface of the photosensitive drum?	NO	Replace the high-voltage PCB 1.
Secondary pre-transfer charging assembly	4	Is the charging wire of the secondary pre-transfer charging assembly inside the intermediate transfer drum unit broken?	YES	Replace the secondary pre-transfer charging assembly.
Intermediate transfer drum unit	5	Is the contact of the intermediate transfer drum unit (for secondary pre-transfer charging bias) or the contact for the secondary pre-transfer charging bias of the printer unit soiled?	YES	Clean the contact. If it is soiled or damaged, replace the problem part. Also, check for a displaced contact.
High-voltage PCB 2 (inadequate pre-transfer charging bias output)	6	Replace the high-voltage PCB. Is the problem corrected?	NO	Replace the DC controller PCB.
			YES	End.

Cause	Step	Checks	Yes/No	Action
Contact (for color developing bias)	7	Is the contact for the color developing bias for the printer unit soiled?	YES	Clean the contact. If it is deformed or damaged, replace the problem part. Also, check for a displaced contact.
High-voltage PCB 1 (inadequate color developing bias output)	8	Open the front cover while toner is being developed on the photosensitive drum (about 20 sec after the start of test printing), and take out the black toner cartridge. Then, take out the drum cartridge, and check the toner image on the surface of the photosensitive drum. Is the color toner image fully developed on the surface of the photosensitive drum?	NO	Replace the high-voltage PCB 1.
			YES	Replace the DC controller PCB.
	9	Open the right cover of the printer unit, and fit the door switch actuator. Make a print, and check the toner image on the surface of the intermediate transfer drum. Is the toner image fully developed on the surface of the intermediate transfer drum?	NO	Go to step 10.
			YES	Go to step 12.
Intermediate transfer drum	10	Is the contact of the intermediate transfer drum unit (for primary transfer bias) or the contact of the primary transfer bias for the printer unit soiled?	YES	Clean the contact. If it is deformed or damaged, replace the problem part. Also, check for a displaced contact.
High-voltage PCB 1 (inadequate primary transfer bias output)	11	Replace the high-voltage PCB 1. Is the problem corrected?	YES	End.
			NO	Go to step 12.
Secondary transfer belt assembly	12	Is the contact of the secondary transfer belt assembly (for secondary transfer bias) or the contact of the secondary transfer bias for the printer unit soiled?	YES	Clean the contact. If it is deformed or damaged, replace the problem part. also, check for a displaced contact.
High-voltage PCB 2	13	Replace the high-voltage PCB 2. Is the problem corrected?	YES	End.
			NO	Replace the DC controller PCB.

2 The print is too dark.

Cause	Step	Checks	Yes/No	Action
Density sensor	1	Is the lens of the density sensor soiled?	YES	Clean the lens with a special brush.
Grounding wire contact (drum cartridge)	2	Is the contact of the grounding wire of the drum cartridge or the contact of the drum grounding wire for the printer unit soiled?	YES	Clean the contact. If it is deformed or damaged, replace the problem part. Also, check for a displaced contact.
Contact (drum cartridge; for primary charging bias)	3	Is the contact of the drum cartridge (for primary charging bias) or the contact for primary charging of the printer unit soiled?	YES	Clean the contact. If it is deformed or damaged, replace the problem part. Also, check for a displaced contact.
High-voltage PCB 1 (primary charging bias output)	4	Replace the high-voltage PCB 1. Is the problem corrected?	YES	End.
			NO	Replace the DC controller PCB.

3 The print is blank.

Cause	Step	Checks	Yes/No	Action
Laser shutter	1	Is the boss for opening/closing the laser shutter on the front cover or the right cover of the printer unit damaged?	YES	Replace the front cover or the right cover.
	2	Does the laser shutter arm and the laser shutter move smoothly?	NO	Replace the problem part.
High-voltage PCB 1	3	Are the connectors J5001 and J226 on the high-voltage PCB 1 connected securely?	NO	Connect them securely.
High-voltage PCB 1 (no color/black developing bias output)	4	Replace the high-voltage PCB 1. Is the problem corrected?	YES	Replace the high-voltage PCB 1.

Cause	Step	Checks	Yes/No	Action
Connector (cartridge motor drive)	5	Are the connectors J5001 and J5003 on the high-voltage PCB 1 and the connector J226 on the DC controller PCB connected securely?	NO	Connect them securely.
Cartridge motor (M3)	6	Turn on the reader unit rear power switch and the control panel power soft switch. Is the voltage between the connector J5003-1 (+24 UH) on the high-voltage PCB 1 and the nearby GND 24 V?	YES	Replace the cartridge motor.
High-voltage PCB 1	7	Replace the high-voltage PCB 1. Is the problem corrected?	YES	End.
DC controller PCB			NO	Replace the DC controller PCB.

4 The print is solid black/solid color.

Cause	Step	Checks	Yes/No	Action
Drum cartridge	1	Is the contact of the drum cartridge (for primary charging bias) or the contact for primary charging of the printer unit soiled?	YES	Clean the contact. If it is deformed or damaged, replace the problem part. Also, check for a displaced contact.
	2	Replace the drum cartridge (primary charging roller). Is the problem corrected?	YES	Replace the drum cartridge.
High-voltage PCB 1 (for primary charging bias)	3	Replace the high-voltage PCB 1. Is the problem corrected?	YES	End.
			NO	Replace the DC controller PCB.

5	The print has a soiled image/soiled back.
----------	--

Cause	Step	Checks	Yes/No	Action
Cassette pick-up roller, Registration roller, Lower fixing roller, Feeding roller 1/, Etc.	1	Does the soiling have a specific interval (as of the diameter of the cassette pick-up roller, registration roller, lower fixing roller, feeding roller 1/2, etc.)?	YES	See Table 10-202. Identify the soiled roller, and clean it. If the dirt cannot be removed, replace it.
Secondary transfer belt assembly, Fixing inlet guide, Fixing/separation lower guide, Separation guide	2	Is the secondary transfer belt assembly, fixing assembly inlet guide, fixing/separation lower guide or separation guide soiled?	YES	Clean the soiled part. If the dirt cannot be removed, replace the part.
ITD cleaning	3	Are there scratches or dirt in the peripheral direction of the ITD cleaning roller?	YES	Replace the ITD cleaning roller.
	4	Is the contact of the ITD cleaning roller (for ITD cleaning bias) or the contact for the ITD cleaning mechanism of the printer unit soiled?	YES	Clean the contact. If it is damaged, replace the problem part. Also, check for a displaced part.
	5	Does the problem occur in a high humidity environment?	YES	Wipe the surface of the intermediate transfer drum with a moistened flannel cloth; then, dry wipe it with lint-free paper.
Fixing assembly	6	Is the contact of the fixing assembly (for fixing bias) or the contact for the fixing/separation bias of the printer unit soiled?	YES	Clean the contact. If it is damaged, replace the problem part. Also, check for a displaced contact.
High-voltage PCB 2 (ITD cleaning bias or fixing/separation bias output absent)	7	Replace the high-voltage PCB 2. Is the problem corrected?	YES	Replace the PCB.

Cause	Step	Checks	Yes/No	Action
ITD cleaning roller drive assembly	8	Is the drive gear or the like used to transmit locking/unlocking drive of the ITD cleaning roller worn or cracked?	YES	Replace the worn or cracking part.
	9	Is the cam used to lock/unlock the ITD cleaning roller worn or cracked?	YES	Replace the worn or cracking part.
ITD cleaning roller locking/unlocking solenoid (SL1)	10	Are the connector J674 on the sub relay PCB and the connector J227 on the DC controller PCB connected securely?	NO	Connect the connectors securely.
	11	Disconnect the connector J674 of the solenoid, and measure the voltage between the connectors J674-1 (CLNRON) and J674-2 (+24 UH) on the harness side. Is it about 85 ?	NO	Replace the ITD cleaning roller locking/unlocking (SL21) solenoid.
DC controller PCB	12		YES	Replace the DC controller PCB.

Problem part	Diameter* (mm)	Image interval* (mm)	Development			
			Soiling	White spot	Soiled back	Faulty fixing
Cassette pick-up roller	24	75			✓	
Separation roller	24	75	✓			
Feeding roller 1	24	75			✓	
Feeding roller 2	38	119			✓	
Multifeeder pick-up roller	30	94	✓			
Registration roller	16	52	✓		✓	
Primary charging roller	14	44		✓		
Photosensitive drum	62	195	✓	✓		
Developing cylinder	21	66	✓			
Upper fixing roller	46	144	✓			✓
Lower fixing roller	46	144			✓	✓
ITD cleaning roller	18	57	✓			

*Approximate.

Table 10-202

6 The print has vertical bands/lines (sub scanning direction).

Cause	Step	Checks	Yes/No	Action
Photosensitive drum	1	Are there scratches in the peripheral direction (sub scanning direction) of the photosensitive drum?	YES	Replace the photosensitive drum cartridge.
Upper fixing roller	2	Are there scratches in the peripheral direction (sub scanning direction) of the upper fixing roller?	YES	Replace the upper fixing roller.

7 The print has white bands/lines (vertical; sub scanning direction).

Cause	Step	Checks	Yes/No	Action
	1	Make a vertical stripe test print (TYPE=10). Do the white bands/lines occur in a specific color only?	YES	Replace the toner cartridge of the color.
Fixing/separation upper guide	2	Is the fixing/separation upper guide coated with toner?	YES	Clean the fixing/separation upper guide.
Photosensitive drum unit	3	Are there scratches in the peripheral direction (sub scanning direction) of the photosensitive drum?	YES	Replace the photosensitive drum cartridge.
Laser optical path	4	Is the laser emission opening of the printer unit coated with foreign matter?	YES	Remove the foreign matter.
Printer unit laser scanner/scanner assembly	5	Is any of the mirrors of the laser/scanner assembly soiled?	YES	Replace the laser/scanner assembly.
Intermediate transfer drum unit	6	Are there scratches in the peripheral direction (sub scanning direction) of the intermediate transfer drum?	YES	Replace the intermediate transfer drum unit.
Upper fixing roller	7	Are there scratches in the vertical direction (sub scanning direction) of the upper fixing roller?	YES	Replace the upper fixing roller.

8 The print has horizontal bands/lines (main scanning direction).

Cause	Step	Checks	Yes/No	Action
Photosensitive unit	1	Are there scratches in the horizontal direction (main scanning direction) of the photosensitive drum?	YES	Replace the photosensitive drum cartridge.
Upper fixing roller	2	Are there scratches in the horizontal direction (main scanning direction) of the upper fixing roller?	YES	Replace the upper fixing roller.

9 The print has white bands/lines (horizontal; main scanning direction).

Cause	Step	Checks	Yes/No	Action
Photosensitive unit	1	Are there scratches in the horizontal direction (main scanning direction) of the photosensitive drum?	YES	Replace the photosensitive drum.
Intermediate transfer drum unit	2	Are there scratches in the horizontal direction (main scanning direction) of the intermediate transfer drum?	YES	Replace the intermediate transfer drum unit.

10 The print has a missing color (specific).

Cause	Step	Checks	Yes/No	Action
Toner cartridge	1	Remove the toner cartridge, and turn on the power. If the printer unit starts up normally, check each of the toner cartridges in question. Is it faulty?	YES	Replace the problem cartridge.
Toner level detection	2	Is the missing color black?	YES	See IV.B.19. "The black toner cartridge is empty."
			NO	See IV.B.17. "The color toner cartridge is empty."

11 The print has white spots.

Cause	Step	Checks	Yes/No	Action
Toner cartridge	1	Does any of the developing cylinders of the toner cartridge have a fault?	YES	Replace the problem cartridge.
Photosensitive drum unit	2	Does the photosensitive drum or the primary charging roller have a fault?	YES	Replace the photosensitive drum cartridge.
Secondary transfer belt assembly	3	Does the unlocking mechanism of the secondary transfer belt assembly have a fault?	YES	Replace the problem part.
Intermediate transfer drum unit	4	Is the intermediate transfer drum unit deformed or is soiled with oil?	YES	Replace the intermediate transfer drum unit.
Secondary transfer belt assembly	5	Is the contact of the secondary transfer belt assembly (for secondary transfer bias) or the contact for secondary transfer bias of the printer unit soiled?	YES	Clean the contact. If it is deformed or damaged, replace the problem part. Also, check for a displaced contact.
High-voltage PCB 2 (inadequate transfer bias output)	6	Replace the high-voltage PCB 2. Is the problem corrected?	YES	Replace the high-voltage PCB 2.
DC controller PCB	7		YES	Replace the DC controller PCB.

Note: See Table 10-202.

12 The print has poor fixing.

Cause	Step	Checks	Yes/No	Action
Fixing assembly	1	Is the upper/lower fixing roller scratched or deformed?	YES	Replace the upper/lower fixing roller or the fixing assembly.
	2	Is the upper/lower fixing thermistor soiled?	YES	Clean the upper/lower fixing thermistor.
DC controller PCB	3		NO	Replace the DC controller PCB.

Note: See Table 10-202.

13 The print has a distorted image/displaced color.

Cause	Step	Checks	Yes/No	Action
Drum motor drive assembly	1	Is the drive gear between the drum cartridge and the drum motor or between the intermediate transfer drum and the drum motor worn/cracked?	YES	Replace the worn/cracking gear.
Laser/scanner assembly	2	Are the connectors J1001, J2, and J901 of the laser/scanner assembly connected securely?	NO	Connect them securely.
	3	Replace the laser/scanner assembly. Is the problem corrected?	YES	Replace them.
DC controller PCB	4	Are the connectors J205 and J211 on the DC controller PCB connected securely?	NO	Connect them securely.
			YES	Replace the DC controller PCB.

14 The print has an uneven image.

Cause	Step	Checks	Yes/No	Action
Separation sensor	1	Is the movement of the lever of the separation sensor poor?	YES	Replace the sensor lever.
Fixing assembly	2	Is the fixing assembly inlet guide soiled? Or, is the contact of the upper fixing roller (for fixing/separation bias) or the contact for fixing/separation bias of the printer unit soiled?	YES	Clean the contact. If it is deformed or damaged, replace it. Also, check for a displaced contact.
High-voltage PCB 2	3	Are the connectors J5005 and J5006 on the high-voltage PCB 2 connected securely?	NO	Connect them securely.
	4	Replace the high-voltage PCB 2. Is the problem corrected?	YES	Replace the high-voltage PCB 2.
Fixing assembly	5	Is the upper fixing cover fitted to the fixing assembly securely?	NO	Fit the cover securely.
Registration roller, Feeding roller 2	6	Is the drive gear of the registration roller or the feeding roller worn?	YES	Replace the worn gear.
Separation static eliminator	7	Is the charging wire of the separation static eliminator broken?	YES	Replace the separation static eliminator.
Separation static eliminating bias PCB	8	Are the connectors J5600, J5601, and J5602 on the separation static eliminating bias PCB connected securely?	NO	Connect them securely.
	DC controller PCB	9	Replace the separation static eliminator PCB. Is the problem corrected?	YES
			NO	Replace the DC controller PCB.

15 The print has dots.

Cause	Step	Checks	Yes/No	Action
Secondary transfer belt assembly	1	Is the charging roller of the secondary transfer belt deformed or worn?	YES	Replace the secondary transfer charging roller.
Separation static eliminator	2	Is the charging wire of the separation static eliminator broken?	YES	Replace the separation static eliminator.
Separation static eliminator bias PCB	3	Are the connectors J5600, J5601, and J5602 on the separation static eliminating bias PCB connected securely?	NO	Connect them securely.
	4	Replace the separation static eliminating bias PCB. Is the problem corrected?	YES	End.
NO			Replace the DC controller PCB.	

16 The print has a ghost image.

Cause	Step	Checks	Yes/No	Action
Connector, Wiring	1	Are the connector J681 of the pre-exposure LED assembly, relay connectors J74 and J18, connectors J645 and J647 on the main relay PCB, and connector J227 on the DC controller PCB connected securely?	NO	Connect them securely.
Pre-exposure LED assembly	2	Replace the pre-exposure LED assembly. Is the problem corrected?	YES	Replace the pre-exposure LED assembly.
DC controller PCB			NO	Replace the DC controller PCB.

17 The print is soiled (in double-sided copying mode).

Cause	Step	Checks	Yes/No	Action
Duplexing unit	1	Is the duplexing feeding roller 1 soiled?	YES	Clean the roller.
	2	Is the feeding guide soiled?	YES	Clean the guide.
	3	Is the reversing roller or the duplexing feeding roller 2 soiled?	YES	Clean the roller.
NO			Replace the duplexing unit.	

III. TROUBLESHOOTING MALFUNCTIONS

Caution:

1. If you must measure the voltage using the indicated terminals of a connector, be sure to check the connector for poor contact.
2. When handling PCBs, be sure to touch a metal area of the printer unit before starting the work to discharge the build-up of static electricity, thereby preventing damage to the PCBs.
3. When replacing the DC controller PCB, see p. 10-1.
4. The machine's scanner/laser assembly and the intermediate transfer drum (ITD) cannot be adjusted in the field. Do not try to disassemble it. (The secondary pre-transfer charging assembly inside the intermediate transfer drum, however, may be replaced on its own.)

A. Error Codes

No.	Item	Page	No.	Item	Page
1	E000/E003	10-30	16	E196/E197/E198	10-39
2	E001	10-31	17	E240	10-39
3	E004	10-31	18	E677/E678/E679	10-40
4	E009	10-32	19	E805	10-40
5	E010/E011	10-32	20	E806	10-41
6	E013	10-32	21	E807	10-42
7	E019	10-33	22	E808	10-42
8	E020	10-33	23	E810	10-43
9	E021	10-34	24	E812	10-43
10	E040	10-35	25	E813	10-43
11	E054	10-36	26	E814	10-44
12	E055	10-37	27	E545/E546	10-44
13	E066	10-38	28	E903	10-44
14	E100	10-38	29	Service Call Check Reader	10-44
15	E110	10-39	30	Others	10-44

1	E000/E003
----------	------------------

Cause	Step	Checks	Yes/No	Action
Upper thermistor (open circuit)	1	Remove the fixing assembly, and measure the resistance between the connectors J26F-A4 (FXTHU) and J26F-A3 (GND) on the fixing assembly side. Is it between 250 K and 600 K (normal temperature)?	NO	Check the wiring from the connector J222 on the DC controller PCB to the upper thermistor; if normal, replace the upper thermistor.
Lower thermistor (open circuit)	2	Measure the resistance between the connectors J26F-A2 (FXTHL) and J26F-A1 (GND) on the fixing assembly side. Is it between 250 K and 600 K (normal temperature)?	NO	Check the wiring from the connector J222 on the DC controller PCB to the lower thermistor; if normal, replace the lower thermistor.
Upper fixing heater, Upper thermal switch (open circuit)	3	With the fixing assembly removed, is there electrical continuity between the connectors J27F-3 (HTUH) and J27F-4 (HTUC) on the fixing assembly side?	NO	Check the upper fixing heater and the thermal switch. Replace any problem parts.
Lower fixing heater, Lower thermal switch (open circuit)	4	Is there electrical continuity between the connectors J26F-3 (HTLH) and J26F-4 (HTLC) on the fixing assembly side?	NO	Check the lower fixing heater and the lower thermal switch. Replace any problem parts.
Upper/Lower thermistor	5	Is the upper/lower thermistor in even contact with the upper/lower fixing roller?	NO	Mount the thermistor properly.
Upper/lower thermistor	6	Mount the thermistor properly.	YES	Clean the area of contact with the upper/lower fixing roller.
Connector	7	Are the connector J222 on the DC controller PCB and the connector J26 of the fixing assembly connected securely?	NO	Connect the connectors securely.
Power supply (printer unit)	8	Replace the power supply of the printer unit. Is the problem corrected?	YES	End.
			NO	Replace the DC control PCB.

Caution:

If E001 or E003 is indicated, be sure to discharge the error memory capacitor (C259) on the DC controller PCB after troubleshooting the problem, as it may contain error memory. (Short JP201 on the DC controller PCB to discharge C259.)

2	E001
----------	-------------

Cause	Step	Checks	Yes/No	Action
Upper thermistor (short circuit)	1	With the fixing assembly removed, measure the resistance between the connectors J26F-A4 (FXTHU) and J26F-A3 (GND) on the fixing assembly side. Is it 2 K or less?	YES	Check the wiring from the connector J222 on the DC controller PCB to the upper thermistor; if normal, replace the upper thermistor.
Lower thermistor (short circuit)	2	Measure the resistance between the connectors J26F-A2 (FXTHL) and J26F-A1 (GND) on the fixing assembly side. Is it 2 K or less?	YES	Check the wiring from the connector J222 on the DC controller PCB to the lower thermistor; if normal, replace the lower thermistor.
Power supply (printer unit)	3	Replace the power supply unit of the printer unit. Is the problem corrected?	YES	End.
			NO	Replace the DC controller PCB.

Caution:

If E001 or E003 is indicated, be sure to discharge the error memory capacitor (C259) on the DC controller PCB after troubleshooting the problem, as it may contain error memory. (Short JP201 on the DC controller PCB to discharge C259.)

3	E004
----------	-------------

Cause	Step	Checks	Yes/No	Action
Upper fixing heater/Upper thermal switch (open circuit)	1	With the fixing assembly removed, is there electrical continuity between the connectors J27F-3 (HTUH) and J27F-4 (HTUC) on the fixing assembly side?	NO	Check the upper fixing heater and the upper thermal switch. Replace the problem parts.
Lower fixing heater, Lower thermal switch (open circuit)	2	Is there electrical continuity between the connectors J26F-3 (HTLH) and J26F-4 (HTLC) on the fixing assembly side?	NO	Check the lower fixing heater and the lower thermal switch. Replace the problem parts.
Connectors	3	Are the connector J222 on the DC controller PCB, connector J26 of the fixing assembly, and connector J101 of the printer unit power supply connected securely?	NO	Connect the connectors securely.
Power supply (printer unit)	4	Replace the power supply of the printer unit. Is the problem corrected?	YES	End.
			NO	Replace the DC controller PCB.

4 E009

Cause	Step	Checks	Yes/No	Action
Fixing assembly	1	Does the rated voltage of the fixing assembly match the machine's voltage?	NO	Check the parts number; if necessary, replace the fixing assembly or the printer unit power supply.
Connectors	2	Are the connectors J222 on the DC controller PCB and the connectors J26 of the fixing assembly connected securely?	NO	Connect the connectors.
			YES	Replace the DC controller PCB.

5 E010/E011

Cause	Step	Checks	Yes/No	Action
Connector	1	Are the connector J219 on the DC controller PCB and the relay connector J1 connected securely?	NO	Connect the connectors securely.
Main motor	2	Does the voltage between the connector J219-4 (MON*) on the DC controller PCB and the connector J219-5 (GND) change from about 5 to 0 V when the power is turned on?	YES	Replace the main motor.
			NO	Replace the DC controller PCB.

6 E013

Cause	Step	Checks	Yes/No	Action
Waste toner case	1	Is the photosensitive drum cartridge full of waste toner?	YES	Replace the photosensitive drum cartridge.
			NO	Replace the DC controller PCB.

7	E019
----------	-------------

Cause	Step	Checks	Yes/No	Action
Waste toner detection window	1	Is the waste toner detection window of the photosensitive drum soiled?	YES	Wipe the waste toner detection window with a dry cloth.
Connectors	2	Are the connector J21 on the DC controller PCB, connectors J631 and J633 of the waste toner sensor, and the relay connector J71 connected securely?	NO	Connect the connectors securely.
Waste toner detecting block (light-emitting/-receiving section; printer unit)	3	Is the light-emitting/-receiving section of the waste toner detection block of the printer unit soiled?	YES	Dry wipe the light-emitting/-receiving section of the waste toner detection block with a dry cloth.
Waste toner detection block (printer unit)	4	Replace the waste toner detection block of the printer unit. Is the problem corrected?	YES	End.
			NO	Replace the photosensitive drum unit. If the problem cannot be corrected, replace the DC controller PCB.

8	E020
----------	-------------

Cause	Step	Checks	Yes/No	Action
Density sensor (light-emitting/-receiving section)	1	Is the density sensor soiled?	YES	Clean the density sensor with the special brush.
Connector (density detection PCB)	2	Are the connector J1101 on the density detection PCB, relay connectors J75 and J46, and connector J206 on the DC controller PCB connected securely?	NO	Connect the connectors securely.
Density detection PCB	3	Is the voltage between the connectors J206-5 (+24 UH) on the density detection PCB and GND 24 V when the printer unit is turned on?	NO	Replace the density detection PCB.
			YES	Replace the DC controller PCB.

9	E021
----------	-------------

Cause	Step	Checks	Yes/No	Action
Toner cartridge	1	Does the shutter of each toner cartridge open properly (as it is set in the printer unit)?	NO	Replace the toner cartridge whose shutter is not open.
Developing rotary motor drive assembly	2	Close the toner cartridge cover, and turn off then on the power. Is the developing rotary stopper arm still holding the developing rotary assembly in place?	YES	Go to step 6.
			NO	Go to step 3.
Connector (developing rotary drive assembly)	3	Are the connectors J704 and J706 on the developing rotary motor PCB and the connector J220 on the DC controller PCB connected securely?	NO	Connect the connectors securely.
5V supply line (developing rotary position sensor)	4	Are the connector J43 of the developing rotary position sensor, relay connector J42, and connector J207 on the DC controller PCB connected securely?	NO	Connect the connectors securely.
Developing rotary position sensor	5	Replace the developing rotary position sensor. Is the problem corrected?	YES	End.
Developing rotary stopper	6	Is the operation of the developing rotary stopper arm normal? Disconnect the connector J705 of the developing rotary stop solenoid (SL5); then, measure the resistance between connectors J605-10 and J605-12 on the harness side and between J705-11 and J705-12. Is it about 30 Ω to 60 Ω?	NO	Replace the developing rotary stopper solenoid.
Developing rotary motor PCB	7	Does the voltage between the connectors J220-A6 (RLSROT) and J220-B5 (GND) on the DC controller PCB change from about 0 to about 3.5 V immediately after the printer unit is turned on?	YES	Replace the developing rotary motor PCB.
Fuse (developing rotary motor PCB)	8	Is the fuse (FU701, FU702) on the developing rotary motor PCB blown?	YES	Replace the fuse.
			NO	Replace the developing rotary motor. If the problem cannot be corrected, replace the DC controller PCB.

10	E040
-----------	-------------

Cause	Step	Checks	Yes/No	Action
Connectors	1	Are the connector J213 on the DC controller PCB, connectors J641, J642, J643, and J647 on the printer side main relay PCB, connectors J671 and J672 on the sub relay PCB, connector J1302 of the holding plate solenoid, and connector J102 of the power supply connected securely?	NO	Connect the connectors.
Multifeeder tray PCB	2	Does the voltage between the connectors J1301-2 (+24 UH) and J1301-1 (GND) on the multifeeder tray PCB change from 0 to 24 V?	YES	Replace the multifeeder tray PCB.
+24 UH	3	Is +24 UH present on the multifeeder tray PCB and the holding plate solenoid?	NO	See B.5. "+24 UH is absent."
Holding plate solenoid	4	Disconnect the connector J1302 of the holding plate solenoid from the multifeeder tray PCB. Measure the resistance between the connectors J1302-1 (MPTSLD*) and J1302-2 (+24 UH) on the harness side. Is it about 160 Ω ?	NO	Replace the holding plate solenoid.
			YES	Replace the DC controller PCB.

11	E054
-----------	-------------

Cause	Step	Checks	Yes/No	Action
Duplexing feeding roller 1 home position sensor lever	1	Is the duplexing feeding roller 1 home position sensor lever damaged?	YES	Replace the lever.
Duplexing feeding roller drive gear	2	Is the drive gear of the duplexing feeding roller worn/cracked?	YES	Replace the worn/cracking gear.
Duplexing driver PCB	3	Are the connectors J2003, J2004 and J2007 on the duplexing driver PCB connected securely?	NO	Connect the connectors securely.
Duplexing feeding roller 1 home position sensor (PS23)	4	Replace the duplexing feeding roller 1 home position sensor. Is the problem corrected?	YES	Replace the sensor.
Duplexing feeding clutch (CL5)	5	Disconnect the connector J2003 of the duplexing feeding clutch, and measure the resistance between the connectors J2003-1 and J2003-2 on the harness side. Is it about 140 Ω?	NO	Replace the duplexing feeding clutch.
Duplexing motor (M8)	6	Replace the duplexing motor. Is the problem corrected?	YES	Replace the duplexing motor.
Duplexing driver PCB			NO	Replace the duplexing driver PCB.

12 E055

Cause	Step	Checks	Yes/No	Action
Horizontal registration guide	1	Is the horizontal registration guide mounted correctly?	NO	Mount the guide correctly.
Horizontal registration guide home position sensor (PS25) lever	2	Is the horizontal registration guide home position sensor lever damaged?	YES	Replace the lever.
Horizontal registration guide drive gear	3	Is the horizontal registration guide drive gear worn/cracked?	YES	Replace the worn/cracked gear.
Duplexing driver PCB	4	Are the connectors J2006 and J2005 of the duplexing driver PCB connected securely?	NO	Connect the connectors securely.
Horizontal registration guide home position sensor (PS25)	5	Replace the horizontal registration guide home position sensor (PS25). Is the problem corrected?	YES	Replace the sensor.
Horizontal motor (M7)	6	Replace the horizontal registration motor. Is the problem corrected?	YES	Replace the horizontal registration motor.
Duplexing driver PCB			NO	Replace the duplexing driver PCB.

13 E066

Cause	Step	Checks	Yes/No	Action
Connector (temperature/humidity sensor)	1	Are the connectors J801 on the temperature/humidity sensor and connector J206 on the DC controller PCB connected securely?	NO	Connect the connectors securely.
Temperature/humidity sensor	2	Replace the temperature/humidity sensor. Is the problem corrected?	YES	End.
			NO	Replace the DC controller PCB.

14 E100

Cause	Step	Checks	Yes/No	Action
Connector (laser driver signal line)	1	Are the connector J1001 on the laser driver PCB and connector J205 on the DC controller PCB connected securely?	NO	Connect the connectors securely.
Connectors (BD line)	2	Are the connector J2 on the BD PCB, relay connector J40, and connector J211 on the DC controller PCB connected securely?	NO	Connect the connectors securely.
Laser scanner unit	3	Is the voltage between the connectors J211-1 (+5 V) on the DC controller PCB and J211-3 (GND) 5 V immediately after the printer unit is turned on?	YES	Replace the laser scanner unit.
			NO	Replace the DC controller PCB.

15 E110

Cause	Step	Checks	Yes/No	Action
Connector	1	Are the connectors J901 on the laser scanner motor PC, relay connectors J40, and connector J211 on the DC controller PCB connected securely?	NO	Connect the connectors.
Laser scanner motor	2	Does the voltage between the connectors J211-7 (SCND) on the DC controller PCB and J211-6 (GND) change from 0 to 17 V or more when the printer unit is turned on?	YES	Replace the laser scanner motor.
			NO	Replace the DC controller PCB.

16 E196/E197/E198

Cause	Step	Checks	Yes/No	Action
DC controller PCB	1	Turn off and then on the printer unit. Is the problem corrected?	YES	End.
			NO	Replace the DC controller PCB.

17 E240

Cause	Step	Checks	Yes/No	Action
Interface cable	1	Is the interface cable used to connect the reader unit and the printer unit connected securely?	NO	Make the connections secure, and turn on the reader unit.
Video interface PCB, Reader controller PCB		Further, are the reader unit power cord and the printer unit power cord connected securely?	YES	Replace the video interface PCB or the reader controller PCB of the reader unit.
PS/PCL board	2	<ul style="list-style-type: none"> If the printer unit is equipped with both a PS/PSL board and a reader unit, Remove the PS/PCL board, and turn on the printer unit/reader unit as one (as a copier). Is E240 indicated? If the printer unit is equipped with only a PS/PCL board, Try replacing the PS/PSL board and the DC controller PCB one after the other. 	NO	Replace the PS/PCL board.
DC Controller PCB			YES	Replace the DC controller PCB.

18 E677/E678/E679

Cause	Step	Checks	Yes/No	Action
Accessories power	1	Are the power cables of the accessories and the communication cable to the printer unit connected securely?	NO	Turn off and then on the power.
Accessories			YES	Replace the ACC controller PCB.

19 E805

Cause	Step	Checks	Yes/No	Action
Connectors (heat discharge fan 1 drive assembly)	1	Are the connectors J702 and J706 on the developing rotary motor PCB and the connector J220 on the DC controller PCB connected securely?	NO	Connect the connectors.
Connectors (24 V for heat discharge fan 1 drive)	2	Are the connector J701 on the developing rotary motor PCB, connectors J648 and J641 on the main relay PCB, and J102 on the DC power supply connected securely?	NO	Connect the connectors.
Heat discharge fan 1	3	Does the voltage between the connectors J702-3 (FAN1ON) on the developing rotary motor PCB and J702-1 (GND) change to about 24 V?	YES	Replace the heat discharge fan 1.
Developing rotary motor PCB	4	Does the voltage between the connectors J701-1 (+24 VB) and J701-2 (GND) on the developing rotary motor PCB change to about 24 V immediately after the printer unit is turned on?	YES	Replace the developing rotary motor PCB.
Main relay PCB	5	Does the voltage between the connectors J641-1 (+24 VB) and J641-4 (GND) on the main relay PCB change to 24 V immediately after the printer unit is turned on?	YES	Replace the main relay PCB.
DC power	6	Is the DC power present?	NO	See B.4. "DC power is absent in the printer unit."
			YES	Replace the DC controller PCB.

20	E806
-----------	-------------

Cause	Step	Checks	Yes/No	Action
Connectors (heat discharge fan 2 drive assembly)	1	Are the connectors J703 and J706 on the developing rotary motor PCB and the connector J220 on the DC controller PCB connected?	NO	Connect the connectors.
Connectors (24 V for heat discharge 2 drive)	2	Is the connector J701 on the developing rotary motor PCB, connectors J648 and J641 on the main relay PCB, and connector J102 on the DC power supply connected securely?	NO	Connect them securely.
Heat discharge fan 2	3	Does the voltage between the connector J703-3 (FAN2ON) and J703-1 (GND) on the developing rotary motor PCB change to about 24 V immediately after the printer unit is turned on?	YES	Replace the heat discharge fan 2.
Developing rotary motor PCB	4	Does the voltage between the connector J701-1 (+24 VB) on the developing rotary motor PCB and J701-2 (GND) on the developing rotary motor PCB change to 24 V immediately after the printer unit is turned on?	YES	Replace the developing rotary motor PCB.
Main relay PCB	5	Does the voltage between the connectors J641-1 (+24 VB) on the main relay PCB and J641-4 (GND) change to 24 V immediately after the printer unit is turned on?	YES	Replace the main relay PCB.
DC power supply (printer unit)	6	Is DC power present in the printer unit?	NO	See B.2. "DC power is absent in the printer unit."
			YES	Replace the DC controller PCB.

21 E807

Cause	Step	Checks	Yes/No	Action
Connectors (heat discharge fan 3 drive assembly)	1	Are the connectors J681 and J682 on the pre-exposure LED relay PCB and relay connectors J18 and J17, connectors J645 and J647 on the main relay PCB, and connector J227 on the DC controller PCB connected securely?	NO	Connect the connectors securely.
Connectors (24 V for heat discharge fan 3 drive)	2	Are the connectors J641 on the main relay PCB and J102 of the DC power supply connected securely?	NO	Connect them securely.
Heat discharge fan 3	3	Does the voltage between the connectors J645-3 (FAN3ON) on the main relay PCB and J645-1 (GND) change to about 24 V immediately after the printer unit is turned on?	YES	Replace the heat discharge fan 2.
Main relay PCB	4	Does the voltage between the connectors J641-1 (+24 VB) and J641-4 (GND) change to 24 V immediately after the printer unit is turned on?	YES	Replace the main relay PCB.
DC power (printer unit)	5	Is DC power present in the printer unit?	NO	See B.4. "DC power absent in the printer unit."
			YES	Replace the DC controller PCB.

22 E808

Cause	Step	Checks	Yes/No	Action
Fixing assembly	1	Replace the fixing assembly. Is the problem corrected?	YES	End.
Power supply (printer unit)	2	Replace the power supply on the printer side. Is the problem corrected? (The fixing heater drive circuit or the fixing heater safety circuit is faulty.)	YES	End.
			NO	Replace the DC controller PCB.

23 E810

Cause	Step	Checks	Yes/No	Action
Drum cartridge	1	Is the drum cartridge set in the printer unit correctly?	NO	Set the cartridge correctly, and turn off and then on the printer unit.
Drum cartridge switching lever	2	Check the drum cartridge switching lever on the printer side. Is it displaced or cracked?	YES	Set the lever to the correct position. If it is cracked, replace it.
Drum cartridge switching guide	3	Is the drum cartridge switching guide deformed?	YES	Replace the drum cartridge.
Connector (memory inside the drum cartridge)	4	Are the connector J209 on the DC controller PCB and relay connectors J47 and J48 connected securely?	NO	Connect the connectors securely.
Memory (inside the drum cartridge)	5	Replace the drum cartridge. Is the problem corrected?	YES	End.
			NO	Replace the DC controller PCB.

24 E812

Cause	Step	Checks	Yes/No	Action
Intermediate transfer drum (ITD), Density sensor	1	Is the intermediate transfer drum (ITD) set in the printer unit properly?	NO	Set the drum properly, and turn off and then on the power.
			YES	See "8.E020".

25 E813

Cause	Step	Checks	Yes/No	Action
Fixing assembly	1	Is the fixing assembly set in the printer unit properly?	NO	Set the fixing assembly properly, and turn off and then on the power.
Connector (fixing assembly)	2	Is the connector J26 of the fixing assembly connected securely?	NO	Connect the connector properly.
Connector (DC controller PCB)	3	Is the connector J222 on the DC controller PCB connected securely?	NO	Connect the connector.
			YES	Replace the DC controller PCB.

26 E814

Cause	Step	Checks	Yes/No	Action
Drum cartridge	1	Replace the drum cartridge. Is the problem corrected?	YES	End.
			NO	Replace the DC controller PCB.

27 E545/E546

See the Service Manual for the installed Sorter-H1.

28 E903

See the Service Manual for the installed paper deck.

29 SERVICE CALL CHECK READER

See the Reader Unit Service Manual.

30 Others

Turn off and then on the printer unit. If the problem is not corrected, replace the printer board. (For details, see the Service Manual for the PS/PCL Board.)

B. Faults Not Identified by Error Codes

No.	Item	Page	No.	Item	Page
1	AC power is absent in the printer unit.	10-46	12	The color toner cartridge is absent.	10-53
2	DC power is absent in the printer unit. (+5 V, +24 VB)	10-47	13	The color toner cartridge is not set properly.	10-54
3	+24 UH is absent.	10-48	14	The color toner cartridge has no toner.	10-54
4	+24 VAR is absent.	10-49	15	The black toner cartridge is absent.	10-55
5	The transparency sensor 1/2 is faulty.	10-50	16	The black toner cartridge has no toner.	10-55
6	The face-down tray full sensor is faulty.	10-50	17	The waste toner case is full.	10-56
7	The pick-up paper size is wrong.	10-51	18	The duplexing unit fails to turn on.	10-56
8	The cassette is absent.	10-51	19	The horizontal registration motor is faulty.	10-56
9	The cassette has no paper.	10-52	20	The duplexing motor is faulty.	10-57
10	The multifeeder tray has no paper.	10-52	21	The reversing roller releasing solenoid is faulty.	10-57
11	The multifeeder paper width is wrong.	10-53	22	The duplexing flapper solenoid is faulty.	10-57

1 AC power is absent in the printer unit.

Cause	Step	Checks	Yes/No	Action
Circuit breaker (printer unit)	1	Remove the power supply of the printer unit, and measure the resistance between both terminals of the circuit breaker. Is it 0 Ω?	NO	Press the button of the circuit breaker, and check for electrical continuity once again; if not 0 Ω, replace the circuit breaker. (See Note 1.)
Printer unit power switch (SW1; Note 2)	2	Remove the power supply of the printer unit, and connect the probes to both terminals of the power supply switch. Is the resistance 0 Ω when the printer unit power switch (Note 2) is turn on and ∞ Ω when it is turned off?	NO	Replace the printer unit power switch (SW1).
Power supply (printer unit)			YES	Check the AC power line and connectors for poor contact; if normal, replace the printer unit power supply.

Note:

- 1: Be sure to wait 60 sec after the circuit breaker has turned on before turning it back on. Be sure to turn on the power switch and check the AC line for a short circuit and the condition of the circuit breaker (continuity, and contact resistance) with a meter before connecting the printer unit power plug to the power outlet.
- 2: The printer unit power switch (SW1) is blocked by a face cover after turning on the printer unit at time of installing the reader unit. Do not touch unless this step must be performed. Be sure to turn it on, and attach the face cover after the work.

2 DC power is absent in the printer unit. (+5V, +24 VB)

Cause	Step	Checks	Yes/No	Action
AC power (printer unit)	1	Disconnect the power plug from the printer unit, and connect it to the power plug directly. Is AC power present?	NO	See 3. "AC power is absent in the printer unit."
Fuse (power supply of the printer unit)	2	Turn of the printer unit power switch ¹ ; in about 2 min, turn it on. Is the operation normal?	NO	Replace the fuse of the power supply of the printer unit.
Power supply (printer unit)	3	Turn off the printer unit power switch (Note 1), and disconnect the connector J204 from the DC controller PCB. Connect the printer unit power plug to the power outlet directly, and turn on the printer unit power switch. Is DC power (+5 V) present at the connector J204-1? (See Note 1.)	NO	Replace the printer unit power supply.
Wiring/DC load, DC controller PCB			YES	Check the wiring from the DC controller PCB; if normal, replace the DC controller PCB.

Note:

The printer unit power switch (SW1) is blocked by a face cover after turning on the printer unit at time of installing the reader unit. Do not touch unless this step must be performed. Be sure to turn it on, and attach the face cover after the work.

3 +24 UH is absent.

Cause	Step	Checks	Yes/No	Action
DC power (printer unit)	1	Disconnect the printer unit power plug from the reader unit connector, and connect it to the power plug directly. Is DC power present in the printer unit?	NO	4. "DC power is absent in the printer unit."
Connectors	2	Are the connectors J641 through J643 and J6476 of the main relay PCB, connectors J671 and J673 on the sub relay PCB, connector J102 of the power supply, and connector J227 on the DC controller PCB connected securely?	NO	Connect the connectors securely.
Right cover switch (main relay PCB)	3	Is there electrical continuity between the connectors J641-1 (+24 VB) and J642-3 (PMP) on the main relay PCB when the right cover switch (SW641) is turned on?	NO	Replace the right cover switch on the main relay PCB.
Delivery cover/front cover switch (sub relay PCB)	4	Is there electrical continuity between the connectors J671-1 (PMP) and J671-2 (PFUFR) on the sub relay PCB when the delivery cover/front cover switch (SW761) is turned on?	NO	Replace the delivery cover/front cover switch on the sub relay PCB.
Power supply (printer unit)	5	Disconnect the printer unit power plug from the reader unit, and connect it to the power outlet directly. Turn on the printer unit power switch (Note 1), and measure the voltage between the connectors J641 (+24 VB) on the main relay PCB and J641-4 (GND). Is it 24 V?	NO	Replace the printer unit power supply.
Main relay PCB	6	Disconnect the printer unit power plug from the reader unit, and connect it to the power outlet directly. Turn on the printer unit power switch (Note 1), and measure the voltage between the connectors J647-B11 (+24 UH) on the main relay PCB and J647-A1(GND). Is it 24 V?	NO	Replace the main relay PCB.
			YES	Replace the DC controller PCB.

Note:

The printer unit power switch (SW1) is blocked by a face cover after turning on the printer unit at time of installing the reader unit. Do not detach the cover unless this step must be performed. Be sure to turn it on, and attach the face cover after the work.

4	+24 VAR is absent.
----------	---------------------------

Cause	Step	Checks	Yes/No	Action
DC power supply (printer unit)	1	Disconnect the power plug from the printer unit, and connect it to the power outlet directly. Is DC power present in the printer unit?	NO	See 4. "DC power is absent in the printer unit."
Connectors	2	Are the connector J701 on the developing rotary motor PCB, connectors J641, J642, J644, and J648 on the main relay PCB, connector J672 on the sub relay PCB, and connector J102 of the power supply connected securely?	NO	Connect the connectors securely.
Right cover switch (main relay PCB)	3	Is there electrical continuity between the connectors J641-1 (+24 VB) and J642-3 (PMP) on the main relay PCB when the right cover switch (SW641) is turned on?	NO	Replace the right cover switch on the main relay PCB.
Black toner cartridge detecting switch	4	Is there electrical continuity between the connectors J644-1 (PBK) and J644-2 (PMP) on the main relay PCB when the black toner cartridge detecting switch (SW644) is turned on?	NO	Replace the black toner cartridge detecting switch (SW644).
Toner cartridge cover switch (SW672)	5	Is there electrical continuity between the connectors J642-1 (PYMC) and J642-2 (PBK) on the sub relay PCB when the toner cartridge cover switch (SW762) is turned on?	NO	Replace the toner cartridge cover switch (SW672) on the sub relay PCB.
Drum cartridge switch (SW642)	6	Is there electrical continuity between the connectors J642-1 (PYMC) and J648-1 (+24 VAR) on the main relay PCB when the drum cartridge switch (SW642) is turned on?	NO	Replace the drum cartridge switch (SW642) on the main relay PCB.
Main relay PCB	7	Disconnect the printer unit power plug from the reader unit, and connect it to the power outlet directly. Is the voltage between the connectors J648-1 (+24 VAR) and J648-3 (GND) on the main relay PCB 24 V when the printer unit power switch (Note 1) is turned on?	NO	Replace the main relay PCB.
			YES	Replace the DC controller PCB.

Note:

The printer unit power switch (SW1) is blocked by a face cover after turning on the printer unit at time of installing the reader unit. Do not detach the cover unless this step must be performed. Be sure to turn it on, and attach the face cover after the work.

5 The transparency sensor 1/2 is faulty.

Cause	Step	Checks	Yes/No	Action
Transparency sensor 1/2 (PS1801/PS1802)	1	Is the detecting window of the transparency sensor 1/2 (PS1801/PS1802) soiled?	YES	Clean the detecting window.
+5 V supply line	2	Are the connectors J1801 and J1802 of the transparency sensor 1/2, connector J214 on the DC controller PCB, and relay connector J17 connected securely?	NO	Connect the connectors securely.
Transparency sensor 1/2 (PS1801/PS1802)	3	Replace the transparency sensor 1/2 (PS1801/PS1802). Is the problem corrected?	YES	End.
			NO	Replace the DC controller PCB.

6 The face-down tray full sensor is faulty.

Cause	Step	Checks	Yes/No	Action
Lever (face-down tray full sensor PS10)	1	Is the lever of the face-down tray full sensor (PS10) damaged/deformed? Is the lever displaced?	YES	Replace or reposition the lever.
Face-down tray full sensor (PS10)	2	Replace the face-down tray full sensor (PS10). Is the problem corrected?	YES	End.
			NO	Replace the DC controller PCB.

7 The pick-up paper size is wrong.

Cause	Step	Checks	Yes/No	Action
Size detecting switch lever (cassette 1/2)	1	Is the size detecting switch lever of the cassette 1/2 deformed/damaged? Or, is the spring of the switch lever displaced?	YES	Replace the size detecting lever of the cassette 1/2, or position it correctly.
Contact (size detection PCB of the cassette 1/2)	2	Is the switch contact of the size detection PCB of the cassette 1/2 deformed/damaged?	YES	Replace the switch contact of the size detection PCB of the cassette 1/2.
+5 V supply line	3	Are the connectors J1601 on the cassette 1/2 size detection PCB and the connector J218 on the DC controller PCB connected securely?	NO	Connect the connectors.
Cassette 1/2 size detection PCB	4	Replace the cassette 1/2 size detection PCB. Is the problem corrected?	YES	End.
			NO	Replace the DC controller PCB.

8 The cassette is absent. (printer unit)

Cause	Step	Checks	Yes/No	Action
Cassette 1/2 sensor lever	1	Is the cassette 1/2 sensor lever damaged/deformed? Is the spring displaced?	YES	Replace the cassette 1/2 sensor lever, or position the spring correctly.
+5V supply line	2	Are the connectors J1201 on the pick-up PCB and the connector J210 on the DC controller PCB connected securely?	NO	Connect the connectors securely.
Cassette 1/2 sensor	3	Replace the cassette 1/2 sensor. Is the problem corrected?	YES	Replace the sensor.
Pick-up PCB, DC controller PCB	4	Replace the pick-up PCB. Is the problem corrected?	YES	End.
			NO	Replace the DC controller PCB.

9 The cassette is empty.

Cause	Step	Checks	Yes/No	Action
Cassette 1/2 lifter (paper level sensor lever)	1	Is the cassette 1/2 lifter (paper level sensor lever) damaged/deformed? Is the lifter spring displaced?	YES	Replace the cassette 1/2 lifter (paper level sensor lever). Position the spring correctly.
+5 V supply line	2	Are the connectors J1201 on the pick-up PCB and the connectors J210 on the DC controller PCB connected securely?	NO	Connect the connectors.
Cassette 1/2 paper level sensor	3	Replace the cassette 1/2 paper level sensor. Is the problem corrected?	YES	Replace the sensor.
Pick-up PCB, DC controller PCB	4	Replace the pick-up PCB. Is the problem corrected?	YES	End.
			NO	Replace the DC controller PCB.

10 The multifeeder is empty

Cause	Step	Checks	Yes/No	Action
Multifeeder tray paper sensor lever	1	Is the multifeeder tray paper sensor lever or the spring damaged/deformed? Is the lever or the spring displaced?	YES	Replace the multifeeder tray power sensor lever or the spring. Position them correctly.
+5V supply line	2	Are the connector J1301 on the multifeeder tray PCB and connector J213 on the DC controller PCB connected securely?	NO	Connect the connectors securely.
Multifeeder tray power sensor	3	Replace the multifeeder tray power sensor. Is the problem corrected?	YES	Replace the sensor.
Multifeeder tray PCB, DC controller PCB	4	Replace the multifeeder tray PCB. Is the problem corrected?	YES	End.
			NO	Replace the DC controller PCB.

11 The multifeeder paper width size is wrong.

Cause	Step	Checks	Yes/No	Action
Connectors	1	Are the connectors on the DC controller PCB, relay connector J33, and connector J34 of the multifeeder paper width sensor connected securely?	NO	Connect the connectors securely.
Multifeeder unit	2	Is there a fault in any of the parts of the multifeeder unit?	NO	Replace the problem part.
Multifeeder paper width sensor	3	Replace the multifeeder paper width sensor. Is the problem corrected?	YES	Replace the sensor.
DC controller PCB			NO	Replace the DC controller PCB.

12 The color toner cartridge is absent.

Cause	Step	Checks	Yes/No	Action
Connector	1	Are the connector J221 on the DC controller PCB, connector J621 of the color toner level sensor, and relay connector J70 connected securely?	NO	Connect the connectors securely.
Color toner sensor, DC controller PCB	2	Replace the color toner sensor. Is the problem corrected?	YES	End.
			NO	Replace the DC controller PCB.

13 The color toner cartridge is not set properly.

Cause	Step	Checks	Yes/No	Action
Cartridge locking lever (printer unit)	1	Is the cartridge locking lever of the printer unit displaced or cracked?	YES	If the lever is displaced, position it correctly. If it is cracked, replace it.
Connectors	2	Are the connector J1902 of the cartridge locking lever sensor, connector J207 on the DC controller PCB, and connectors J675 and J676 on the sub relay PCB connected securely?	NO	Connect the connectors securely.
Cartridge locking lever sensor	3	Replace the cartridge locking lever sensor. Is the problem corrected?	YES	Replace the sensor.
DC controller PCB			NO	Replace the DC controller PCB.

14 The color toner cartridge is empty.

Cause	Step	Checks	Yes/No	Action
Connectors	1	Are the connector J621 of the color toner level sensor, connector J227 on the DC controller PCB, connectors J643 and J647 on the main relay PCB, and connectors J673 and J675 on the sub relay PCB connected securely?	YES	Connect the connectors securely.
Color toner level sensor	2	Replace the color toner level sensor. Is the problem corrected?	YES	Replace the sensor.
DC controller PCB			NO	Replace the DC controller PCB.

15 The black toner cartridge is absent.

Cause	Step	Checks	Yes/No	Action
Black toner cartridge	1	Is the black toner cartridge set in the printer unit properly?	NO	Set the cartridge properly, and turn off and on the power.
Black toner cartridge switch lever (printer unit)	2	Is the black toner cartridge switch lever of the printer unit damaged/deformed? Is the lever displaced?	YES	Replace the lever, or position it correctly.
Boss (black toner cartridge)	3	Is the boss of the black toner cartridge deformed/damaged?	YES	Replace the black toner cartridge.
Connector (black toner cartridge detection)	4	Are the connector J227 on the DC controller PCB and connector J647 on the main relay PCB connected securely?	NO	Connect the connectors securely.
Black toner cartridge switch (SW644)	5	Is there electrical continuity between connectors J644-1 (PBK) and J644-2 (PMP) on the main relay PCB when the black toner cartridge switch (SW644) is turned on?	NO	Replace the black toner cartridge switch (SW644).
			YES	Replace the DC controller PCB.

16 The black toner cartridge is empty.

Cause	Step	Checks	Yes/No	Action
Connector (black toner level detection signal)	1	Are the connector J226 on the DC control PCB and connector J5001 on the high-voltage PCB 1 connected securely?	YES	Connect the connectors securely, and turn off and then on the power.
Contact (black toner cartridge for toner level detection), Contact (printer side toner level detection)	2	Are the contact of the black toner cartridge (for toner level detection) and the contact of the printer side toner level detection deformed/damaged?	YES	Replace the problem part. (If the problem part is on the black toner cartridge side, replace the black toner cartridge.)
			NO	Replace the DC controller PCB.

17 The waste toner case is full.

Cause	Step	Checks	Yes/No	Action
Drum cartridge	1	Replace the drum cartridge? Is the problem corrected? (The rotating mechanism of the stirring plate inside the drum cartridge may be faulty.)	YES	Replace it.
Drum drive assembly	2	Is any part of the drum drive assembly of the printer unit faulty?	YES	Replace the problem part.

18 The duplexing unit fails to turn on.

Cause	Step	Checks	Yes/No	Action
Duplexing unit	1	Is the duplexing unit set properly in the printer unit?	NO	Set it properly.
Connector (24V supply line)	2	Is the connector J2001 on the duplexing driver PCB connected securely?	NO	Connect the connector securely.
Duplexing driver PCB			YES	Replace the duplexing driver PCB.

19 The horizontal registration motor is faulty.

Cause	Step	Checks	Yes/No	Action
Connector (horizontal registration motor drive signal line)	1	Is the connector J2005 on the duplexing driver PCB connected securely?	NO	Connect the connector securely.
Horizontal registration motor (M7)	2	Replace the horizontal registration motor. Is the problem corrected?	YES	Replace it.
Duplexing driver PCB			NO	Replace the duplexing driver PCB.

20 The duplexing motor is faulty.

Cause	Step	Checks	Yes/No	Action
Connector (duplexing motor drive signal line)	1	Is the connector J2004 on the duplexing driver PCB connected securely?	NO	Connect it securely.
Duplexing motor (M8)	2	Replace the duplexing motor. Is the problem corrected?	YES	Replace the motor.
Duplexing driver PCB			NO	Replace the duplexing driver PCB.

21 The reversal roller releasing solenoid is faulty.

Cause	Step	Checks	Yes/No	Action
Connector (reversing roller releasing solenoid drive signal line)	1	Is the connector J2009 on the duplexing driver PCB connected securely?	NO	Connect the connector securely.
Reversing roller releasing solenoid (SL7)	2	Disconnect the connector J2009 of the reversing roller releasing solenoid, and measure the resistance between the connectors J2009-1 and J2009-2 on the harness side. Is it about 50 Ω ?	NO	Replace the reversing roller releasing solenoid.
Duplexing driver PCB			YES	Replace the duplexing driver PCB.

22 The duplexing flapper solenoid is faulty.

Cause	Step	Checks	Yes/No	Action
Connector (duplexing flapper solenoid drive signal line)	1	Is the connector J2002 on the duplexing driver PCB connected securely?	NO	Connect the connector securely.
Duplexing flapper solenoid (SL6)	2	Disconnect the connector J2002 of the duplexing flapper solenoid, and measure the resistance between the connectors J2002-1 and J2002-2 on the harness side. Is it about 130 Ω ?	NO	Replace the duplexing flapper solenoid.
Duplexing driver PCB			YES	Replace the duplexing driver PCB.

IV. TROUBLESHOOTING FEEDING PROBLEMS

A. Paper Jams

Inside the printer unit, jams tend to be limited to the following locations:

- ① Multifeder pick-up assembly
- ② Cassette pick-up assembly
- ③ Transfer/fixing assembly
- ④ Delivery assembly
- ⑤ Duplexing unit

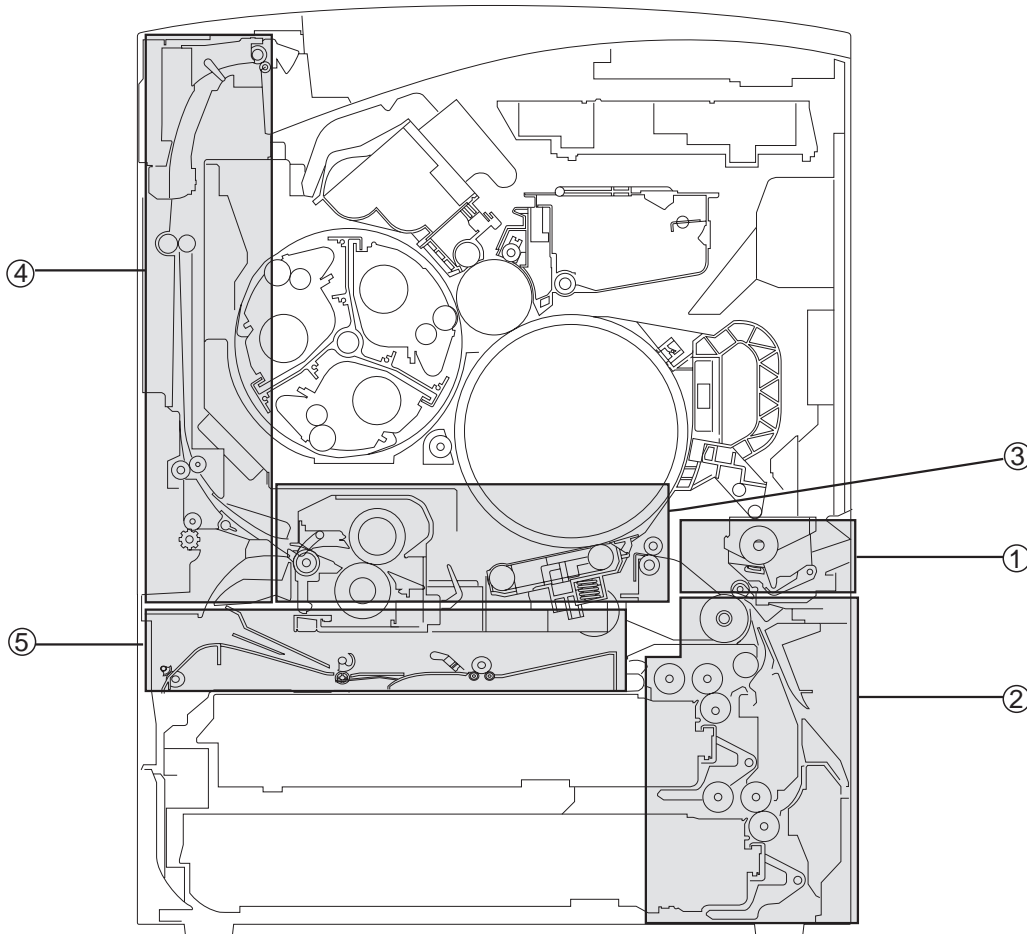

Figure 10-401

The troubleshooting procedures that follow are arranged according to location of jams.

Reference: _____

If the reader unit is installed, you can check the location and the type of any jam (last 50) in the copier in service mode (Display>JAM) on its control panel.

1	Multifeeder Pick-Up Assembly
----------	-------------------------------------

Cause	Step	Checks	Yes/No	Action
Multifeeder pick-up roller	1	Is the multifeeder pick-up roller soiled, worn, or deformed?	YES	Clean or replace the roller.
Drive gear	2	Remove the multifeeder pick-up assembly, and check the drive gears. Is there any damaged part?	YES	Replace the damaged part.
Multifeeder pick-up clutch (CL3)	3	Disconnect the connector J1303 of the multifeeder pick-up clutch from the multifeeder tray PCB, and measure the resistance between the connectors J1303-1 (MPTCLD*) and J1303-2 (+24 UH) on the harness side. Is it about 160 Ω ?	NO	Replace the multifeeder pick-up clutch.
Multifeeder tray paper sensor (PS1301)	4	Is the multifeeder tray paper sensor lever or spring damaged/deformed? Are they positioned correctly?	NO	Replace the multifeeder tray sensor lever and the lever. Position them correctly.
Multifeeder paper sensor (PS1301)	5	Replace the multifeeder tray paper sensor. Is the problem corrected?	YES	Replace the sensor.
Holding plate position sensor (PS1302)	6	Is the holding plate position sensor lever or spring damaged/deformed? Are they positioned correctly?	NO	Replace the holding plate position sensor lever or spring. Position them correctly.
Holding plate position sensor (PS1302)	7	Replace the holding position sensor. Is the problem corrected?	YES	Replace the sensor.
Connectors (holding plate solenoid SL4 drive; 24 V supply line)	8	Are the connector J213 on the DC controller PCB, connectors J641 through J643 and J647 on the main relay PCB, connectors J671 and J673 on the sub relay PCB, connector J1302 of the holding plate solenoid, and connector J102 of the power supply connected securely?	NO	Connect them securely.
Holding plate solenoid (SL4)	9	Disconnect the connector J1302 of the holding late solenoid from the multifeeder tray PCB, and measure the resistance between the connectors J1302-1 (MPTSLD*) and J1302-2 (+24 UH) on the harness side. Is it about 160 Ω ?	NO	Replace the holding plate solenoid.
Multifeeder PCB	10	Replace the multifeeder tray PCB. Is the problem corrected?	YES	Replace the PCB.
DC controller PCB			NO	Replace the DC controller PCB.

2 Cassette Pick-Up Assembly

Cause	Step	Checks	Yes/No	Action
Cassette pick-up roller, feeding roller 1	1	Is the cassette pick-up roller or the feeding roller 1 worn/deformed?	YES	Replace the parts. Be sure to replace both separation roller and feeding roller 1 at the same time.
Drive gear	2	Remove the pick-up assembly, and check the drive gears and springs. Is there any damaged/worn part? Is any spring displaced?	YES	Replace the damaged/worn part. Position the spring correctly.
Pick-up paper sensor (PS17)	3	Is the pick-up paper sensor lever or spring damaged/deformed? Are they positioned correctly?	YES	Replace the damaged/worn part. Position the spring correctly.
Pick-up paper sensor (PS17)	4	Replace the pick-up paper sensor. Is the problem corrected?	YES	Replace the sensor.
Connector (pick-up motor (M5) drive)	5	Are the connectors J210 on the DC controller PCB and connectors J1201 and J1202 on the pick-up PCB connected securely?	NO	Connect the connectors securely.
Pick-up motor (M5)	6	Replace the pick-up motor. Is the problem corrected?	YES	Replace the motor.
Feeding roller 2	7	Is the feeding roller 2 worn, deformed, or soiled?	YES	If worn or deformed, replace the roller. If soiled, clean it.
Connector (feeding clutch CL2 drive supply line)	8	Is the connector J1204 of the feeding clutch connected securely?	NO	Connect the connector.
Feeding clutch (CL2)	9	Disconnect the connector J1204 of the feeding clutch, and measure the resistance between the connectors J1204-2 (+24 UH) and J1204-1 (FEDCLD*) on the harness side. Is it about 210 Ω?	NO	Replace the feeding clutch.
Pick-up PCB	10	Replace the pick-up PCB. Is the problem corrected?	YES	Replace the pick-up PCB.
DC controller PCB			NO	Replace the DC controller PCB.

3	Transfer/Fixing Assembly
----------	---------------------------------

- A. After executing test printing in service mode, a jam occurs without the leading edge of print paper reaching the secondary transfer belt assembly.

Cause	Step	Checks	Yes/No	Action
Registration roller	1	Is the registration roller worn, deformed, or soiled?	YES	If damaged or worn, replace it. If soiled, clean it.
Connector (registration clutch CL1 drive 24 V supply line)	2	Are the connectors J212 on the DC controller PCB and the connector J37 on the relay PCB connected securely?	NO	Connect the connector.
Registration clutch (CL1)	3	Disconnect the connector J37 of the registration clutch, and measure the resistance between the connectors J37-1 (+24 UH) and J37-2 (REG-CLD*) on the harness side. Is it about 210 Ω ?	NO	Replace the registration clutch.
Registration paper sensor PS1 (detection mechanism)	4	Is the registration paper sensor (PS1) lever damaged or worn? Is there any displaced spring?	YES	Replace the damaged or worn part. Position the spring correctly.
Registration paper sensor (PS1)	5	Replace the registration paper sensor. Is the problem corrected?	YES	Replace the sensor.
DC controller PCB			NO	Replace the DC controller PCB.

B. After executing test print in service mode, the leading edge of print paper reaches the secondary transfer belt assembly. Or, the print paper is wrapping around the intermediate transfer drum.

Cause	Step	Checks	Yes/No	Action
Secondary transfer belt locking/unlocking drive gear	1	Is the drive gear used to transmit locking/unlocking drive of the secondary transfer belt worn or cracked?	YES	Replace the worn or cracked part.
Secondary transfer belt locking/unlocking drive cam	2	Is the drive cam used to transmit locking/unlocking drive of the secondary transfer belt worn or cracked?	YES	Replace the worn or cracked part.
Connector (secondary transfer belt locking/unlocking clutch CL4)	3	Are the connectors J212 on the DC controller PCB and the relay connector J36 connected securely?	NO	Connect the connectors securely.
Secondary transfer belt locking/unlocking clutch (CL4)	4	Disconnect the connector J212 of the secondary transfer locking/unlocking clutch, and measure the resistance between the connectors J212-1 (STRCLD*) and J212-2 (+24 UH) on the harness side. Is it about 130 Ω?	NO	Replace the secondary transfer belt locking/unlocking clutch.
Connector (drum motor M2)	5	Is the connector J224 on the DC controller PCB connected securely?	NO	Connect the connector securely.
Drum motor (M2)	6	Replace the drum motor (M2). Is the problem corrected?	YES	End.
DC controller PCB			NO	Replace the DC controller PCB?

Caution:

If the cause of the jam is the drum motor, the intermediate transfer drum can lock during initial rotation and trigger abnormal noise.

- C. After executing test printing in service mode, the leading edge of print paper jams at a location after the secondary transfer belt.

Cause	Step	Checks	Yes/No	Action
	1	Does the leading edge of print paper reach the fixing roller?	NO	Go to step 2.
			YES	Go to step 4.
Separation sensor (PS5)	2	Is the separation sensor lever or spring damaged or deformed? Is the spring of the sensor lever displaced?	YES	If damaged or deformed, replace the lever or the spring. Position the spring correctly.
Separation sensor (PS5)	3	Replace the separation sensor. Is the problem corrected?	YES	Replace the sensor.
Fixing roller drive gear	4	Is the fixing roller drive gear worn or cracked?	YES	Replace the worn or cracked drive gear.
Fixing assembly inlet guide, Fixing/separation upper guide, Fixing/separation lower guide	5	Is the fixing assembly inlet guide, fixing/separation upper guide, or fixing/separation lower guide soiled, scratched, or coated with toner?	YES	Clean the parts as necessary.
Upper fixing roller, Lower fixing roller	6	Is the upper fixing roller or the lower fixing roller soiled or coated with toner?	YES	Clean the upper fixing roller or the lower fixing roller.
Upper fixing roller, Lower fixing roller	7	Is the upper fixing roller or the lower fixing roller deformed or damaged?	YES	Replace the rollers as necessary.
Fixing/delivery sensor (PS1903) lever	8	Is the fixing/delivery sensor damaged or worn? Is the spring of the sensor lever displaced?	YES	Replace the damaged or worn lever. Position the spring correctly.
Fixing/delivery sensor (PS1903)	9	Replace the fixing/delivery sensor. Is the problem corrected?	YES	Replace the sensor.
Fixing delivery roller			NO	If the fixing /delivery roller is worn, replace it.

4 Delivery Assembly

Cause	Step	Checks	Yes/No	Action
Face-up flap- per	1	Is the face-up flapper soiled, scratched, or coated with toner?	YES	Clean the flapper
Face-up/face- down delivery roller	2	Is the face-up/face-down delivery roller worn?	YES	Replace the worn roller.
	3	Does the face-up/face-down delivery roller rotate smoothly?	NO	Check the gear for wear and deformation. Position the sensor lever correctly.
Face-down tray delivery paper sensor (PS11)	4	Is the face-down tray delivery paper sensor lever damaged or deformed? Is the sensor lever displaced?	YES	Replace the damaged or deformed lever. Position the sensor lever correctly.
5-V line (face- down tray delivery paper sensor PS11)	5	Are the connectors J220 on the DC controller PCB, connector J10 of the face-down tray delivery paper sen- sor, relay connector J12, and con- nectors J705 and J706 on the devel- oping rotary CB connected secure- ly?	NO	Connect the connec- tors securely.
Face-down tray delivery paper sensor (PS11)	6	Replace the face-down tray delivery sensor. Is the problem corrected?	YES	Replace the sensor.
Face-down tray full paper sen- sor (PS10)	7	Is the face-down tray full paper sen- sor lever damaged or deformed? Is the sensor lever displaced?	YES	Replace the damaged or deformed lever. Position the sensor lever correctly.
Face-down tray full paper sen- sor (PS10)	8	Replace the face-down tray full paper sensor. Is the problem cor- rected?	YES	Replace the sensor.
Duplexing flap- per	9	Does the duplexing flapper move smoothly? Is it damaged?	NO	Position the flapper correctly. If damaged, replace it.
DC controller PCB			YES	Replace the DC con- troller PCB.

5	Duplexing Unit
----------	-----------------------

Cause	Step	Checks	Yes/No	Action
Rollers (duplexing unit)	1	Are the rollers inside the duplexing unit coated with paper lint or dust?	YES	Remove the paper lint and dust.
Feeding guide	2	Is there foreign matter or burrs on the feeding guide?	YES	Remove any foreign matter. If burrs are found, replace the feeding guide.
Reversing roller, Duplexing feeding roller	3	Is the reversing roller or the duplexing feeding roller worn or deformed?	YES	If worn or deformed, replace the roller.
Drive gear	4	Is the drive gear worn or cracked?	YES	Replace the worn or cracked gear.
Sensor lever	5	Is any sensor lever damaged or deformed?	YES	Position the sensor lever correctly so that it moves smoothly. If damaged or deformed, replace it.
			NO	Replace the duplexing unit.

B. Faulty Feeding

1	Double Feeding
----------	-----------------------

Cause	Step	Checks	Yes/No	Action
/	1	Does the problem occur when the source is a cassette?	YES	Go to step 2.
			NO	If the source is the multi-feeder, go to step 5.
Separation roller	2	Is the separation roller worn or deformed?	YES	Replace the separation roller.
Spring	3	Is the spring used to pull the separation roller normal?	NO	Replace the spring.
Separation roller	4	Is the torque limiter of the separation roller normal?	NO	Replace the torque limiter.
Multifeeder separation pad	5	Is the surface of the multifeeder separation pad worn?	YES	Replace the multifeeder separation pad.
Spring	6	Is the spring used to push up the multifeeder separation pad normal?	NO	Replace the spring.

2	Wrinkles/Bending (leading)
----------	-----------------------------------

Cause	Step	Checks	Yes/No	Action
/	1	Execute test printing in serviced mode; then, open the front cover before the print paper enters the fixing assembly. At this time, is the print paper wrinkled or its leading edge bent?	NO	Go to step 2.
			YES	Go to step 8.
Fixing assembly inlet guide	2	Is the fixing assembly inlet guide soiled?	YES	Clean the fixing assembly inlet guide.
Lower fixing roller	3	Is the lower fixing roller soiled?	YES	Replace the lower fixing roller.
	4	Is the lower fixing roller scratched/deformed?	NO	Replace the lower fixing roller.
Upper fixing roller	5	Is the upper fixing roller soiled?	YES	Clean the upper fixing roller.
	6	Is the upper fixing roller scratched/deformed?	NO	Replace the upper fixing roller.
Face-down delivery roller, Face-up delivery roller	7	Is the face-down delivery roller or the face-up delivery roller coated with foreign matter or dirt?	YES	Clean the problem delivery roller.
Paper guide, Secondary transfer belt, Feeding roller, Registration roller	8	Is the paper guide, secondary transfer belt, feeding roller, or registration roller coated with foreign matter or dirt?	YES	Check the paper path, and clean the problem part.

3	Skew
----------	-------------

Cause	Step	Checks	Yes/No	Action
Feeding roller, Registration roller, Separation guide	1	Is the feeding roller, registration roller, or separation guide coated with paper lint or dust?	YES	Clean the problem part.
Registration roller	2	Is the spring of the registration roller deformed? Is the spring displaced?	YES	If the spring is deformed, replace it. If it is displaced, position it correctly.

4 Wrinkles (duplexing mode)

Cause	Step	Checks	Yes/No	Action
Feeding roller assembly, Horizontal registration guide	1	Is the feeding roller assembly or the horizontal registration guide coated with paper lint or dust?	YES	Clean the problem part.
Roller (inside the duplexing unit)	2	Is any of the rollers inside the duplexing unit worn or deformed?	YES	Replace any worn or deformed roller.
Paper guide	3	Check the paper feeding path. Is the paper guide scratched or deformed?	YES	Replace the scratched or deformed guide.

V.ARRANGEMENT AND FUNCTIONS OF ELECTRICAL PARTS

A. Sensors

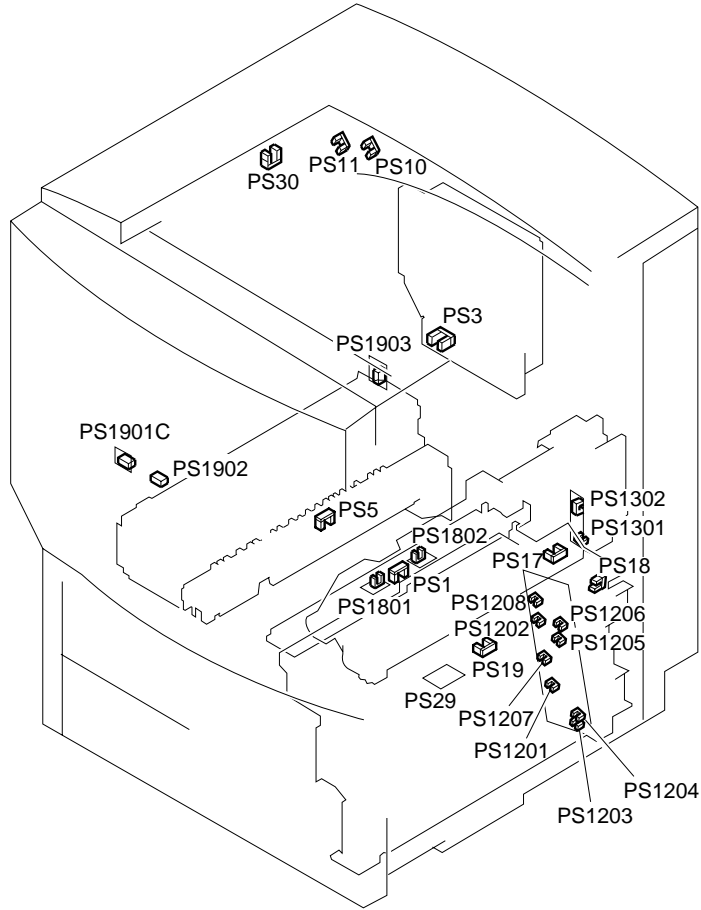

Figure 10-501

Symbol	Name	Notation	Description
	Photo-interrupter	PS1	Registration paper sensor
		PS3	Developing rotary position sensor
		PS5	Separation sensor
		PS10	Face-down tray full paper sensor
		PS11	Face-down tray delivery paper sensor
		PS17	Pick-up assembly paper sensor
		PS18	Pick-up unit cover sensor
		PS19	Multifeeder tray last sheet sensor
		PS30	Upper left cover sensor
		PS1201	Cassette 2 sensor
		PS1202	Cassette 1 sensor
		PS1203	Cassette 2 paper level sensor 2
		PS1204	Cassette 2 paper level sensor 1
		PS1205	Cassette 1 paper level sensor 2
		PS1206	Cassette 1 paper lever sensor 1
		PS1207	Cassette 2 paper absent sensor
		PS1208	Cassette 1 paper absent sensor
		PS1301	Multifeeder tray paper sensor
	PS1302	Holding plate position sensor	
	Photosensor	PS29	Cassette 1 last paper sensor
		PS1801	Transparency sensor 1
		PS1802	Transparency sensor 2
		PS1903	Fixing delivery sensor
		PS1902	Color toner cartridge releasing lever sensor
		PS1901C	Color toner cartridge sensor

Table 10-501

B. Thermistors, Lamps, and Heaters

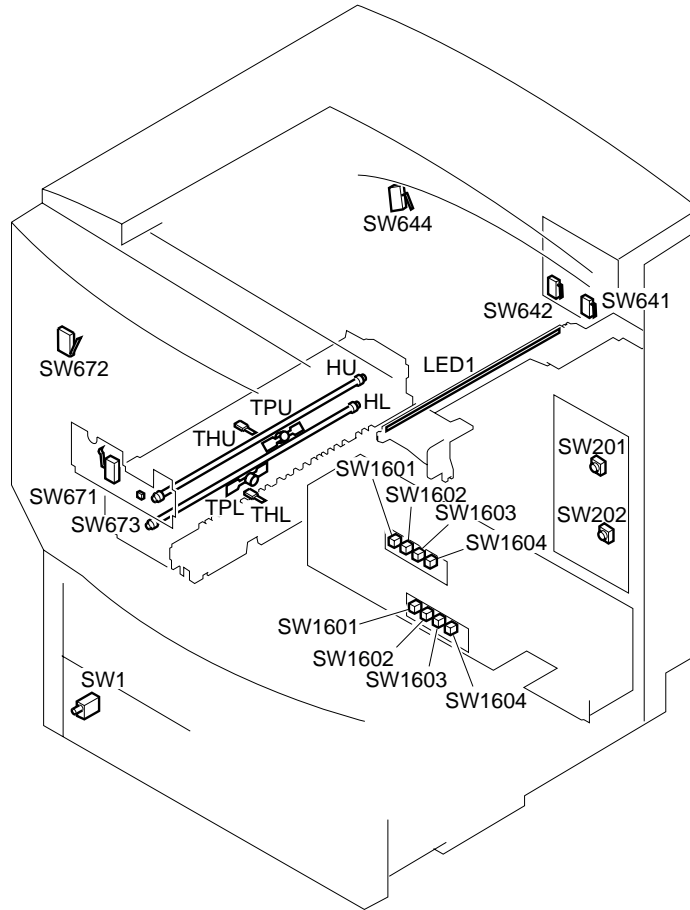

Figure 10-502





Symbol	Name	Notation	Description
	Thermistor	THU	Upper fixing thermistor
		THL	Lower fixing thermistor
	Thermal switch	TPU	Upper fixing thermal switch
		TPL	Lower fixing thermal switch
	Lamp	LED1	Pre-exposure LED assembly
	Heater	HU	Upper fixing heater
		HL	Lower fixing heater
	Switch	SW1	Printer unit power switch
		SW201	Test print switch
		SW202	Reset switch
		SW641	Right cover switch
		SW642	Drum cartridge switch
		SW644	Black toner cartridge switch
		SW671	Delivery cover/front cover switch
		SW672	Toner cartridge cover switch
		SW673	Turret button switch
		SW1601	Cassette 2 size detecting switch 1
		SW1602	Cassette 2 size detecting switch 2
		SW1603	Cassette 2 size detecting switch 3
		SW1604	Cassette 2 size detecting switch 4
		SW1601	Cassette 1 size detecting switch 1
		SW1602	Cassette 1 size detecting switch 2
SW1603	Cassette 1 size detecting switch 3		
SW1604	Cassette 1 size detecting switch 4		

Table 10-502

C. Clutches and Solenoids

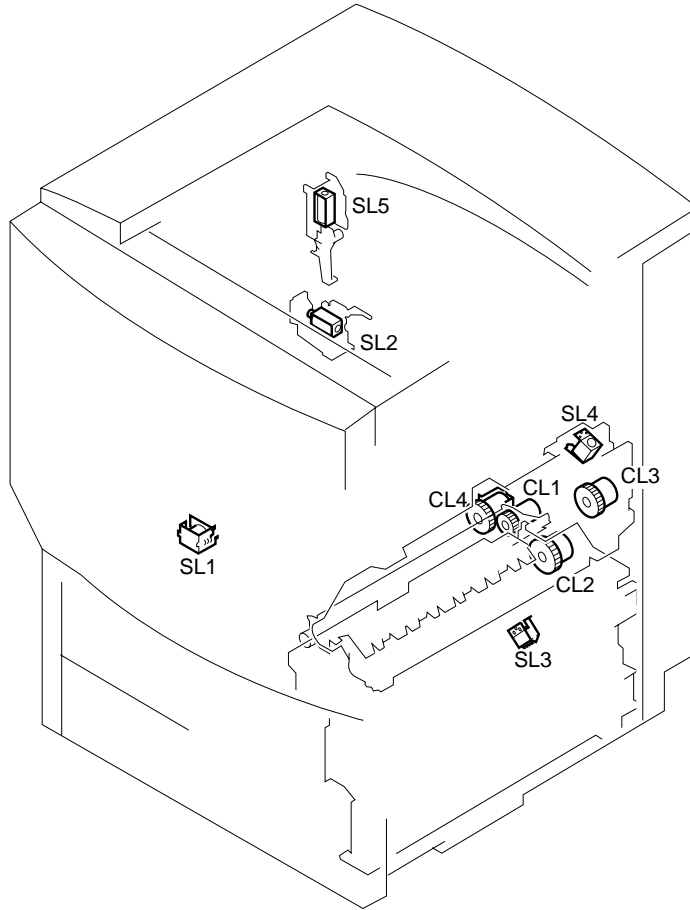

Figure 10-503



Symbol	Name	Notation	Description
	Clutch	CL1	Registration clutch
		CL2	Feeding clutch
		CL3	Multifeeder pick-up clutch
		CL4	Secondary transfer belt clutch
	Solenoid	SL1	ITD cleaning roller solenoid
		SL2	Face-up solenoid
		SL3	Cassette pick-up solenoid
		SL4	Holding plate solenoid
		SL5	Developing rotary stopper solenoid

Table 10-503

D. Fans and Motors

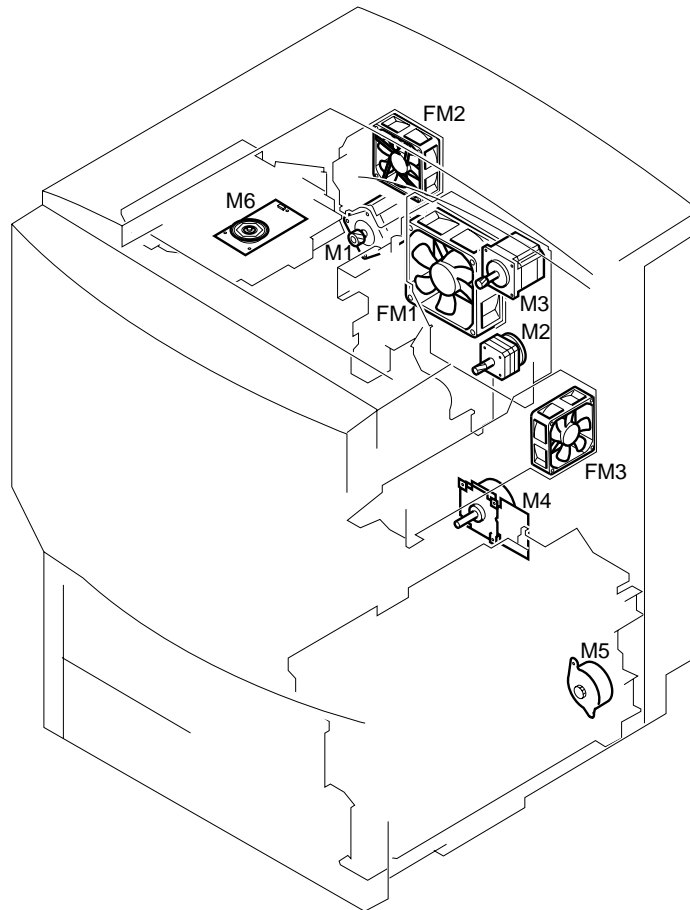

Figure 10-504



Symbol	Name	Notation	Description
	Fan	FM1 FM2 FM3	Heat discharge fan 1 Heat discharge fan 2 Heat discharge fan 3
	Motor	M1 M2 M3 M4 M5 M6	Developing rotary motor Drum motor Cartridge motor Main motor Pick-up motor Laser scanner motor

Table 10-504

E. PCBs

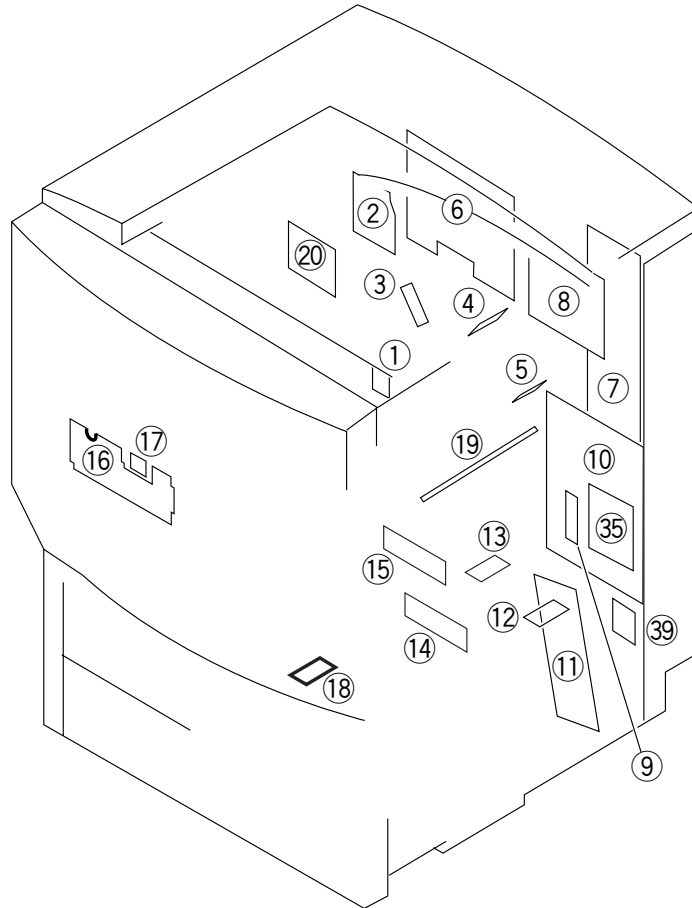

Figure 10-505

Ref.	Name	Description
①	Fixing delivery detection PCB	Detects paper passing through the fixing assembly.
②	Developing rotary motor PCB	Controls the rotation of the developing rotary.
③	Color toner level detection PCB	Detects the level of color toner.
④	Waste toner full detection PCB (light-receiving)	Detects the waste toner cartridge (when full; light-receiving section).
⑤	Waste toner full detection PCB (light-emitting)	Detects the waste toner cartridge (when full; light-emitting section).
⑥	High-voltage PCB 1	Controls the primary charging bias, black developing bias, and color developing bias.
⑦	High-voltage PCB 2	Controls the primary transfer bias, secondary transfer bias, secondary pre-transfer charging bias, fixing separation bias, and ITD cleaning roller bias.
⑧	Main relay PCB	Relays data among PCBs.
⑨	Multifeeder tray PCB	Controls the load on the multifeeder pick-up mechanism.
⑩	DC controller PCB	Controls the laser scanner, controls the video interface, and controls the temperature of the fixing assembly.
⑪	Pick-up PCB	Controls the load on the cassette pick-up mechanism.
⑫	Multifeeder tray paper width detection PCB	Detects the width of paper when the multifeeder tray is selected.
⑬	Density detection PCB	Detects the density of toner (each color).
⑭	Cassette 2 paper size detection PCB	Detects the size of paper in the cassette 2.
⑮	Cassette 1 paper size detection PCB	Detects the size of paper in the cassette 1.
⑯	Sub relay PCB	Relays data among loads.
⑰	Color cartridge detection PCB	Detects the presence/against of each color toner cartridge.
⑱	Temperature/humidity detection PCB	Checks the environment inside the machine.
⑲	Pre-exposure LED relay PCB	Relays data among loads.
⑳	Separation static eliminating bias PCB	Controls the separation static eliminating bias.
㉓	Video interface PCB	Relays data between reader unit and DC controller PCB.
㉙	ECO2 PCB	Assists the DC controller PCB.

Table 10-505

F. Duplexing Unit

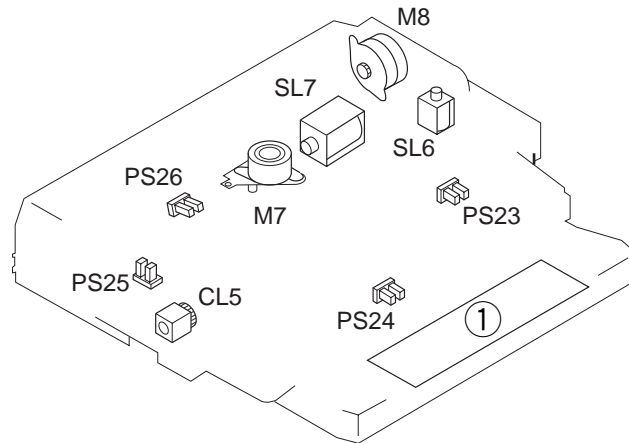

Figure 10-506

Symbol	Name	Notation	Description
	Clutch	CL5	Duplexing feeding clutch
	Photointerrupter	PS23 PS24 PS25	Duplexing feeding roller 1 home positioner Duplexing unit paper sensor Horizontal registration guide home position sensor
	Solenoid	PS26 SL6 SL7	Reversal paper sensor Duplexing flapper solenoid Reversing roller releasing solenoid
	Motor	M7 M8	Horizontal registration motor Duplexing motor

Ref.	Name	Description
①	Duplexing driver PCB	Controls various loads in the duplexing unit and checks various items.

Table 10-506



G. Variable Resistors (VR), Light-Emitting Diodes, and Check Pins PCB

Of those VRs, LEDs, and check pins used in the copier, those needed in the field are discussed.

Caution:

Do not touch the VRs and check pins not discussed herein. They are for the factory only and require special tools and high accuracy.

Caution:

1. Some LEDs emit dim light even when they are off. It is a normal condition, and must be kept in mind.
 2. VRs that may be used in the field ... 
- VRs that must not be used in the field ... 

1. Video Interface PCB

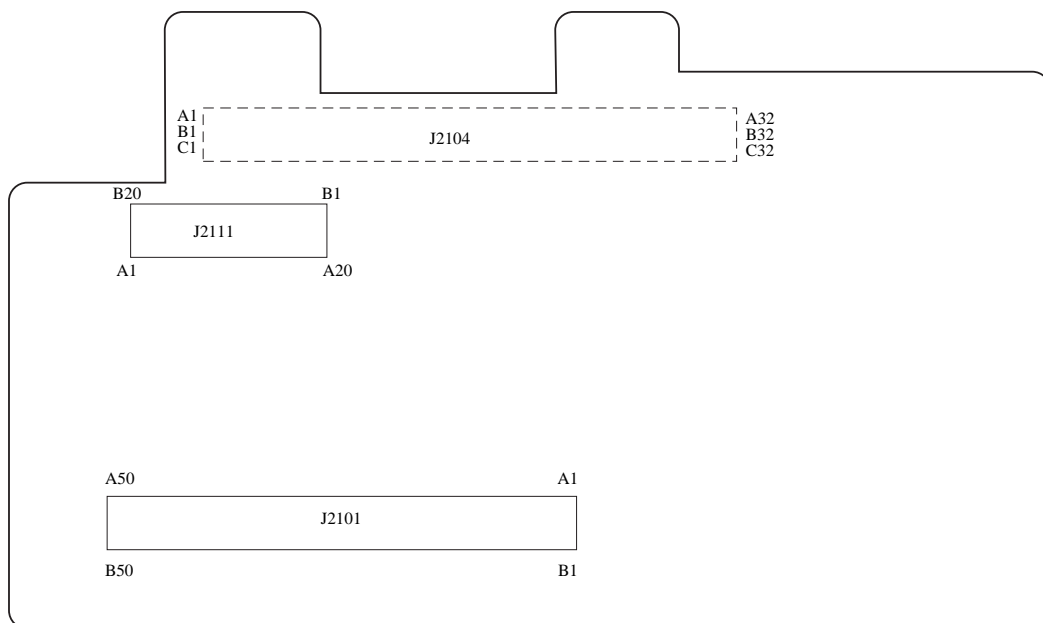
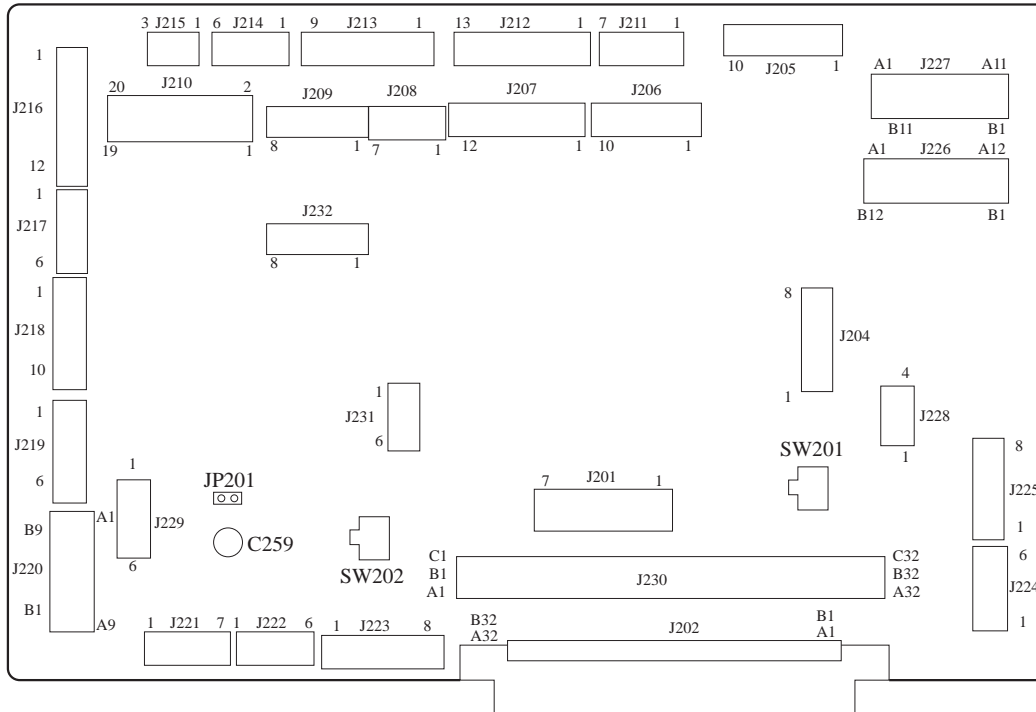

Figure 10-507

2. DC Controller PCB



SW No.	Name	Remarks
SW201	Test print switch	
SW202	Reset switch	For factory.

Figure 10-508

Caution: If E001 or E003 occurs, the error data may have been stored in the error memory capacitor (C259) on the DC controller PCB. Be sure to discharge the capacitor after removing the cause of the problem. (Short J201 on the DC controller PCB to discharge the capacitor.)

3. Main Relay PCB

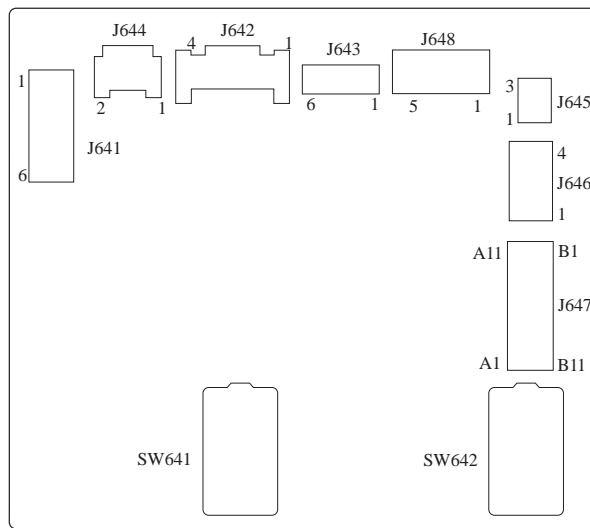

SW No.	Name
SW641	Right cover switch
SW642	Drum cartridge detecting switch

Figure 10-509

4. Sub Relay PCB

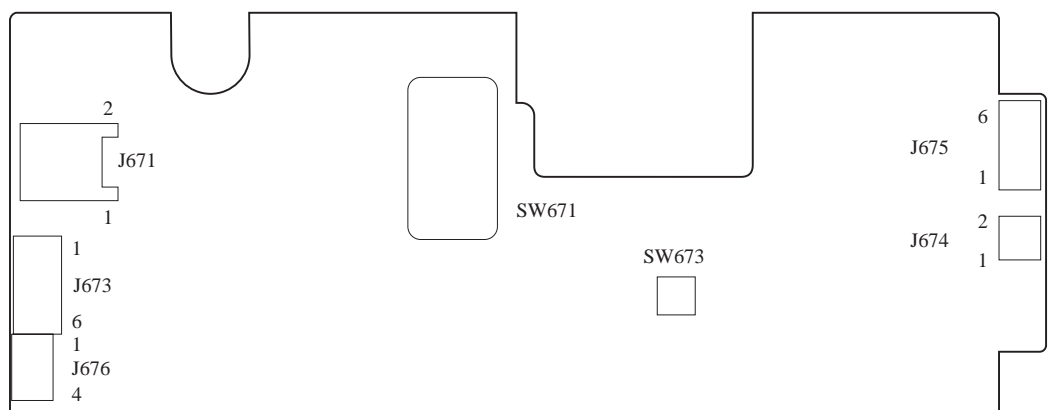

SW No.	Name
SW671	Delivery cover/front cover switch
SW672	Turret button switch

Figure 10-510

5. Cassette Size Detection PCB

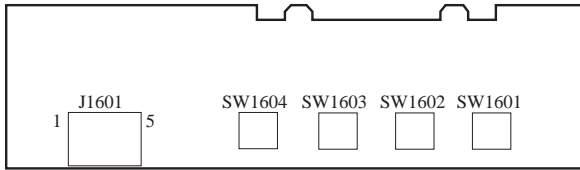

SW No.	Name
SW1601	Cassette detecting switch (p. 5-6)
SW1602	
SW1603	
SW1604	

Figure 10-511

VI. SERVICE MODE

The modes discussed herein are effective when the printer board (PS/PCL) is installed, and may be started on the control panel of the printer unit.

Caution:

If the reader unit is installed, service mode must be started by operating on the control panel of the Reader Unit. See the Reader Unit Service Manual.

A. Entering the Service Mode

To start service mode, turn on the printer unit while holding on the “Menu key, Enter/Online key, and Cancel key” on the control panel at the same time until “Start SELF-TEST” displays. The panel display will show “DISPLAY” to indicate that service mode has started after the printer unit checks itself.

B. Menu Structure and Key Assignment

There are following keys on the printer control panel. Basic function of each key is also described.

Name of the key	Function in main menu	Function in sub menu
UP	-	change the item to previous value
DOWN	-	change the item to next value
LEFT	-	-
RIGHT	-	-
CANCEL	exit service mode and reboot	switch to main menu
MENU	switch to next item of main menu	switch to main menu
ENTER/ONLINE	enter sub menu	display next item of sub menu

Table 10-601

Caution:

1. Do not disconnect the power cord while the printer is in service mode. (Be sure to turn off the power first to end service mode; however, do not turn off the power while test mode, read memory mode, or write memory mode is under way.)
2. When the power is turned on normally, various adjustment data in the EEPROM on the DC controller PCB is mounted to the printer unit and the paper is turned on normally, the data stored on the printer board will be lost. If you are replacing the DC controller PCB, be sure to write the various adjustment data in read memory mode to the RAM on the printer board, and then write it to the EEPROM on the new DC controller PCB in write memory mode.

Power Turned On Normally

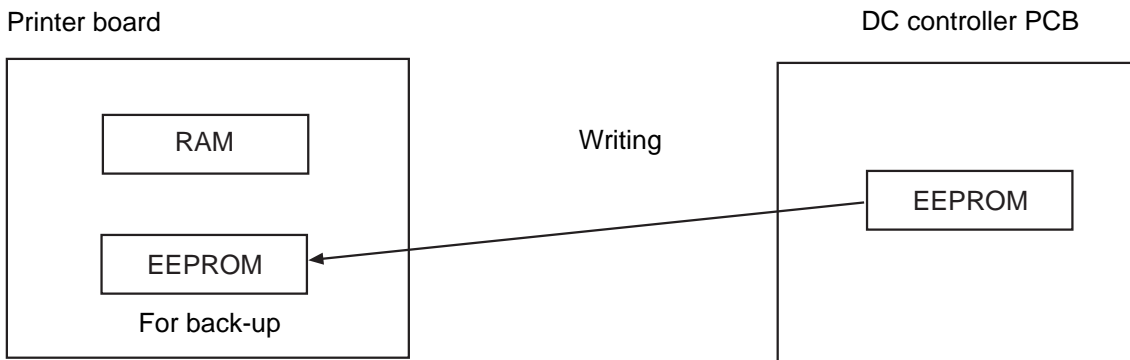

Figure 10-601

Power Turn On in Service Mode

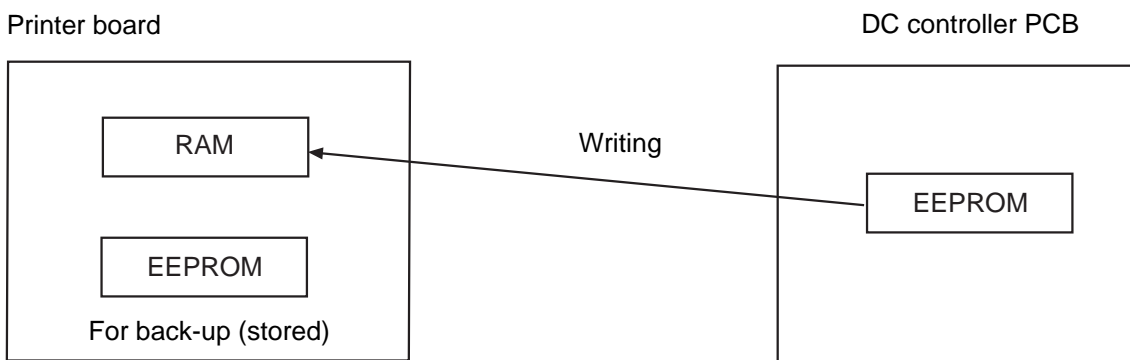

Figure 10-602

C. Main Menu

No.	Main Menu
1	DISPLAY
2	SENSOR MONITOR
3	TEST
4	PAPER FEED
5	READ MEMORY
6	PARAMETER
7	BIAS
8	WRITE MEMORY

Table 10-602

- After entering the service mode, the following message is displayed on LCD “DISPLAY”.
- If the “MENU” key is pressed, the next item of main menu is displayed on LCD.
- If the “MENU” key is pressed while “MESSAGE/NAME” is displayed, “DISPLAY” is displayed again.
- If the “MENU” key is pressed, go to the sub menu of each main menu items. For details, see the detail information of each main menu item.
- If the “CANCEL” key is pressed, exit service mode and reboot.

1. DISPLAY

Display mode is for displaying the status/configuration of the printer.

Sub Menu	Description	Remarks
DCON VERSION	Indicates the ROM version of the DC controller PCB. 'DCON VERSION MC:xx.yy DC:XX.YY' Indicates the version of the ROM which controls loads on the DC controller PCB (mechanical workings). 'XX.YY' Indicates the version of the ROM which control the communication between the video controller (PS/PCL) PCB on the DC controller PCB, controls high voltage, and controls some loads.	xx: version number yy: R&D number XX: version number YY: R&D number
DRUM LIFE	Indicates the life of the photosensitive drum inside the drum cartridge (at 126%, 'E814'). Note that '2: warning 2 (100%)' indicates that the copier may not be able to ensure a normal level of quality.	0: normal 1: warning 1 (70%) 2: warning 2 (100%) 4: drum cartridge memory error

2. SENSOR MONITOR

Sensor monitor mode is for displaying the state of the sensors in the paper path of the printer unit.

Sub Menu	Description	Remarks
SENSOR MONITORING	Use it to monitor the state of the sensors used in the printer unit. Turn on the sensor manually; the results of execution will be indicated on the control panel. For 'xx yy zz', see Table 10-603.	

Table 10-603 shows the display position and the display reading of each sensor.

Sensor	Display reading (hexadecimal)	Display position
Face-down tray delivery sensor (PS11)	10	xx
Fixing delivery sensor (PS1903)	08	
Separation sensor (PS5)	04	
Pick-up assembly sensor (PS17)	02	
Registration paper sensor (PS1)	01	
Lower cassette paper absent sensor (PS1207)	08	yy
Upper cassette paper absent sensor (PS1208)	02	
Multifeeder tray paper sensor (PS1301)	01	

Table 10-603

Caution:

1. The notation "zz" in the display panel (2nd row) is for checks at the factory, and is not relevant for servicing work.
2. Each sensor has its own response time, some requiring as much as 5 sec. Be sure to allow adequate time before making a decision.
3. If multiple sensors are turned on at once, the reading will be the sum of the results in hexadecimal notation.
4. Execution sensor monitor mode can drive some major parts. To avoid contact and, therefore, injuries, be sure to remove the intermediate transfer drum, various cartridges, and secondary transfer belt assembly before starting service mode.
In view of the work, remove the following for each respective sensor:
 - For PS1903 and PS5, remove the fixing assembly.
 - For PS11, remove the upper cover assembly.
 - For PS1207, remove the cassette 1.
 - For PS1208, remove the cassette 2.

3. TEST

Test mode is for checking while operating the printer unit.

Sub Menu	Description	Remarks
DEV-DRV	Use it to rotate the developing rotary cartridge and the cylinder for a specific period of time.	<ol style="list-style-type: none"> 1. Select 'DEV-DRV'. 2. Using the \wedge or \vee key, select 'YES'. 3. Press the ENTER key to execute.
MAIN-DRV	Use it to rotate the intermediate transfer drum and the photosensitive drum for a specific period of time.	<ol style="list-style-type: none"> 1. Select 'MAIN-DRV'. 2. Using the \wedge or \vee key, select 'YES'. 3. Press the ENTER key to execute.

Caution:

1. If you want to execute test mode while keeping the door covers open, use the door switch actuators to keep the door switches on.
2. Do not put your hand or face inside when checking the operation of the engine while the door cover is open.
3. Do not execute operation/inspection mode until the engine stops operation.

4. PAPER FEED

Use it to pick up one sheet of paper from the selected pick-up slot and deliver to the selected delivery slot.

Sub Menu	Description	Remarks
PAPER FEED	Before executing PAPER FEED mode, select the source of paper (cassette 1, cassette 2, multi-feeder).	1. Select 'PAPER FEED'. 2. Using the \wedge or \vee key, select the source of paper. 3. Press the ENTER key to execute.
OUTPUT FACE	Before executing PAPER FEED mode, select the destination (face-down delivery, face-up delivery).	4. Using the \wedge or \vee key, select the destination. 5. Press the ENTER key to execute.

Caution:

1. If you want to execute test mode while keeping the door covers open, use the door switch actuators to keep the door switches on.
2. Do not put your hand or face inside when checking the operation of the engine while the door cover is open.
3. Do not execute operation/inspection mode until the engine stops operation.

5. READ MEMORY

This mode is stored in the EEPROM on the printer board, and is used to read various backup data items (e.g., PARAMETER, BIAS) to the work area.

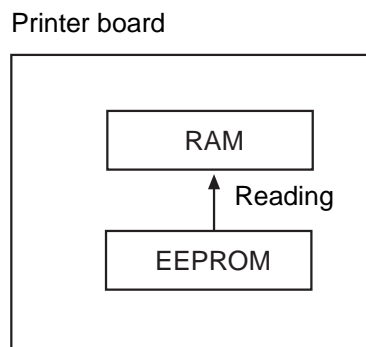

Figure 10-603

• Using READ MEMORY

- 1) Select <READ MEMORY>.
- 2) Press the ENTER key to select <READ FROM DCON>.
- 3) Using the \wedge or \vee key, select 'YES'.
- 4) Press the ENTER key to execute.
- 5) See that 'READ FROM DCON EXECUTING>' is indicated.
- 6) Turn off and then on the power to end.

6. PARAMETER

Parameter mode is for checking the adjustment data specific to each printer unit and stored in the EEPROM on the DC controller PCB at time of shipment. Normally, it is the data stored in the RAM on the printer board.

Changing each data item and executing memory write mode thereafter will update the data in the EEPROM on the DC controller PCB.

Sub Menu	Description	Remarks
REG-V-Y	Use it to fine-adjust the write start position (sub scanning) on the intermediate transfer drum for the Y pattern using M as reference. (1st page of 1-page mode, and 1st and 2nd pages of 2-page mode).	Unit: 1 pixel A higher setting will shift the pattern toward the rear. Settings: -7 to +8 Standard: 0 Enter setting, and execute 'WRITE MEMORY'.
REG-V-C	Use it to fine-adjust the write start position (sub scanning) on the intermediate transfer drum for the C pattern using M as reference. (1st page of 1-page mode, and 1st and 2nd pages of 2-page mode).	
REG-V-K	Use it to fine-adjust the write start position (sub scanning) on the intermediate transfer drum for the K pattern using M as reference. (1st page of 1-page mode, and 1st and 2nd pages of 2-page mode).	
REG2-V-Y	Use it to fine-adjust the write start position (sub scanning) on the intermediate transfer drum for the Y pattern using M as reference. (2nd and subsequent pages of 1-page mode, and 3rd and subsequent pages of 2-page mode).	
REG2-V-C	Use it to fine-adjust the write start position (sub scanning) on the intermediate transfer drum for the Y pattern using C as reference. (2nd and subsequent pages of 1-page mode, and 3rd and subsequent pages of 2-page mode).	
REG2-V-K	Use it to fine-adjust the write start position (sub scanning) on the intermediate transfer drum for the Y pattern using K as reference. (2nd and subsequent pages of 1-page mode, and 3rd and subsequent pages of 2-page mode).	
REG-V-M	Use it to set the leading edge registration for M to serve as a reference. (1st page of 1-page mode, and 1st and 2nd pages of 2-page mode).	
REG2-V-M	Use it to set the leading edge registration for M to serve as a reference. (2nd and subsequent pages of 1-page mode, and 3rd and subsequent pages of 2-page mode).	

Sub Menu	Description	Remarks
ADJ-C1	Use it to adjust the image write start position in main scanning direction when using the cassette 1.	Settings: 0 to +63 Standard: +32 Enter setting, and execute 'WRITE MEMORY'.
ADJ-C2	Use it to adjust the image write start position in main scanning direction when using the cassette 2.	
ADJ-MF	Use it to adjust the image write start position in main scanning direction when using the multi-feeder.	
RE-TR-SW	Use it to enable/disable the use of a remedy against re-transfer occurring in a high humidity environment. The Dmax control parameter will change, consequently changing the primary charging bias and the primary transfer bias to the appropriate settings.	0: disable remedy. 1: enable remedy in H/H. 2: enable remedy in H/H and N/N. Standard: 0 Enter setting, and execute 'WRITE MEMORY'.
TR-ON-SW	Use it to set the secondary transfer bias application timing if paper wraps around the intermediate transfer drum or separation faults occur.	Settings: 0 to +3 Standard: +1 Enter setting, and execute 'WRITE MEMORY'.
SP-1-SW	Enable separation static elimination if claw-like lines* or tread-like lines** occur because of low humidity when generating (printing) a 1st page in a normal temperature/normal humidity environment.	0: disable 1: enable Standard: 0 Enter setting, and execute 'WRITE MEMORY'.
SP-2-SW	Enable/disable separation static elimination if brush-like lines*** occur on some types of paper when printing a 2nd side in double-sided mode using auto/multifeeder mode in a high-temperature/humidity environment or when printing a 2nd side in double-sided mode using auto/multifeeder mode in a high-temperature/high-humidity environment.	0: disable (if brush-like occur) 1: enable (if claw-like lines occur) Standard: 1 Enter setting, and execute 'WRITE MEMORY'.
FIX-TEMP	Use it to enable/disable the fixing improvement mechanism for black halftone. (Set it to '1' to improve fixing of black halftone. However, note that doing so will increase the first print time by about 45 sec.)	0: disable 1: enable Standard: 0 Enter setting, and execute 'WRITE MEMORY'.

Note:

1. The term "1st page" means the first image formed on the intermediate transfer drum. In 2nd page mode, a 2nd page image is formed at the same time; as such, the term "1st page" is used to mean the first and second images formed on the drum.
2. The term "2nd page" means the second image formed on the intermediate transfer drum. In 2nd page mode, however, two pages of images are formed at the same time; as such, the term is used to mean the third and subsequent images formed on the drum.

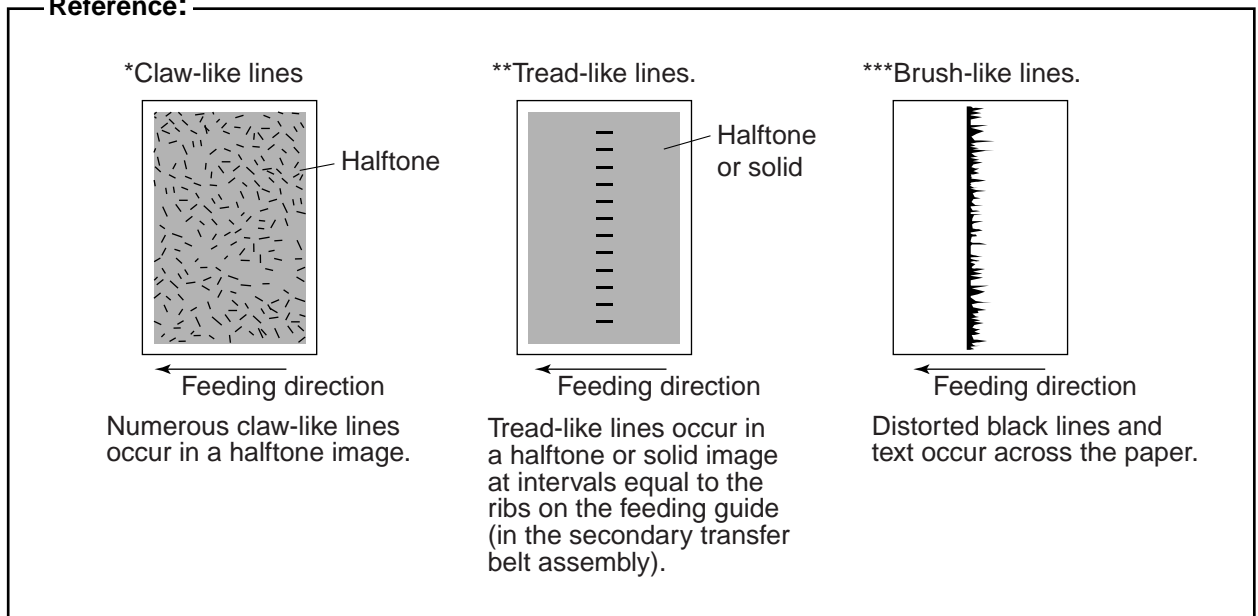
Reference:

7. BIAS

Use this item when adjusting the level of the secondary transfer bias to suit various environmental and printing conditions.

Sub Menu	Description	Remarks
TR-N1H	For a H/H environment, use it to adjust the secondary transfer bias for single-sided printing or first side printing of double-sided printing on plain paper.	Settings: 0 to +15 Standard: +8 Enter setting, and execute 'WRITE MEMORY'. Adjustment in the field is not usually needed.
TR-N2M	For a N/N environment, use it to adjust the secondary transfer bias for second side printing of double-sided printing on plain paper.	
TR-N2H	For a H/H environment, use it to adjust the secondary transfer bias for second side printing of double-sided printing on plain paper.	
TR-N2L	For a L/L environment, use it to adjust the secondary transfer bias for second side printing of double-sided printing on plain paper	
TR-N2N/L	For a N/L environment, use it to adjust the secondary transfer bias for second side printing of double-sided printing on plain paper.	

8. WRITE MEMORY

This memory is used to write the various adjustment data items (e.g., PARAMETER, BIAS) read into the RAM on the printer board to the EEPROM on the printer board and the EEPROM on the DC controller PCB.

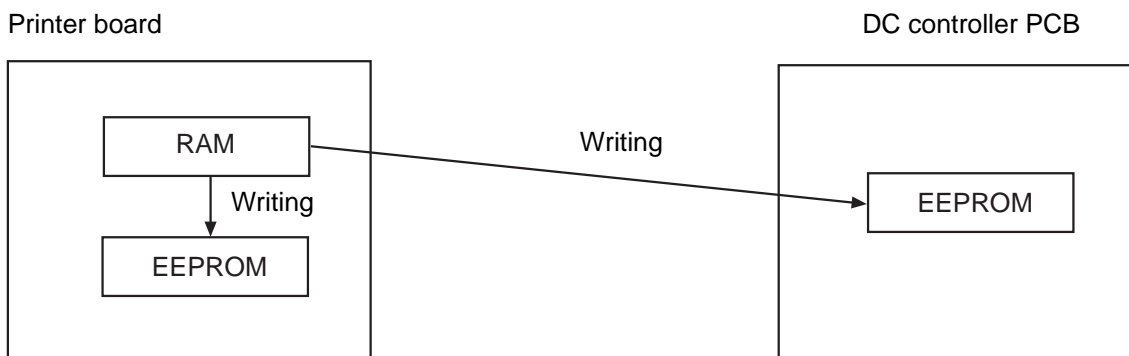

• Using WRITE MEMORY

- 1) Select <WRITE MEMORY>.
- 2) Press the ENTER key to select <WRITE TO DCON>.
- 3) Using the ^ or v key, select 'YES'.
- 4) Press the ENTER key to execute.
- 5) See that 'WRITE TO DCON EXECUTING' is indicated.
- 6) Turn off and then on the power to end.

VII. TEST PAGE PRINT MODE

The PS/PCL board has 5 types of test print patterns, each one enabling identification of a fault in the image.

A. Generating the Test Page

- 1) While holding down the Menu and Enter keys, turn on the power.
- 2) Hold down the Menu and enter keys until the message "START SELF-TEST" appears on the control panel of the printer.
- 3) Wait until the message "READY" appears as in the case of regular operation.
- 4) Press the Menu key several times to bring out the message "PRINT PAGES FROM LIST"; then, press the Enter key.
- 5) Press the Up or Down arrow several times until the message "PRINT SERVICE PAGE X" appears (X being 1 though 5, corresponding to the number of the chart shown above); then, press the Enter key.
- 6) See that the test page is printed.

Caution:

- If you have started the machine as you would normally, the above menu for service test page would not be indicated.
- For displacement of registration, use the test page intended for the engine side generated by pressing the DCON button. You may, however, use the test page generated by selecting "PRINT SERVICE PAGE 5".

B. Test Pattern

	TYPE	Remarks
1	PRINT SERVICE PAGE 1	Full-color 16 gradations (YMCK)
2	PRINT SERVICE PAGE 2	Gradation (YMCKRGB)
3	PRINT SERVICE PAGE 3	Full face halftone (Y, M, C, K)
4	PRINT SERVICE PAGE 4	YMCK vertical stripe
5	PRINT SERVICE PAGE 5	Controller Test Chart

Table 10-701

1. Full-color 16 gradations (YMCK)

Use the full-color 16-gradation (YMCK) test print to check the gray balance, gradation of each color (YMCK), and fogging.

Note:

- The page consists of patches of Bk, Y, RGB, M, and C.
- Cassette 2 is used as the source of paper.
- The page consists of a single sheet.
- Regardless of the size of paper, the patches are printed at the center.

a. Gray Balance

Check to find out if the gray scale is even for all colors.

b. Gradation

Check the gradation and the difference in density of each color (YMCK).

c. Fogging

If the white area is foggy, the photosensitive drum inside the drum cartridge or the laser system of the printer unit is likely to be faulty.

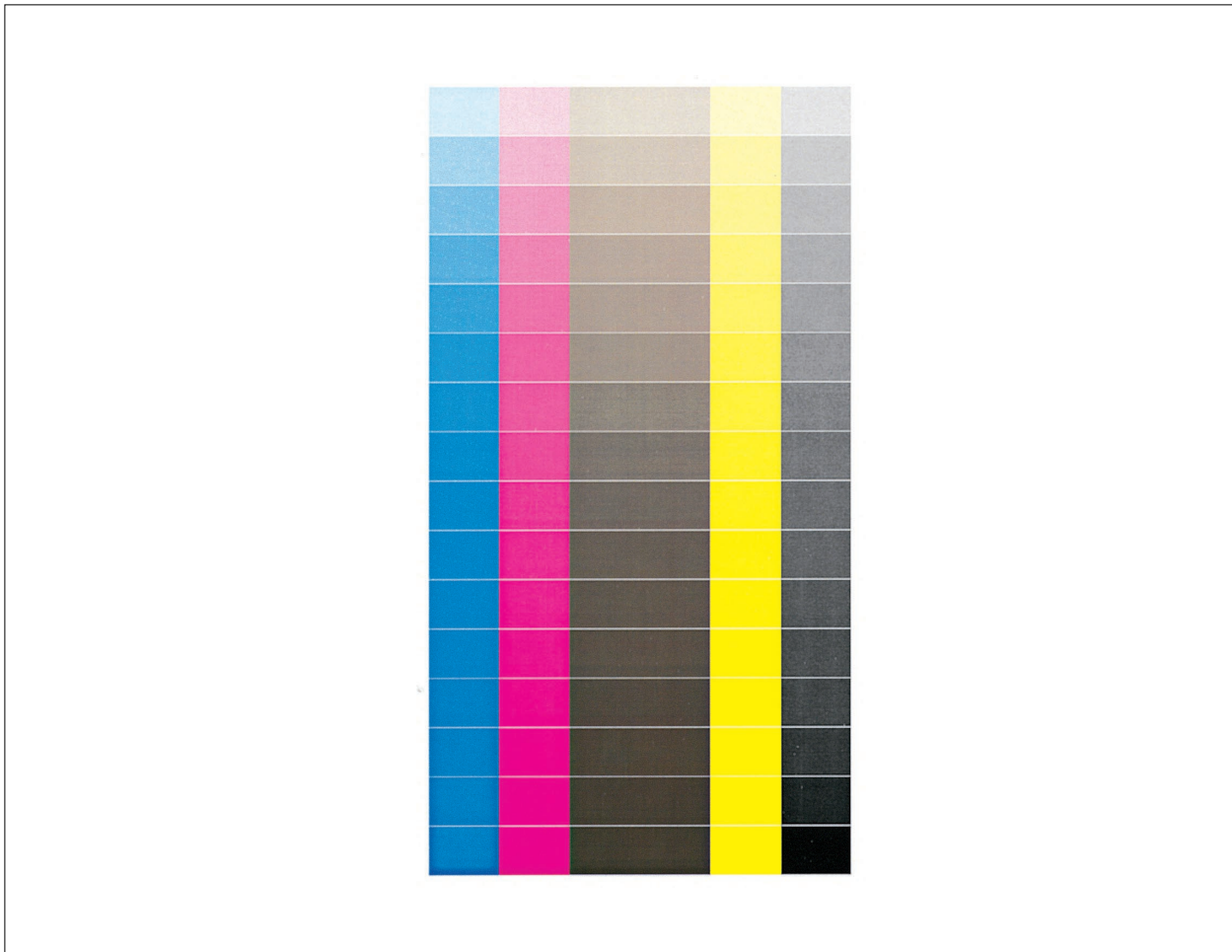

Figure 10-701

2. Gradation (YMCKRGB)

Use the gradation (YMCKRGB) test print to check the gradation of all colors (YMCKRGB) at a glance.

Note:

- The page consists of gradations of Bk, B, G, R, Y, M, and C.
 - Cassette 2 is used as the source of paper.
 - The page consists of a single sheet.
 - Regardless of the size of paper, the patches are printed at the center.
-

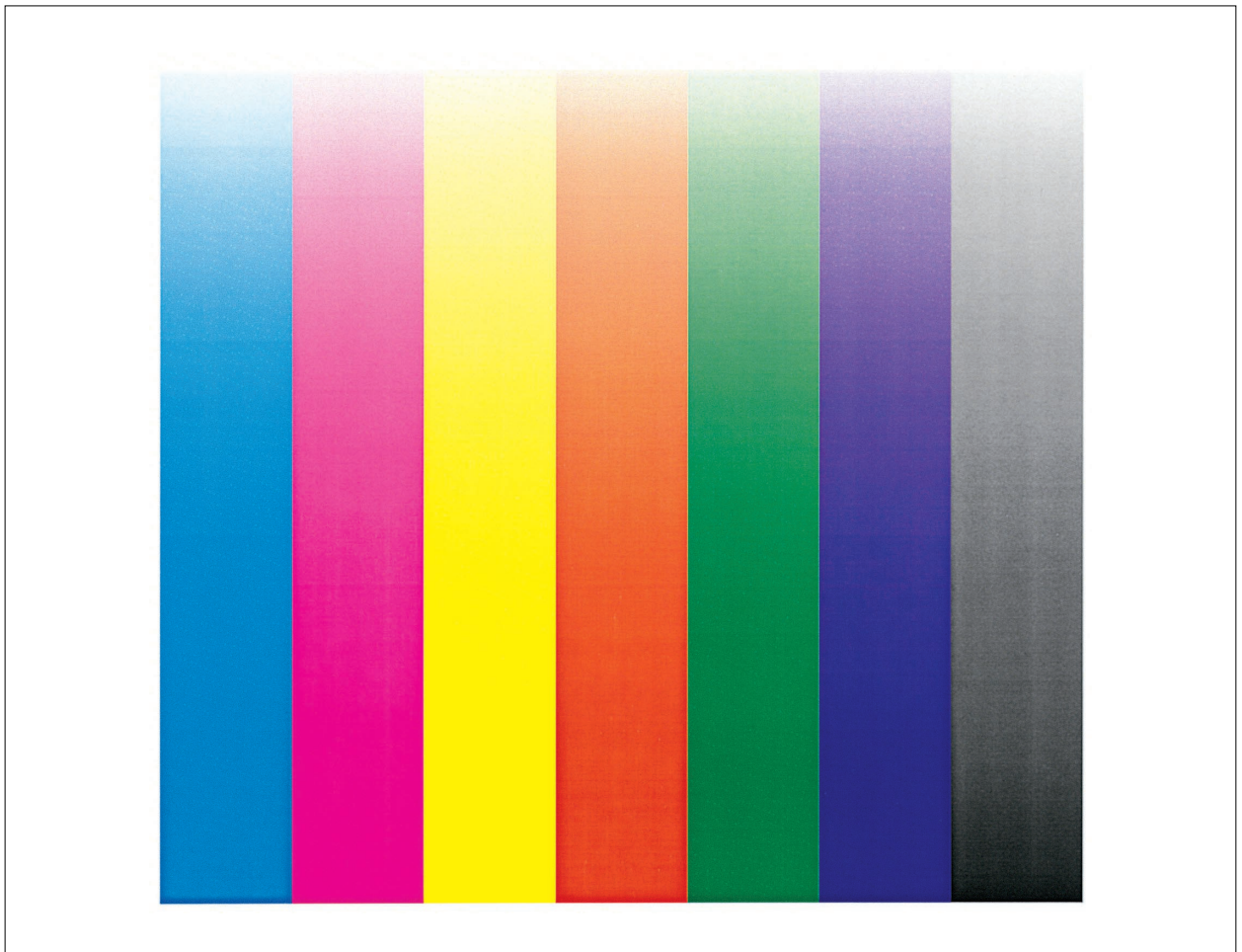

Figure 10-702

3. Full face halftone (Y, M, C, K)

Use the halftone test print to check transfer faults, black lines, white lines, and uneven intervals.

Note:

- The page consists of halftone solids of C, M, Y, and Bk.
- Cassette 2 is used as the source of paper.
- The page consists of a total of 4 sheets, one each for C, M, Y, and Bk.
- Halftone solids are printed within the entire printable area (guaranteed area).

a. Transfer Faults

If transfer faults occur, the intermediate transfer drum unit or the secondary transfer belt assembly of the printer unit is likely to be faulty.

b. Black Lines

If black lines occur, the photosensitive drum inside the drum cartridge of the printer unit is likely to have scratches or the primary charging roller is likely to be solid.

c. White Lines

If white lines occur at the same position in all colors, the intermediate transfer drum or the secondary belt assembly of the printer unit is likely to be faulty. If they occur at different positions or in one color, the toner cartridge of the printer unit is likely to be faulty.

d. Uneven Intervals

If uneven intervals occur, suspect the following:

- if at 66-mm intervals, the developing cylinder.
- if at about 52-mm intervals, the registration roller.

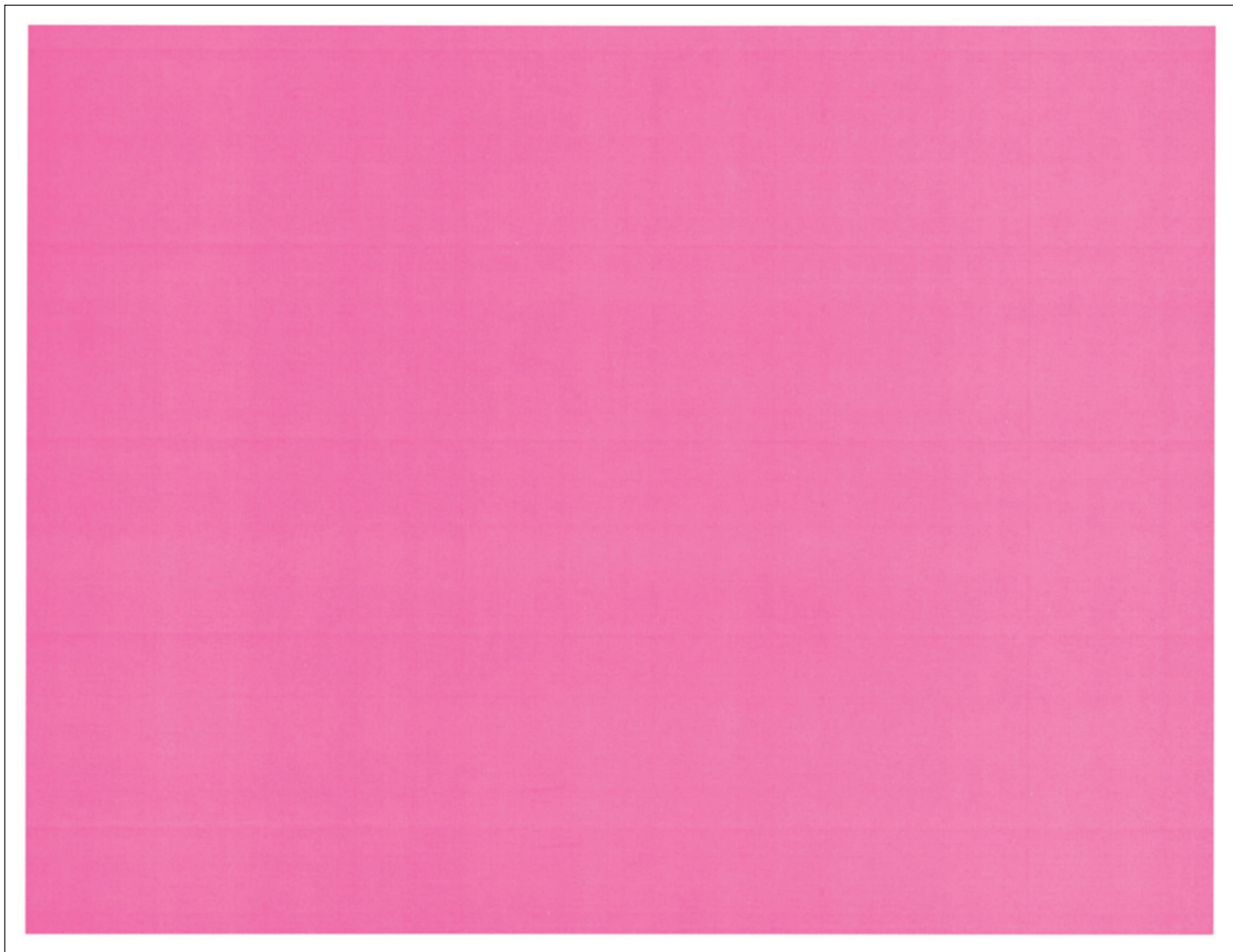

Figure 10-703

4. YMCK vertical stripe

Use the vertical test print to check the dark area density of each color, balance between colors, and white lines caused during development.

Note:

- The page consists of halftone strips of C, M, Y, and Bk.
 - Cassette 2 is used as the source of paper.
 - The page consists of a single sheet.
 - Strips of C, M, Y, and Bk are printed within the entire printable area (guaranteed area).
- a. Dark Area Density of Each Color and Balance between Colors
 - The density must not be appreciably low (light image).
 - If the density of one color is low (light image), the light-color toner cartridge is likely to be faulty.
 - If the density of all colors is low (light image), primary transfer/secondary transfer is likely to be faulty.
 - b. White Lines Caused during Development
 - If white lines are found in the cyan area of the copy, the cyan toner cartridge is likely to be faulty.
 - c. Uneven Density between Left and Right
 - If the right/left density is uneven for all colors, the drum cartridge, secondary pre-transfer charging assembly, or secondary transfer belt assembly of the printer unit is likely to be faulty.

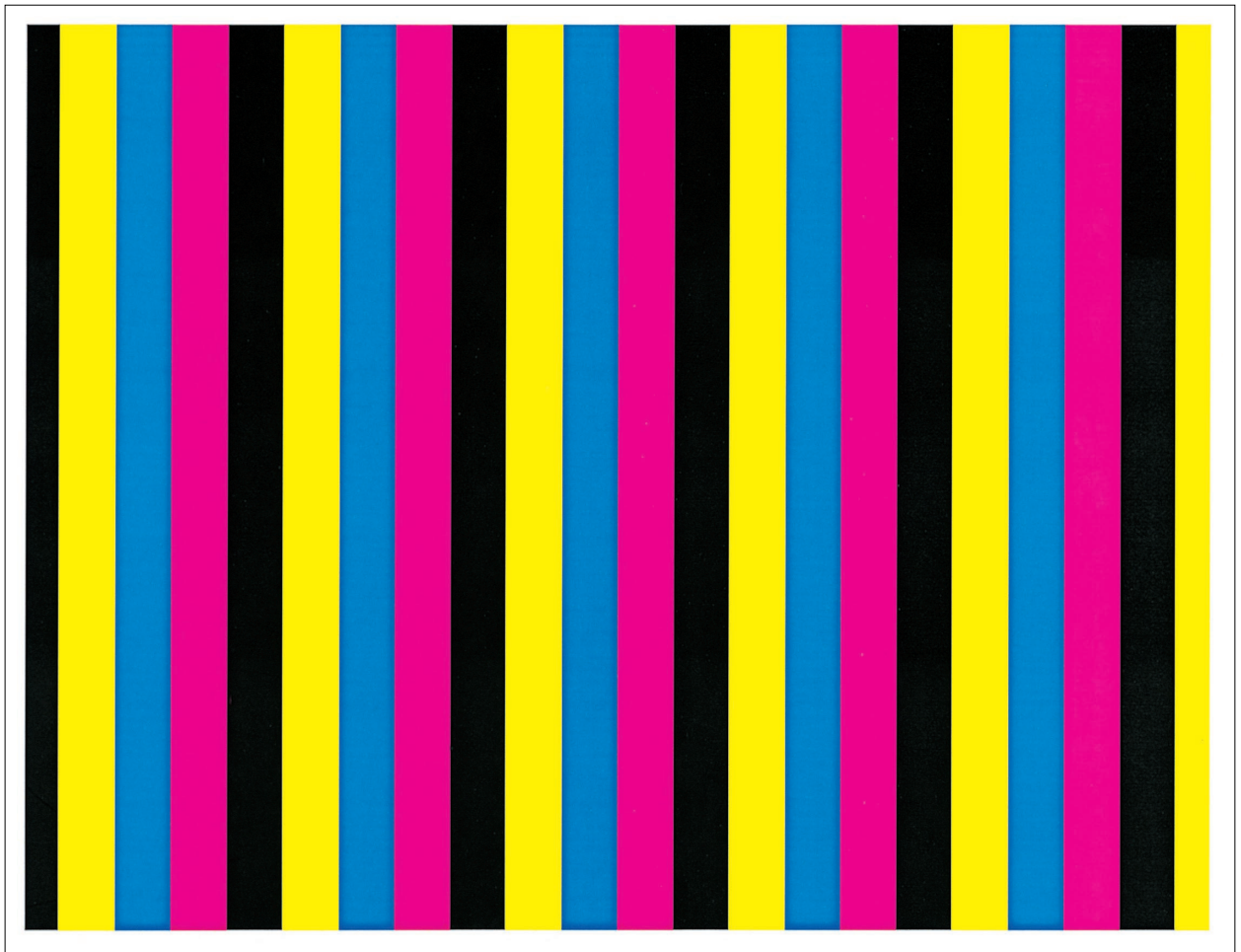

Figure 10-704

5. Controller Test Chart

Use the controller test chart to check the Controller board.

Note:

- Cassette 1 is used as the source of paper.
- The page consists of a single sheet.
- The page consists of a total 4 sheets.
- The chart contains various objects for checks.

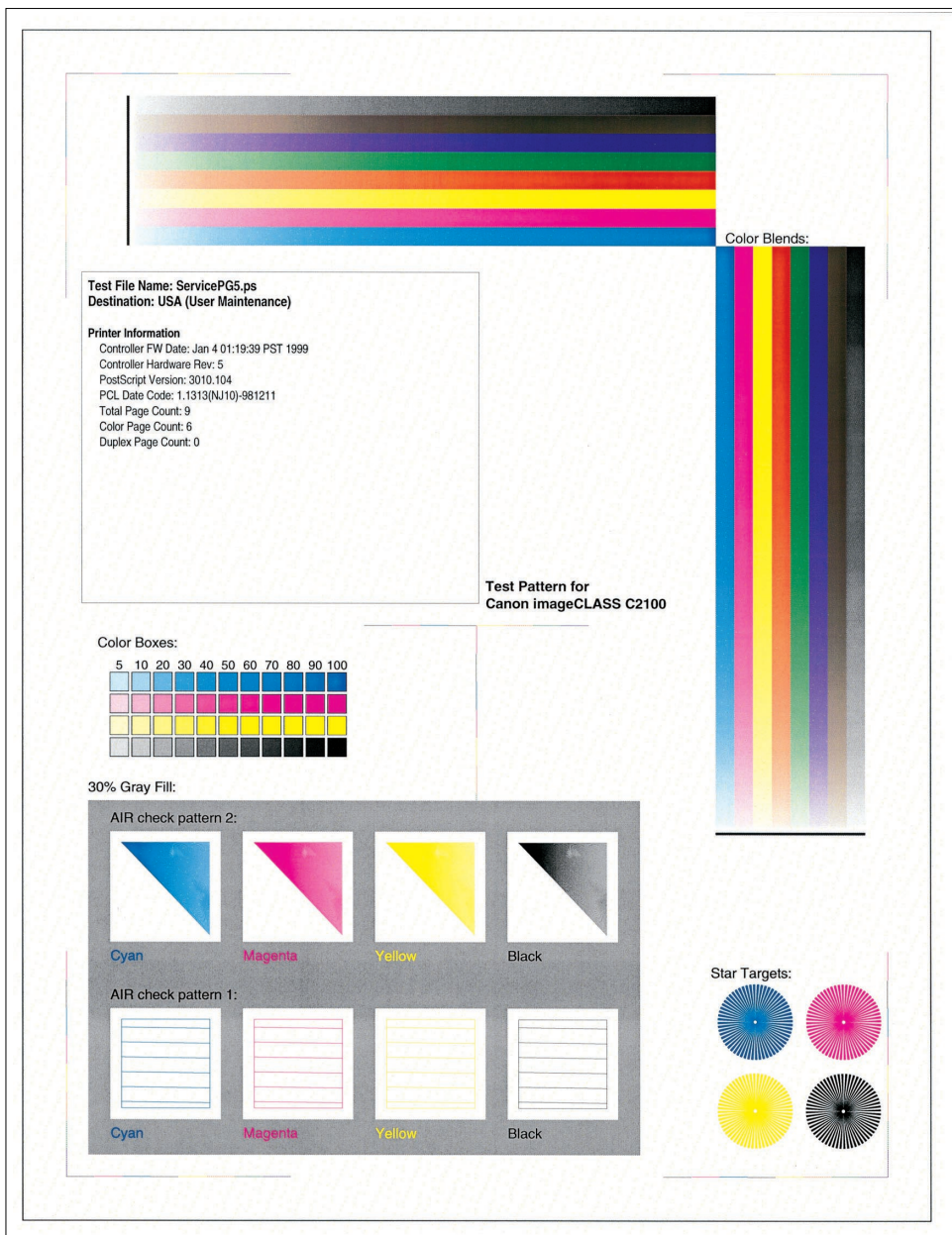

Figure 10-705

VIII. SELF DIAGNOSIS

The microprocessor on the DC controller PCB is equipped with a self diagnostic mechanism which checks the condition of the printer unit (in particular, condition of the sensors). The mechanism runs a check as needed and, upon detection of an error, will indicate an error code on the copier's control panel.

A. Printer unit

Code	Cause	Description
E000	<ul style="list-style-type: none"> The fixing assembly warm-up is faulty. 	<ul style="list-style-type: none"> When the time taken to reach the standby temperature from 20°C after the fixing heater has been turned on is longer than the reference time.
E001	<ul style="list-style-type: none"> The fixing assembly has overheated. 	<ul style="list-style-type: none"> The fixing temperature during standby or printing exceeds about 230°C.
E003	<ul style="list-style-type: none"> The fixing temperature is abnormally low. 	<ul style="list-style-type: none"> The fixing assembly temperature drops below 120°C after it has reached the target value.
E004	<ul style="list-style-type: none"> The upper/lower fixing heater has an open circuit. 	<ul style="list-style-type: none"> A check is made for an open circuit at the start of temperature control. The AC current expected in the fixing heater is absent.
E009	<ul style="list-style-type: none"> The fixing assembly type is wrong. 	<ul style="list-style-type: none"> The rated voltage of the machine's power supply and that of the fixing assembly do not match.
E010	<ul style="list-style-type: none"> The main motor start-up is faulty. 	<ul style="list-style-type: none"> The revolution of the main motor fails to reach a specific value.
E011	<ul style="list-style-type: none"> The main motor rotation is faulty. 	<ul style="list-style-type: none"> The revolution of the main motor deviates from a specific value.
E013	<ul style="list-style-type: none"> The waste toner case is full. 	<ul style="list-style-type: none"> A specific number of prints have been made after the waste toner case full warning has been issued (DISPLAY>SENSOR>W-TONER).
E019	<ul style="list-style-type: none"> The waste toner detection assembly operation is faulty. 	<ul style="list-style-type: none"> At time of power-on or while the drum motor is rotating during printing operation, the light-receiving cell of the waste toner sensor does not detect light for a specific time even when the waste toner case is not full.

Code	Cause	Description
E020	The density sensor is faulty.	During image stabilization correction control, the LED intensity signal (LEDCNT) is not generated or, if generated, is not received by the diode 1/2 normally.
E021	The developing rotary assembly is faulty.	<ul style="list-style-type: none"> • The developing rotation position sensor (PS3) does not detect the rotation position flag even when the developing rotary motor has rotated for a specific time. • The developing rotary position sensor (PS3) detects a faulty or wrong rotation position flag width.
E040	The holding plate lifter (multifeeder) is faulty.	During multifeeder pick-up, the holding plate position sensor (PS1302) does not detect the holding plate even when the DC controller PCB has generated the holding plate solenoid (SL4) ON signal.
E054	The duplexing roller of the duplexing unit drive mechanism is faulty. (The duplexing unit is an accessory.)	The duplexing feeding roller 1 home position sensor (PS23) does not detect the home position of the duplexing feeding roller 1 when paper is being fed to the duplexing unit.
E055	The horizontal registration guide mechanism of the duplexing unit is faulty. (The duplexing unit is an accessory.)	The duplexing driver PCB has detected that the horizontal registration guide has moved in excess of the maximum distance from when the home position has been detected.
E066	The temperature/humidity sensor is faulty.	During image stabilization control, the DC controller PCB cannot detect the temperature sensor signal (TMPSNS) or the humidity sensor signal (HUM-SNS).
E100	The laser of the scanner unit is faulty.	The DC controller PCB detects BDERR for 2.5 sec or more after the scanner motor has rotated at a specific speed.
E110	The laser scanner motor is faulty.	<ul style="list-style-type: none"> • The scanner motor fails to reach a specific revolution within 10 sec after it has started to rotate. • The BD PCB detects an error within 2.5 sec after the scanner motor has rotated at a specific revolution.
E196	The EEPROM on the DC controller PCB is faulty.	The EEPROM (IC212) on the DC controller PCB has an error.

Code	Cause	Description
E197	The internal communication has an error.	A machine internal communication error occurs more than once. Or, the reception interruption on the DC controller side does not occur for a specific time for internal communication.
E198	The IC on the DC controller PCB has an error.	The IC on the DC controller PCB has an error.
E240	<ul style="list-style-type: none"> • The communication between the DC controller PCB and the reader controller PCB is faulty. • The communication between the DC controller PCB and the PS/PCL board or between the reader controller PCB and the PS/PCL board is faulty. 	<ul style="list-style-type: none"> • The DPPRDY signal is not sent for 0.25 sec or more from the reader controller to the DC controller PCB after the DC controller PCB is supplied with power. • The signals between the PS/PCL board and the DC controller PCB or between the PS/PCL board and the reader controller PCB cannot be exchanged for a specific time after the PS/PCL board is supplied with power.
E545 ^{*4}	The bin flapper 1 of the sorter-H1 is faulty.	The bin flapper solenoid sensor (PI12) does not detect solenoid operation even when the solenoid (SL3) is driven during initialization or face-down delivery. Or, the bin flapper sensor remains on even when the solenoid has stopped operation.
E546	The bin flapper 2 of the Sorter-H1 is faulty.	The bin flapper solenoid sensor (PI12) does not detect solenoid operation even when the solenoid (SL4) is driven during initialization or face-down delivery. Or, the bin flapper sensor remains on even when the solenoid has stopped operation.
E677 ^{*3}	The initial communication between the ACC controller PCB and an accessory has an error.	<ul style="list-style-type: none"> • The ACC controller PCB and the accessory fail to become ready for communication in 4 sec (possibly, a problem in the power supply). • An initial communication error with each accessory has occurred.
E678 ^{*3}	The communication between the ACC controller PCB and an accessory has been interrupted.	<ul style="list-style-type: none"> • The accessory is turned off in the middle of communication. • The cable of the accessory has been disconnected in the middle of communication.
E679 ^{*3}	The protocol used for communication between the ACC controller PCB and an accessory has an error.	The read/write/parity check of data is faulty, and communication fails to end within a specific time.

Code	Cause	Description
E805	The heat discharge fan 1 (FM1); used for the fixing assembly and area near the feeding assembly) is faulty.	The motor lock signal (FAN1LK) goes '1' for 1.5 sec or more while the fan is rotating.
E806	The heat discharge fan (FM2; used for the area around the intermediate transfer drum) is faulty.	The fan motor lock signal (FAN2LK) goes '1' for 1.5 sec or more while the fan is rotating.
E807	The heat discharge fan (FM3; used for the area around the scanner) is faulty.	The fan motor lock signal (FAN3LK) goes '1' for 1.5 sec or more while the fan is rotation.
E808	The fixing drive circuit/power unit is faulty.	The fixing heater safety circuit has detected a fault in the upper/lower fixing heater.
E810	The drum cartridge is absent.	The drum cartridge detecting switch does not turn on at power-on or when the cover is opened/closed.
E812	The intermediate transfer drum (ITD) is absent.	The intermediate transfer drum (ITD) home position is not detected within a specific time (about 10 sec).
E813	The fixing assembly is absent.	Both the upper fixing roller temperature detection signal (FXTHU) and the lower fixing roller temperature detection signal (FXTHL) indicate -10°C or less.
E814	The photosensitive drum in the drum cartridge has reached the end of its life.	A specific number of copies have been counted after issuing the photosensitive drum end of life warning.
E903 ^{*5}	The paper deck lifter is faulty.	<ul style="list-style-type: none"> • An error has been detected of the paper deck lifter motor. • The lifter upward movement takes longer than a specific time. • The paper level change time is in excess of a specific value while the lifter is moving up.

Note:

For troubleshooting faults related to the printer unit, see III. "Troubleshooting Malfunctions" in Chapter 10; however, for disassembly/assembly, see the Reader Unit Service Manual.

*1: See the Copy Data Controller Service Manual.

*2: See the Feeder Service Manual.

*3: See the ACC Controller Service Manual.

*4: See the 7-Bin Sorter Service Manual.

*5: See the Paper Deck Service Manual.

Note:

1. The EEPROM on the DC controller PCB contains various data (e.g., registration adjustment values) of each machine model. If you are replacing the DC controller PCB, be sure to transfer the data to the new DC controller PCB as instructed under I.A.1. "Replacing the DC Controller PCB" in Chapter 10.
2. Upon detection of E000, E001, E003, E004, E009, or E808, the printer unit issues a service person call and then turns itself off in 20 sec.
3. In the case of a fault associated with E001 or E003, the data may be stored in the error memory capacitor (C259) on the DC controller PCB. After removing the cause, be sure to discharge the capacitor. (Short JP201 on the DC controller PCB to discharge C259; see p. 10-80.)
4. The machine's laser/scanner assembly and intermediate transfer drum unit are not designed for adjustment in the field. Do not disassemble them. (However, the secondary pre-transfer charging assembly inside the intermediate transfer drum may be replaced.)
5. The control panel of the printer unit indicates error codes associated with the printer unit; if the reader unit is installed, error codes related to the reader unit will be dealt with by indicating "SERVICE CALL CHECK READER."
 - The control panel of the reader unit indicates error codes associated with the reader unit. Check the code, if any, and work according to the instructions in the Reader Unit Service Manual.

APPENDIX

A.	GENERAL TIMING CHART.....A-1	D.	SPECIAL TOOLS.....A-17
B.	SIGNALS AND ABBREVIATIONS.....A-7	E.	SOLVENTS AND OILS.....A-18
C.	GENERAL CIRCUIT DIAGRAM.....A-15		

A. GENERAL TIMING CHART

• Timing Chart during WAIT (1/2)

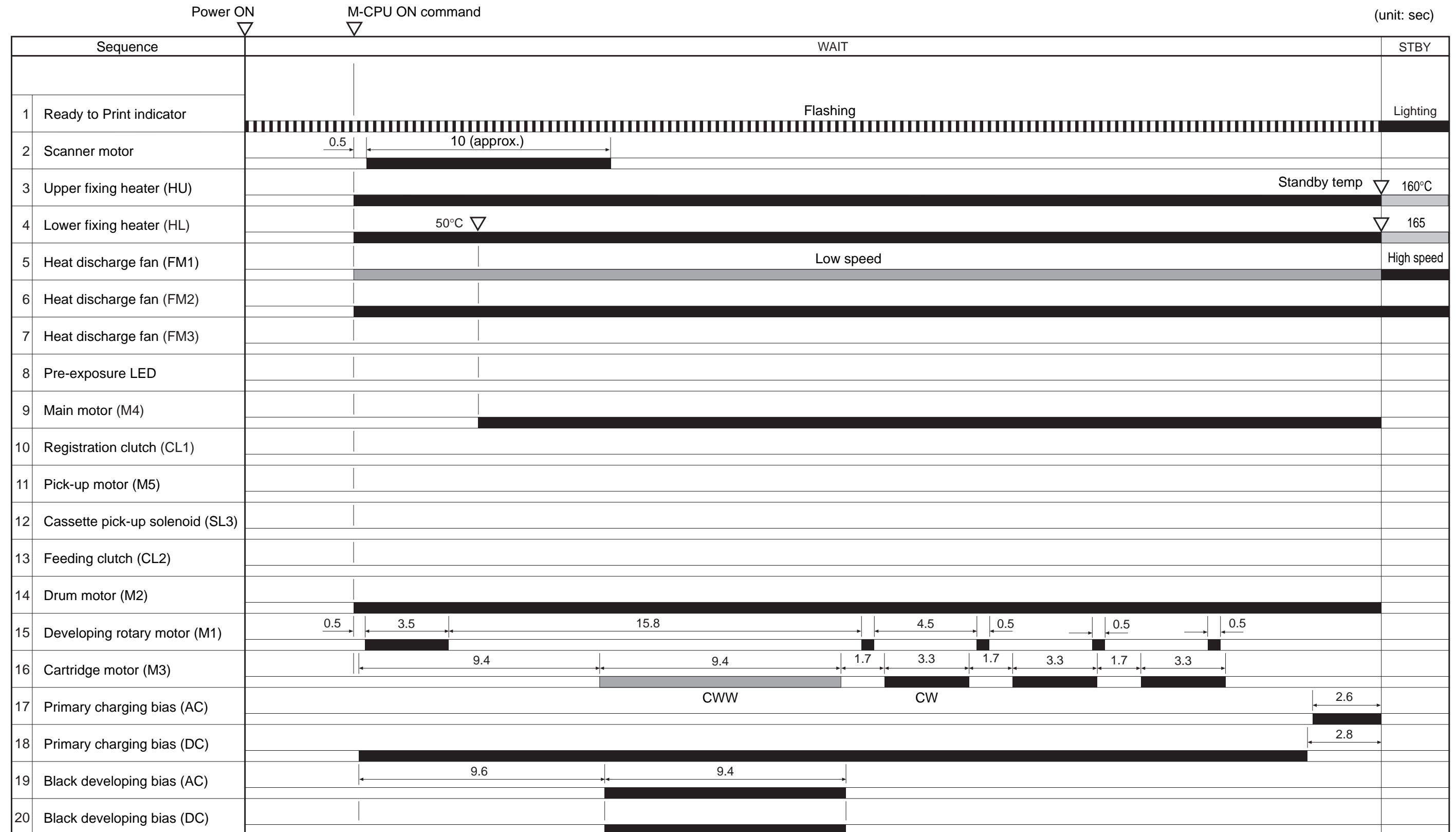

• Timing Chart during WAIT (2/2)

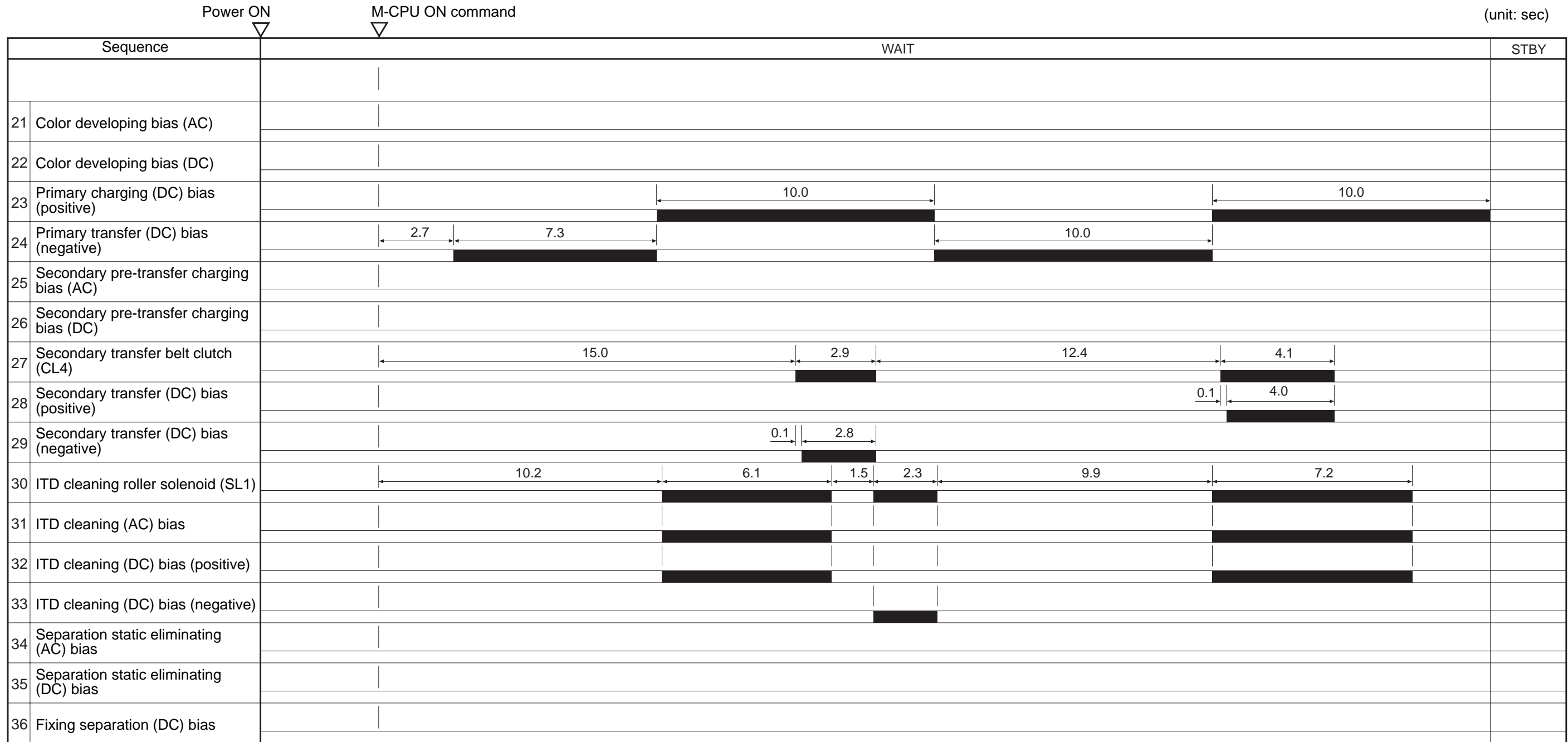

• Timing Chart 1 during PRINT (1/2)

A3,
Full-color,
1 Page,
Plain Paper

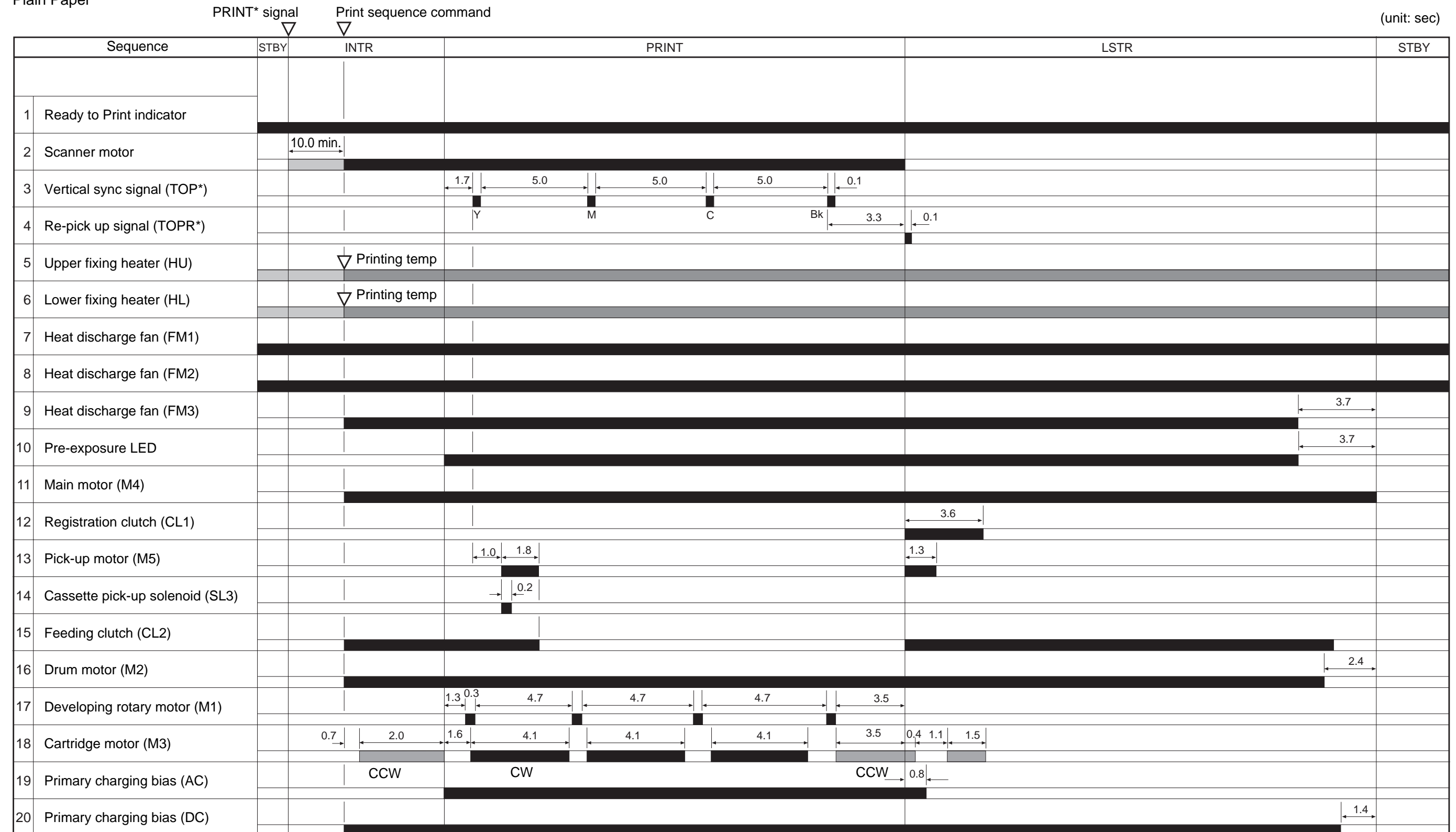

• Timing Chart 1 during PRINT (2/2)

A3,
Full-color,
1 Page,
Plain Paper

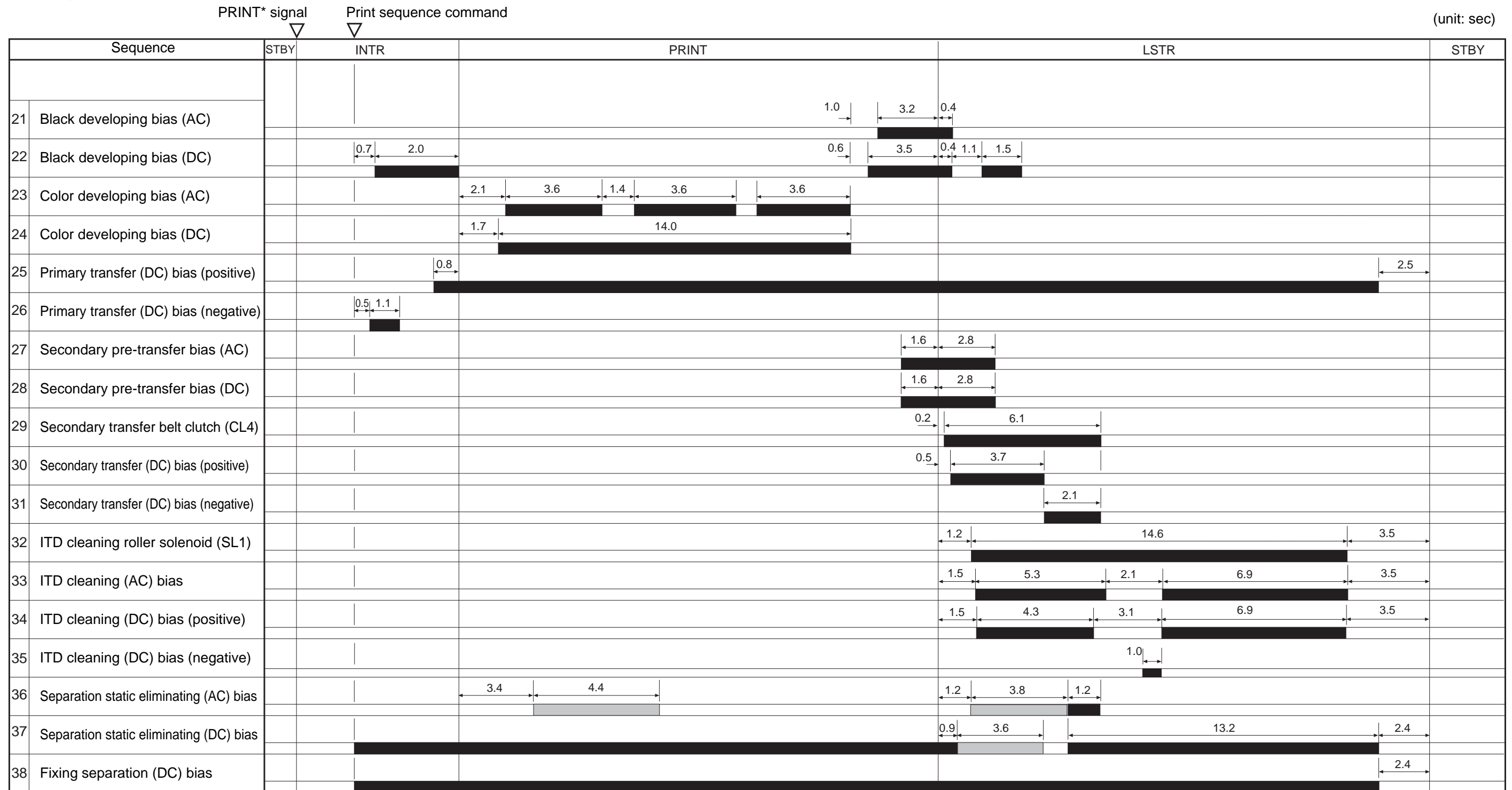

■ :turns on/off according to environment/paper type.

• Timing Chart 2 during PRINT (1/2)

A4, Horizontal,
Full-color,
2 Pages,
Plain Paper

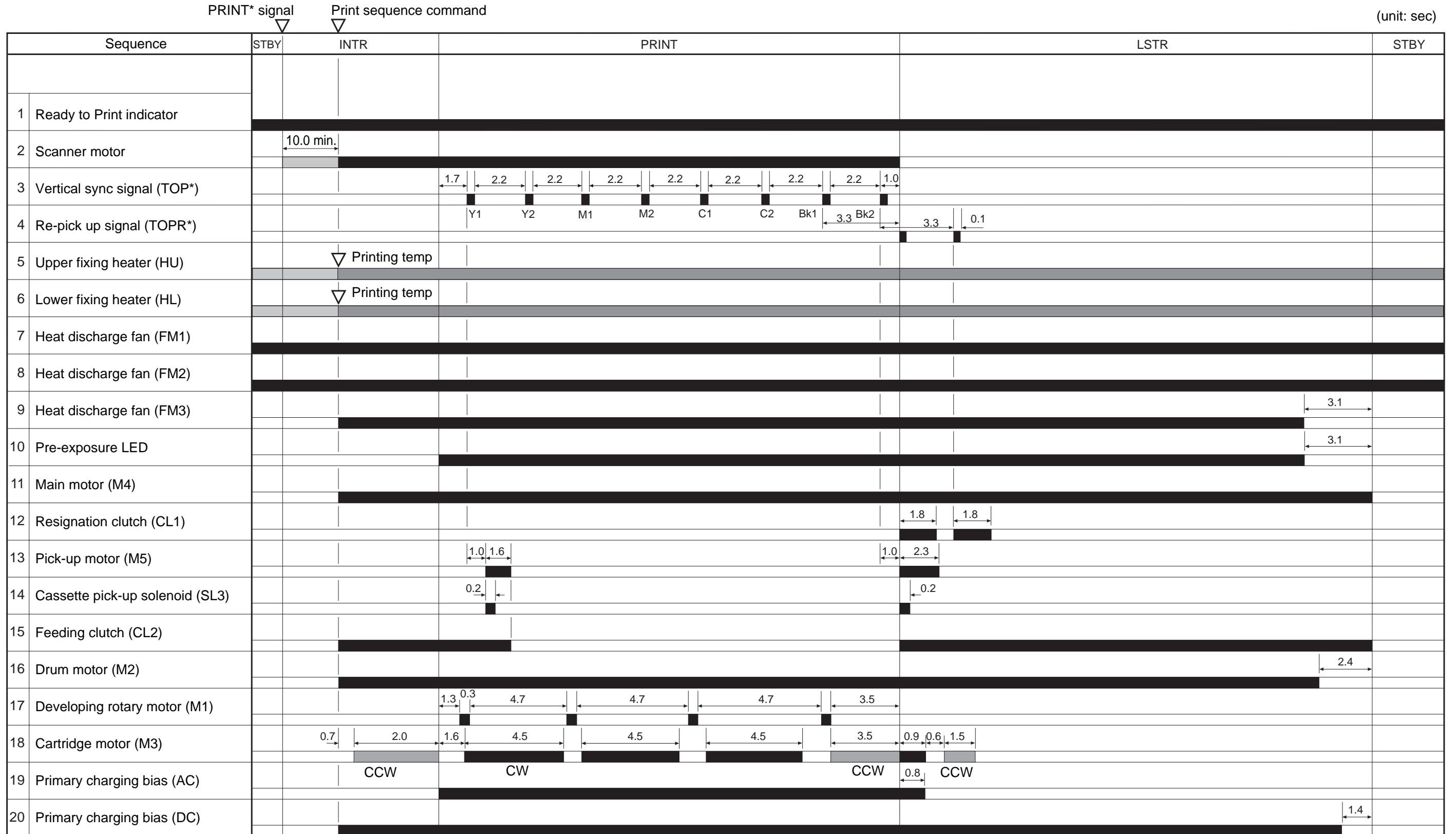

• Timing Chart 2 during PRINT (2/2)

A4, Horizontal,
Full-color,
2 Pages,
Plain Paper

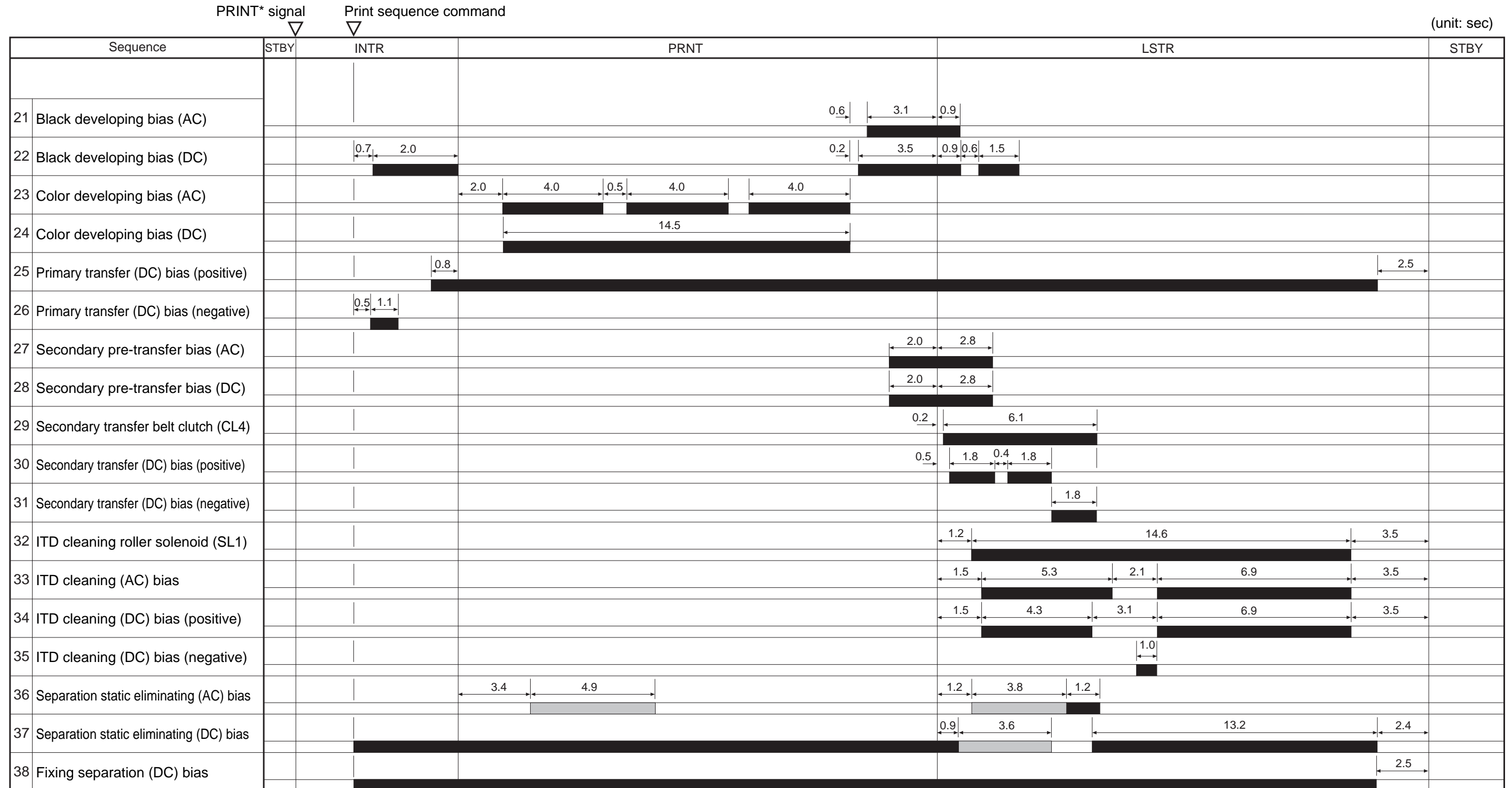

■ :turns on/off according to environment/paper type.

B. SIGNALS AND ABBREVIATIONS

1. Inputs to and Outputs from the DC Controller PCB

Connector	Pin	Abbreviation	Name
J202	A20	LSYNC*	horizontal sync signal
	A21	RDY*	ready signal
	A22	CPRDY*	controller power ready signal
	A23	SBSY*	status busy signal
	A24	CBSY*	command busy signal
	A25	SDM*	data mode setting signal
	A26	SPCHG*	reserved
	A27	PRNT*	print signal
	A28	FP0*	control panel signal 0
A31	FP5*	control panel signal 5	
	B1	VCLK	video clock signal
	B3	VDOE*	image enable signal
	B4	VDO0*	video signal
	B5	VDO1*	video signal
	B6	VDO2*	video signal
	B7	VDO3*	video signal
	B8	VDO4*	video signal
	B9	VDO5*	video signal
	B10	VDO6*	video signal
	B11	VDO7*	video signal
	B19	CCLK*	controller clock signal
	B20	TOPR*	registration drive signal
	B21	PPRDY*	printer power ready signal
	B22	TOP*	vertical sync signal
	B23	CCRT*	status change signal
	B24	STS*	status signal
	B25	CMD*	command signal
	B26	PFED*	paper feed signal
	B27	PDLV*	paper discharge signal
	B28	FP1*	control panel signal 1
B29	FP2*	control panel signal 2	
B30	FP3*	control panel signal 3	
B31	FP4*	control panel signal 4	
J203	A3	TR2DC	secondary transfer DC (positive) bias drive signal
	A4	RVTR2DC	secondary transfer DC (negative) bias drive signal
	A5	25KHz	high-voltage drive frequency output signal 3
	A6	50KHzB	high-voltage drive frequency output signal 2

Connector	Pin	Abbreviation	Name
J203	A7	TR2PWM	secondary transfer bias control signal
	A8	TR1PWM	primary charging transfer bias control signal
	A9	LSYNC*	ITD cleaning bias control signal
	B3	FIXDC	fixing separation DC bias drive signal
	B4	TR1DC	primary transfer DC (positive) bias drive signal
	B5	RVTR1DC	primary transfer DC (negative) bias drive signal
	B6	CLNDC	ITD cleaning DC (positive) bias drive signal
	B7	RVCLNDC	ITD cleaning DC (negative) bias drive signal
	B8	CLNAC	ITD cleaning AC bias drive signal
	B9	CORDC	secondary pre-transfer charging DC bias drive signal
	B10	CORAC	secondary pre-transfer charging AC bias drive signal
J204	2	IOTR*	IOT status signal
	4	IOTT*	IOT command signal
	5	TSEL4*	for factory adjustment
	6	TSEL3*	for factory adjustment
	7	TSEL2*	for factor adjustment
	8	TSEL1*	for factory adjustment
J205	1	PD	laser emission main motor signal
	3	LENB*	image enable signal
	5	BSAMPLE	APC sampling timing signal 1
	6	BSAMPLE*	APC sampling timing signal 2
	8	DBATA	PWM video data signal 1
	9	DBATA*	PWm video data signal 2
J206	1	TMPSNS	machine internal temperature detection signal
	3	HUMSNS	machine internal humidity detection signal
	5	+24UH	
	7	DNS	toner density detection signal
	8	DENREF	received light feedback signal
	9	LEDCNT	LED emission setting signal
J207	1	FUSLD*	face-up solenoid drive signal
	5	DEVHP	developing rotary position detection signal
	6	RLOCKS	cartridge releasing lever detection signal
	12	FXOUTS	fixing delivery detection signal
J208	3	MPDFS*	multifeeder tray last paper detection signal
	5	MPTWID	multifeeder ray paper width detection signal
J209	1	MDI1	cartridge memory data input signal
	2	MDO1	cartridge memory date output signal
	3	MSK1	cartridge memory serial clock signal
	4	MSC1	cartridge memory selection signal
	5	MPWR	cartridge memory power supply signal
	6	OPCSNS	drum cartridge detection signal

Connector	Pin	Abbreviation	Name
J210	1	FEDPHA*	pick-up motor drive signal
	2	FEDPHA	pick-up motor drive signal
	3	FEDPHB*	pick- motor drive signal
	4	FEDPHB	pick-up motor drive signal
	5	UDECKS*	cassette paper absent detection signal
	6	UDECKC*	cassette 1 detection signal
	7	FEDCLD*	feeding clutch drive signal
	8	FFEDS*	pick-up assembly paper detection signal
	9	PUPSLD*	cassette pick-up solenoid drive signal
	10	LDECKC*	cassette 2 detection signal
	11	LDECKS*	cassette 2 paper absent detection signal
	12	LPVS2*	cassette 2 paper level detection signal 2
	13	LPVS1*	cassette 2 paper level detection signal 1
	14	UPVS2*	cassette 1 paper level detection signal 2
	15	UPVS1*	cassette 1 paper level detection signal 1
	16	RDOORS*	pick-up cassette cover detection signal
J211	2	BD*	horizontal sync signal
	5	SCMFG	scanner motor speed signal
	7	SCND	scanner motor drive signal
J212	1	STRCLD*	secondary transfer belt clutch drive signal
	3	REGCLD*	registration clutch drive signal
	7	SEPS*	separation detection signal
	10	REGS*	registration paper detection signal
J213	4	MPTCLD*	multifeeder pick-up clutch drive signal
	5	MPTSLD*	holding plate solenoid drive signal
	6	MPTLS*	holding plate position detection signal
	7	MPTPS*	multifeeder tray paper detection signal
J214	3	OHPSNS1*	transparency detection signal 1
	6	OHPSNS2*	transparency detection signal 2
J215	3	UCEDFS	cassette 1 last paper detection signal
J216	2	FXSTS	fixing heater status detection signals
	3	FXSTS	fixing heater status detection signal
	4	FXLONS	lower fixing heater anti-rush current PCB drive signal
	5	FXLON	lower fixing heater drive signal
	6	FXUONS	upper fixing heater anti-rush current PCB drive signal
	7	FXUON	upper fixing heater drive signal
	8	FXENB	temperature enable signal
	9	FXRON	relay drive signal
	11	FXTHL	lower fixing roller temperature detection signal
	12	FXTHU	upper fixing roll temperature detection signal

Connector	Pin	Abbreviation	Name
J217	3	ACTYP	power supply type detection signals
	4	POFF	power-off detection signal
	5	PCONT	power-off control signal
J218	2	LSIZE4	cassette 2 size detection signal
	3	LSIZE3	cassette 2 size detection signal
	4	LSIZE2	cassette 2 size detection signal
	5	LSIZE1	cassette 2 size detection signal
	7	USIZE4	cassette 1 size detection signal
	8	USIZE3	cassette 1 size detection signal
	9	USIZE2	cassette 1 size detection signal
J219	10	USIZE1	cassette 1 size detection signal
	1	MSPED1	main motor speed switch signal 1
	2	MSPED2	main motor speed switch signal 2
	3	MRDY*	main motor ready signal
J220	4	MON*	main motor drive signal
	A1	FAN1LK*	fan motor 1 lock detection signal
	A2	FAN2LK*	fan motor 2 lock detection signal
	A3	FDFULL	face-down tray full detection signal
	A4	FMCO PN*	left cover detection signal
	A6	RLSROT	developing rotary stopper releasing signal
	A7	DEVICH1	developing rotary motor current switch signal 1
	A8	DEVPHB	developing rotary motor drive signal
	A9	DEVPHA	developing rotary motor drive signal
	B1	DEVPHA*	developing rotary motor drive signal
	B2	DEVPHB*	developing rotary motor drive signal
	B3	DEVICH2	developing rotary motor current switch signal 2
	B4	STPROT	developing rotary stopper signal
	B6	FDOUT*	face-down tray delivery detection signal
	B8	FAN2ON*	fan motor 2 drive signal
	B9	FAN1ON*	fan motor 1 drive signal
J221	1	CTNLED	color toner detection LED drive signal
	4	CTNSNS	color toner level detection signal 1
	5	WTNLED	waste toner detection LED drive signal
	7	WTNFUL	waste toner detection signal
J222	1	FXTHU	upper fixing roller temperature detection signal (to DC power supply safety circuit 1)
	3	FXTHL	lower fixing roller temperature detection signal (to DC power supply safety circuit 1)
	5	FXTYP	fixing assembly type setting signal

Connector	Pin	Abbreviation	Name	
J223	3	DUPIDS*	duplexing unit detection signal	
	4	DUPSTS*	duplexing unit status signal	
	5	DUPCMD*	duplexing unit command signal	
	6	DUPCLK	duplexing unit clock signal	
J224	3	DRMPHA	drum motor drive signal	
	4	DRMPHA*	drum motor drive signal	
	5	DRMPHB	drum motor drive signal	
	6	DRMPHB*	drum motor drive signal	
J225	2	FP5*	front panel signal 5	
	3	FP4*	front panel signal 4	
	4	FP3*	front panel signal 3	
	5	FP2*	front panel signal 2	
	6	FP1*	front panel signal 1	
	7	FP0*	front panel signal 0	
	J226	A1	BTNSNS	black toner level detection signal
A2		BDEVAC	black developing AC bias drive signal	
A3		BDEVDC	black developing DC bias drive signal	
A4		CDEVAC	color developing AC bias drive signal	
A5		CEDVDC	color developing DC bias drive signal	
A8		SLVICH	toner cartridge motor current switch signal	
A9		SLVPHA*	toner cartridge motor dive signal	
A10		SLVPHA	toner cartridge motor drive signal	
A11		CHGAC	primary charging AC bias drive signal	
A12		CHGDC	primary charging Dc bias drive signal	
		B1	FCHG	high voltage drive frequency output signal 1
		B2	CHGPWM	primary charging bias control signal
	B3	SLVPHB	toner cartridge motor drive signal	
	B4	SLVPHB*	toner cartridge motor dive signal	
	B5	50KHZB	high-voltage drive frequency output signal 2	
	B6	BDEVPWM	black developing bias control signal	
	B7	CDEVPWM	color developing bias control signal	
	B8	25KHz	high-voltage delivery output signal 3	
	B9	50KHzA	high-voltage delivery output signal 4	
	B10	125KHz	high-voltage delivery output signal 5	
	B11	FCOLOR	high-voltage delivery output signal 6	
	B12	FBK	high-voltage delivery output signal 7	

Connector	Pin	Abbreviation	Name
J227	A1	CCRGSNS	color cartridge detection signal
	A2	FAN3LK*	fan motor 3 lock detection signal
	A3	DSW1	delivery cover/front cover detection signal
	A4	DSW2	right cover detection signal
	A5	DSW3	black toner cartridge detection signal
	A6	CLNRON	ITD cleaning roller clutch drive signal
	B6	PSAVE*	
	B7	EXSW*	turret button switch signal
	B8	DSW5	drum cartridge switch signal
	B9	DSW4	toner cartridge cover switch signal
	B10	FAN3ON*	fan motor 3 drive signal
	B11	CCRGLED	color cartridge LED drive signal

2. Inputs to and Outputs of the Duplexing Driver PCB

Connector	Pin	Abbreviation	Name
J2001	3	DUPIDS*	duplexing unit detection signal
	4	DUPSTS*	duplexing unit status signal
	5	DUPCMD	duplexing unit command signal
	6	DUPCLK*	status clock signal
J2002	1	DUPSLD*	duplexing flapper solenoid drive signal
J2003	1	DUPCLD*	duplexing feeding clutch drive signal
J2004	1	SWBAD	duplexing motor control signal
	2	SWBAND	duplexing motor control signal
	3	SWBBD	duplexing motor control signal
	4	SWBBND	duplexing motor control signal
J2005	1	HRGCOMA	horizontal registration motor control signal
	2	HRGCOMB	horizontal registration motor control signal
	3	HRGAD	horizontal registration motor control signal
	4	HRGAND	horizontal registration motor control signal
	5	HRGBD	horizontal registration motor control signal
	6	HRGBND	horizontal registration motor control signal
J2006	3	HREGS	horizontal registration guide home position detection signal
J2007	3	SWBKS*	reversal paper detection signal
	6	DRPS	duplexing feeding roller 1 home position detection signal
J2008	3	DUPPS*	duplexing unit paper detection signal
J2009	1	PRRESLD	reversing roller releasing solenoid drive signal

**C. GENERAL CIRCUIT DIAGRAM
PRINTER UNIT (1/2)**

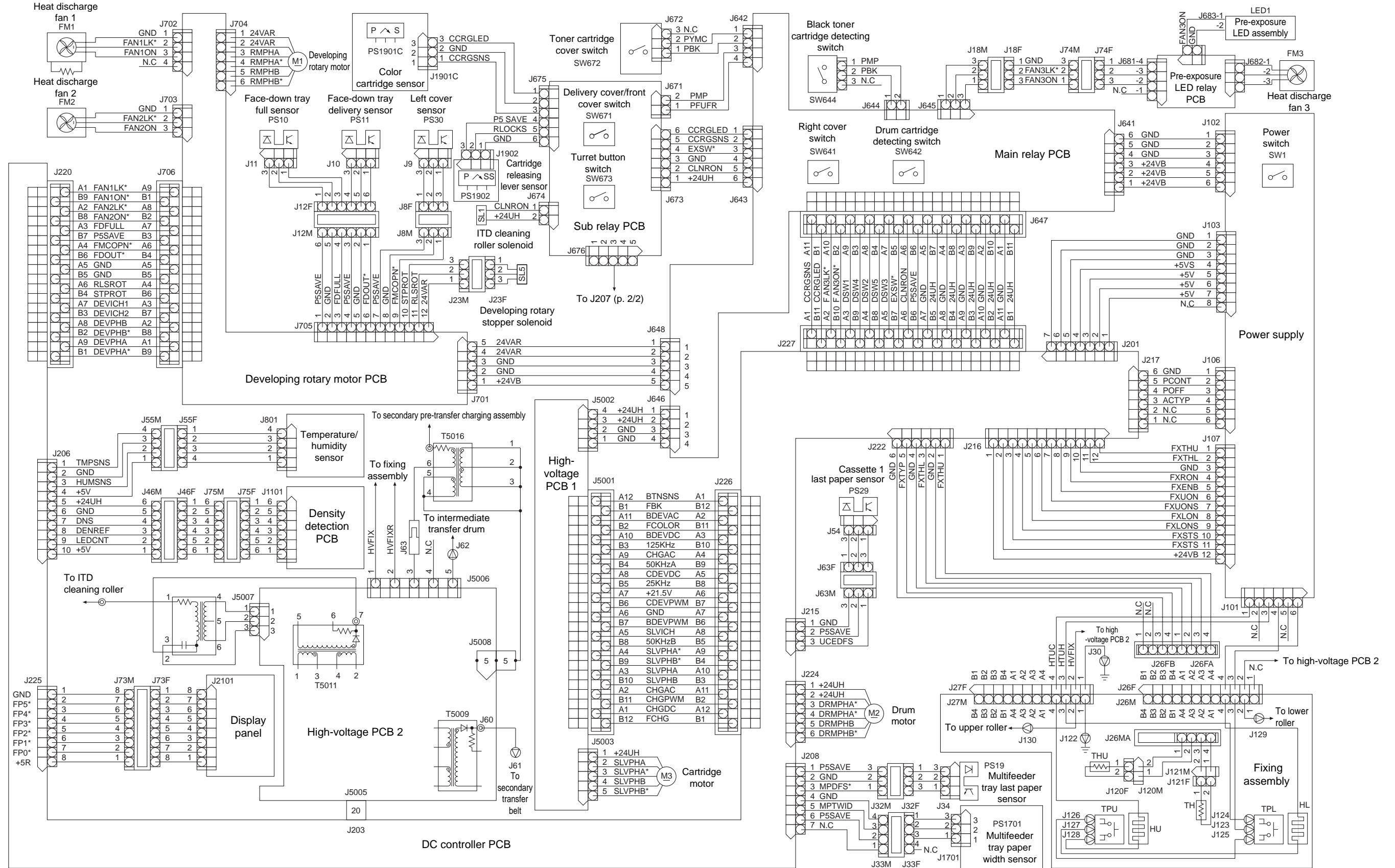

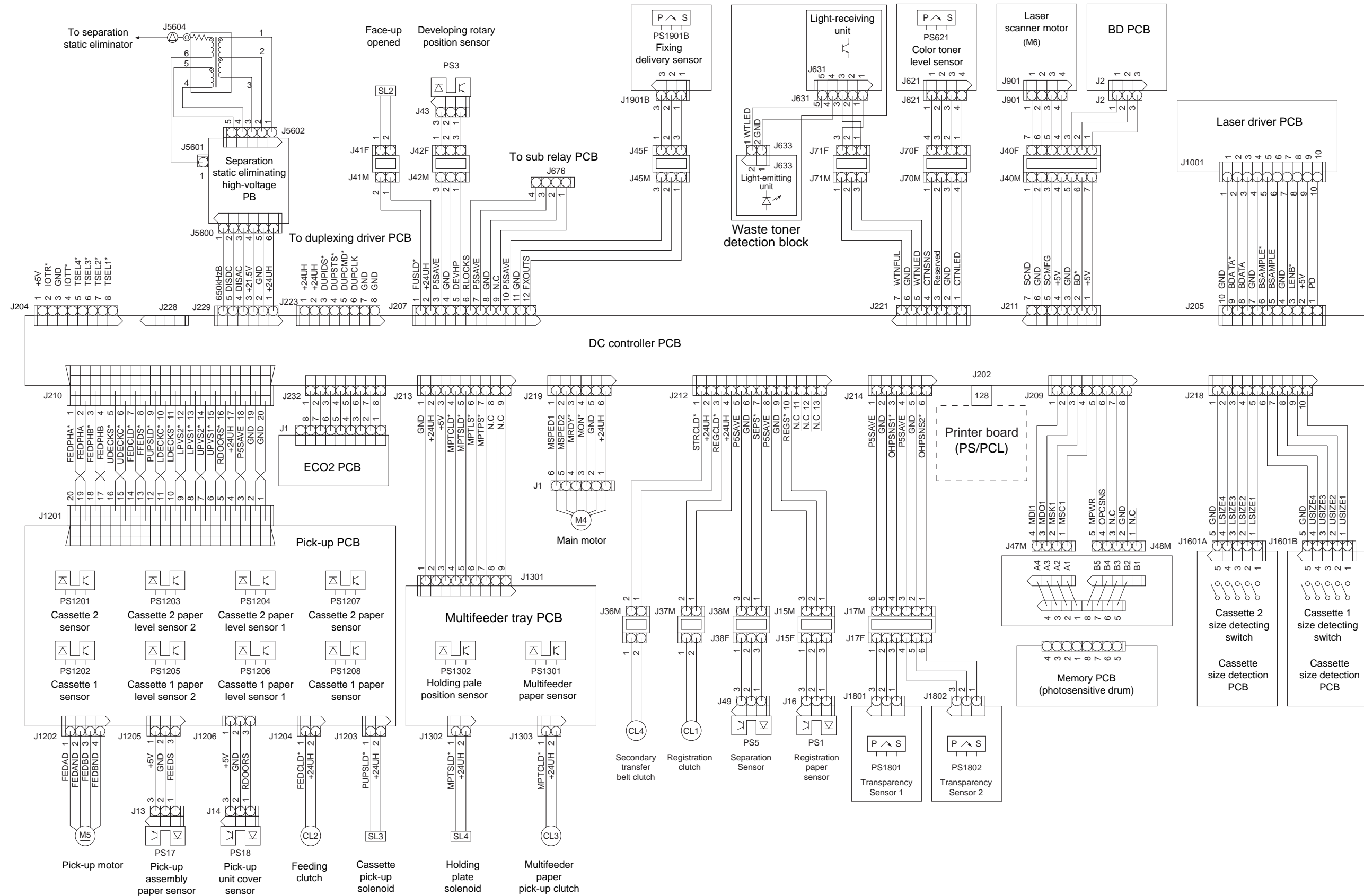

D. SPECIAL TOOLS

You will need the following special tools in addition to the standard tools set:

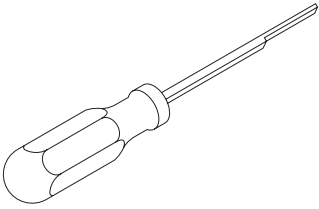
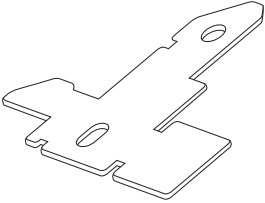
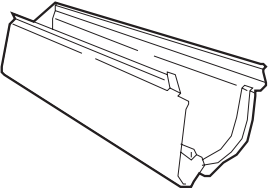
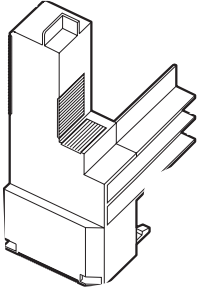
No.	Tool name	Tool No.	Shape	Rank*	Uses
1	Contact extracting tool	RY9-0099		A	For detaching the contact of the upper/lower heater of the fixing assembly.
2	Door switch	FY9-3036		A	For checking the operation of the printer unit during repairs; found as a set of four behind the front right cover. (See p. 5-22.)
3	Drum cover	MF4-0106		A	For protecting the drum cartridge against light.
4	Secondary transfer belt fixing member	RB1-9582		A	For securing the secondary transfer belt assembly in place when moving the printer unit.

*Rank.

- A: Each service person is expected to carry on.
- B: Each group of about five service persons is expected to carry one.
- C: Each workshop is expected to carry one.

E. SOLVENTS AND OILS

No.	Name	Uses	Composition	Remarks
1	Alcohol	Cleaning; e.g., glass, plastic (Note), and rubber parts and external covers.	Carbon hydrogen of fluorine family Alcohol Surface activating agent Water	CI, IPA (isopropyl alcohol)
2	Solvent	Cleaning; e.g., metal parts; removing oil or toner.	Carbon hydrogen of fluorine family Alcohol Carbon hydrogen of chlorine family	MEK
3	Lubricant	Lubricating; e.g., scanner rail.	Mineral oil (paraffin family)	CK-0451
4	Lubricant	Lubricating; e.g., between gear and shaft.	Mineral oil of petroleum family.	CK-8003
5	Lubricant	Lubricating; e.g., gears.	Special oil Special sold lubricating agent Lithium soap	HY9-0007
6	Lubricant	Lubricating; e.g., drive parts.	Silicone oil	CK-0551 (20 g)

Note:

Be sure to clean the external covers with a moist (however, well wrung) cloth.

Prepared by
Office Imaging Products Technical Support Department 3
Office Imaging Products Quality Assurance Center
CANON INC
Printed in Japan

REVISION 0 (FEB. 1999) (33130)

7-5-1, Hakusan, Torideshi, Ibaraki 302-8501 Japan

Canon



The publication is printed on
70% reprocessed paper.